

NOV MONO SOLVES SLUDGE TRANSFER PROBLEM FOR GERMAN WASTE WATER PLANT

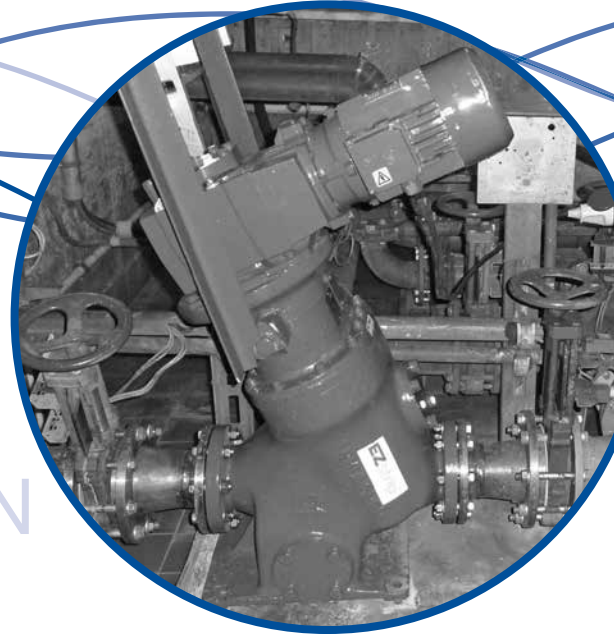

NOV Mono has helped solve an ongoing maintenance problem for a major German wastewater treatment plant with the installation of an EZstrip™ TR Muncher. The Mono Muncher™ has dramatically reduced the number of pipeline blockages occurring at the Käranlage Jagersfreude plant – the largest facility of its kind in the Saarbrücken area - and so helped minimise both downtime and maintenance costs.

The customer's previous macerator had been experiencing increasingly frequent blockages – often one each day - due to the 8-12% dried solids and fibre content of the raw sludge it was handling. The process of repeated de-ragging was both time consuming and expensive, so an alternative solution was sought.

The Mono EZstrip™ TR Muncher was designed specifically to provide efficient maceration of abrasive sludges in this type of application. The Muncher's layback cutter shafts are set at an angle to the incoming sludge flow, making it extremely effective in capturing and macerating solids held in the flow. For the Käranlage Jagersfreude plant this helped to increase protection for pumps and other equipment further along the process line by minimising wear and so reducing the needs for spares to be held. If a rejection cycle is necessary, the Muncher can drop the object into the built-in trap which is set below the cutter stacks to prevent damage occurring. The waste trap features a large-diameter access port which allows for easy removal of debris, cleaning and flushing.

The complete drive, gearbox and cutter assembly can be removed from the Muncher's casing, without

disturbing the pipework. "This makes any maintenance activities much quicker to complete and it also reduces the downtime and the associated costs," explains Jagersfreude plant Abwassermeister, Ewald Stresser. "The Mono Muncher handles around 30m³/h of raw sludge and has worked very efficiently since it was installed, but it is reassuring to know that if a blockage does occur we can remove it far more quickly and easily than we could previously."

The ETOS cutters in the Mono EZstrip™ TR Muncher provide effective maceration, as the cutter shafts operate at differential speeds to exert a tearing action on the solids. A cantilever shaft design eliminates the need for bottom bearings and seals which significantly reduces wearing components, while low cutter tip speeds reduce wear. A low power consumption rating further cuts the TR Muncher's operating costs.

Each Muncher is supplied with a programmable logic controller to protect against overload damage, and they can be supplied to comply with the ATEX Directive 94/9/EC.

Muncher Type:	CT203CBW9B2
Product:	Raw sludge
Capacity:	30m³/h
Drive:	2.2kW motor



NOV Mono
Martin Street, Audenshaw
Manchester, M34 5JA England
T. +44 (0)161 339 9000
E. info-mono@nov.com
www.mono-pumps.com

NOV Mono

One Company, Unlimited Solutions