

EZstrip™ Hose Pump

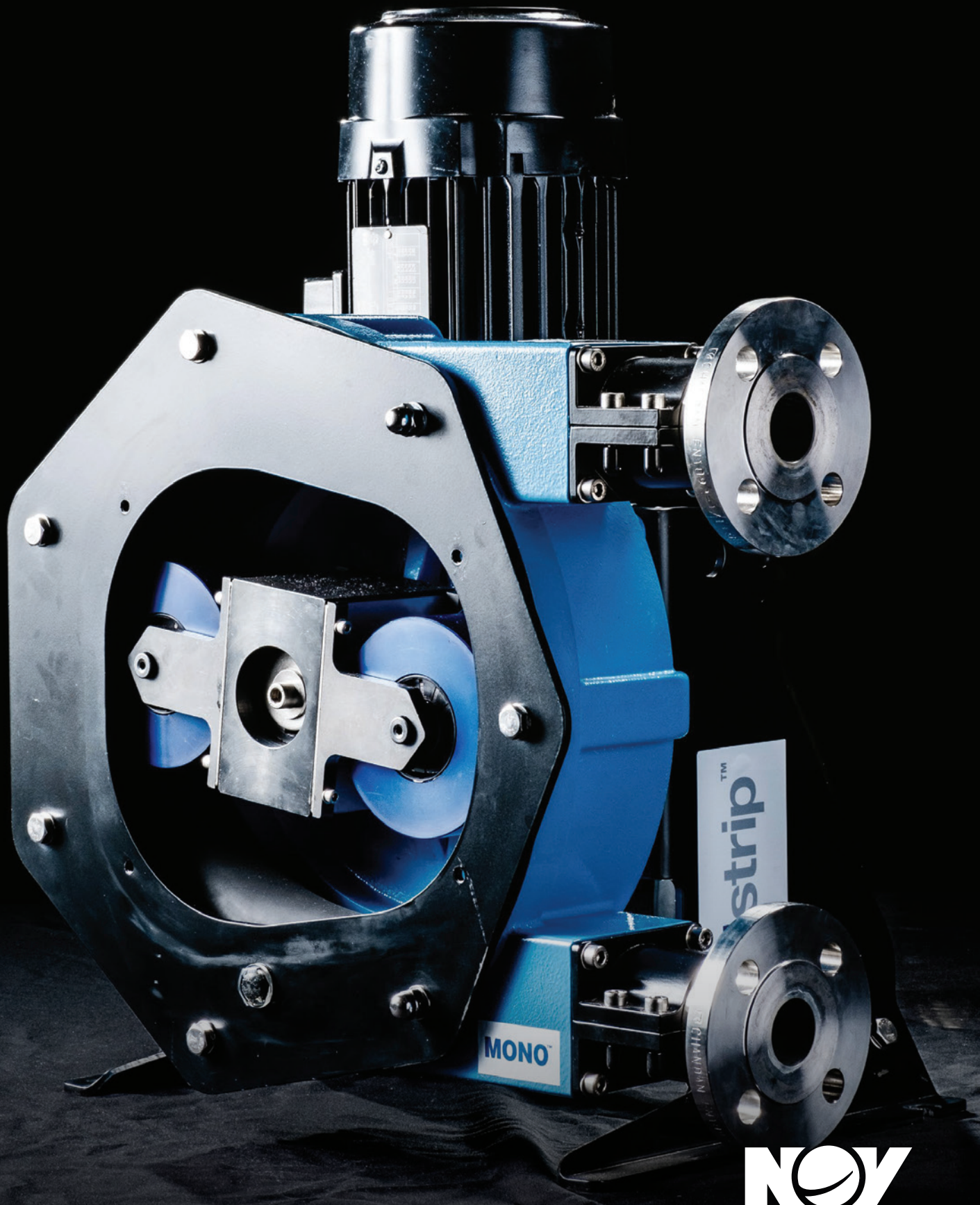

NOV



EZstrip™ Hose Pump

Heavy duty hose pumps with large rollers

Features and benefits of peristaltic technology:

- Maximum resistance to abrasion
- Unmatched suction capability
- Indefinite dry running
- No valves or mechanical seals
- Gentle and reversible pumping
- Full dosing control
- Industrial, corrosion resistant, and food versions
- Dosing accuracy of $\pm 1\%$

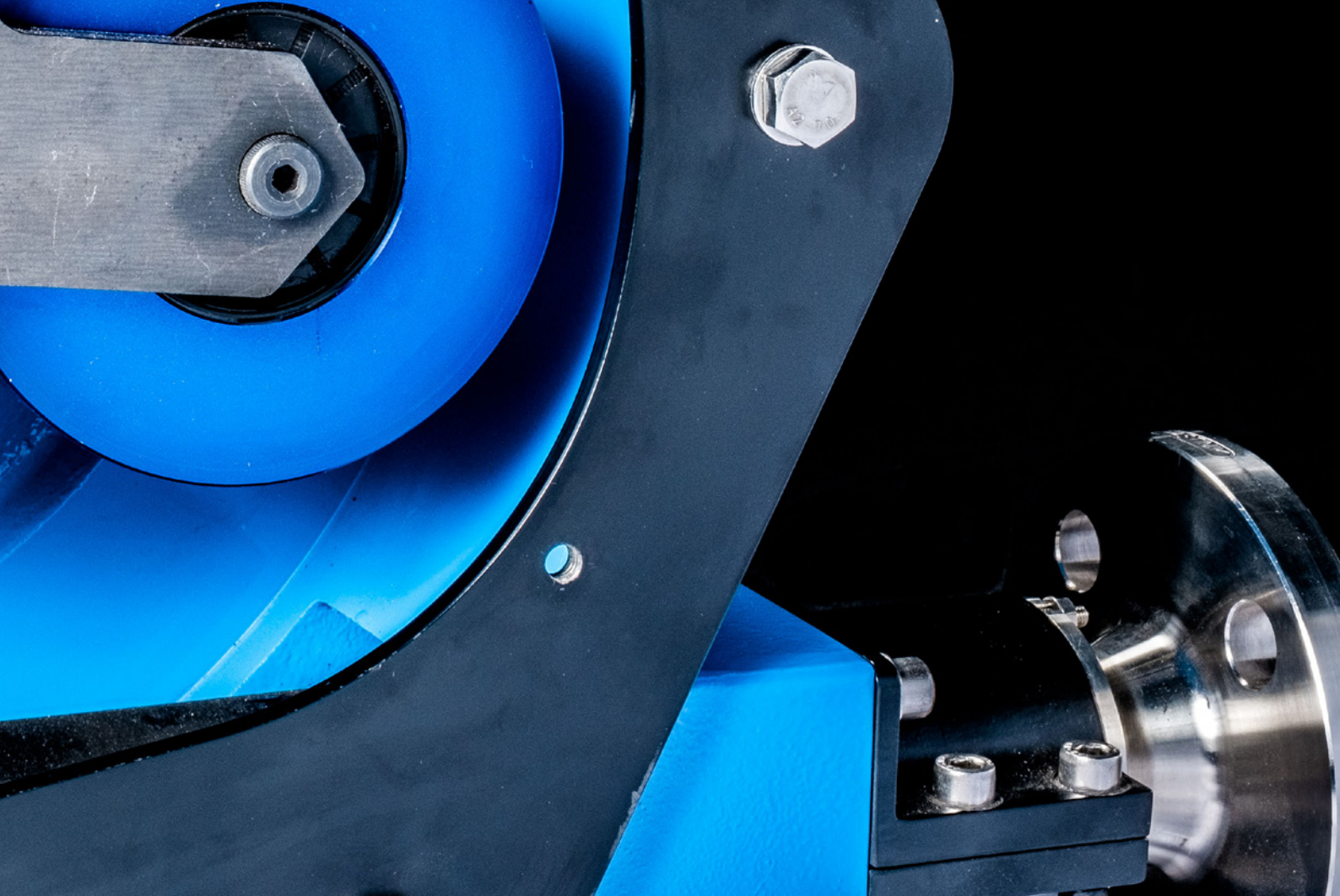

Advantages of NOV's EZstrip™ hose pumps compared with:

Hose pumps with shoe technology

Energy savings of up to 30%, ease of hose replacement, wide range of operation, and low starting torque.

Progressive cavity pumps

Allow dry running and have no mechanical seals. Simple adaptation to pumping of corrosive products.

Diaphragm dosing pumps

Easy to install, better suction, and better performance with solid and viscous products.

Air operated diaphragm pumps

Incomparable efficiency and absence of valves that make the passage of solids difficult.

EZstrip™ Hose Pump

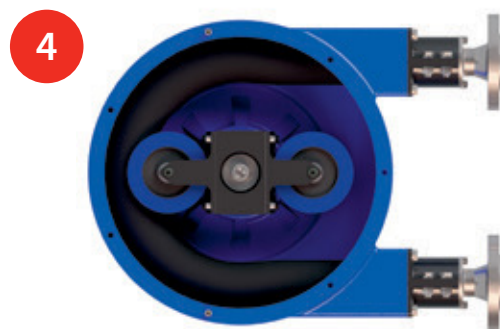
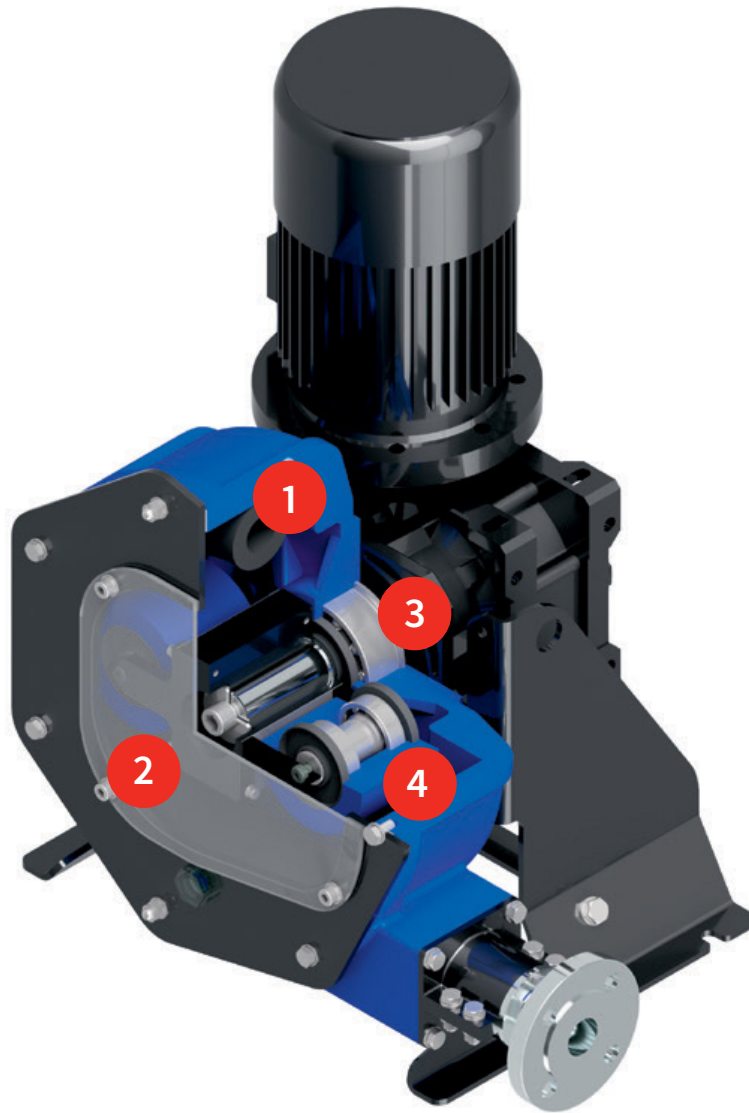

Latest technology peristaltic hose

1

High-quality hose with unique manufacturing process. Extruded inner layer, high-density textile reinforcement, and precision machined outer layer that ensures optimal compression and rapid installation thanks to control of the tolerance. Available materials compatible with all types of product and working conditions. Excellent performance against abrasion, temperature, and corrosion.

Saving on hose consumption and ease of installation downtime optimisation.

Ease of assembly, operation, and maintenance.

2

Fast and simple assembly, commissioning, and maintenance. Pump design with innovative assembly that facilitates hose replacement. Maintenance-free pump with lubricated-for-life system and low lubricant level. Minimal waste generated.

Saves on maintenance costs and ease of assembly. Reduces downtime.

Extremely heavy duty design for the most demanding applications up to 10 bar

3

Integrated oversized bearings to withstand the axial loads. Large metal rollers with oversized bearings. Secure and reliable connection system and very robust construction materials. Ideal pump for continuous work applications.

Unmatched pump life and excellent equipment performance under any operating conditions.

XXL roller technology

4

Excellent compression of the hose with no friction and unmatched efficiency. Low energy consumption and better hose life due to roller size. Ease of operation with a minimal starting torque and a very wide frequency range.

Major energy savings, higher number of hose working hours, and ease of operation.

Models ZH1235, ZH1285 and ZH1350

Ease of installation for accurate dosing

The design of models ZH1235, ZH1285, and ZH1350 achieves a small, heavy duty pump with XXL rollers that is unique to the market. The bearings installed between the rotor and the gear reducer fully absorb all the axial loads, which frees the reducer from fatigue and maximises its service life.

Thanks to the precision of all the compression components, due to the differentiated manufacturing process of the peristaltic hose, and quality of its materials, the models achieve unmatched durability.

The EZstrip™ Hose Pump models ZH1235, ZH1285, and ZH1350 cover a flow rate range between 5 and 1,000 l/h. These robust pumps with compact vertical design are ideal for the dosing applications for all types of abrasive, corrosive, viscous, or delicate products with discharge pressures of up to 10 bar.

The EZstrip™ Hose Pumps offer maximum flow rate control, process efficiency, and ease of installation and maintenance, solving applications including dosing of chemicals, additives, lime milk, activated carbon, and polymers.

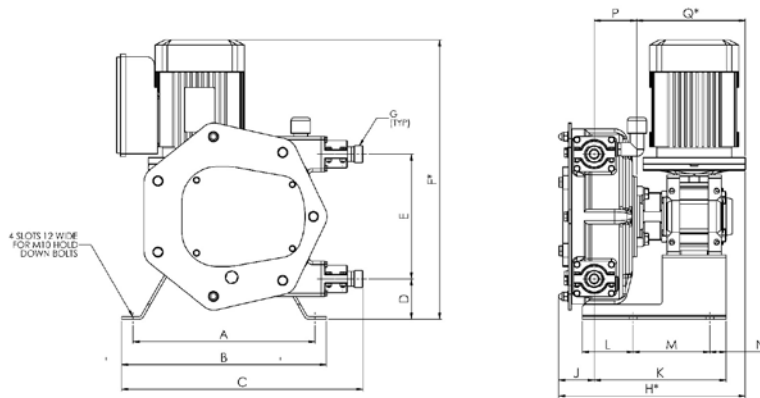

Model	A	B	C	D	E	F*	G	H*	J
ZH1235	235mm	265mm	305mm	62mm	116mm	367mm	3/8" BSP	242mm	49.5mm
	9.25"	10.43"	12.01"	2.44"	4.57"	14.45"	3/8" NPT	9.53"	1.95"
ZH1285	285mm	320mm	378mm	63mm	195mm	436mm	3/4" BSP	288mm	56mm
	11.22"	12.6"	14.88"	2.48"	7.68"	17.17"	3/4" NPT	11.34"	2.21"
ZH1350	350mm	380mm	449.5mm	70mm	224mm	488mm	1" BSP	360.5mm	62mm
	13.78"	14.96"	17.7"	2.76"	8.82"	19.22"	1" NPT	14.19"	2.44"

Model	K	L	M	N	P	Q*
ZH1235	163mm	54mm	80mm	33mm	56mm	137mm
	6.42"	2.13"	3.15"	1.3"	2.21"	5.39"
ZH1285	205.5mm	79.5mm	120mm	25.5mm	66.5mm	170mm
	8.09"	3.13"	4.72"	1"	2.62"	6.69"
ZH1350	258.5mm	78mm	120mm	72mm	86.5mm	212mm
	10.18"	3.07"	4.72"	2.84"	3.41"	8.35"

Standard configurations shown
 *Depending on the driver, dimensions could change.

Technical specifications	Model ZH1235
Max. flow (continuous)	205 l/h (0.9 GPM)
Capacity	0.043 l/rev (0.01 g/rev)
Max. discharge pressure	10 bar (145 PSI)
Max. temperature	80 °C (176°F)
Inner diameter	13 mm (0.51")
Hose material	NR, EPDM and NBR (food grade)
Connections	AISI-316, PP, PVDF (PTFE)

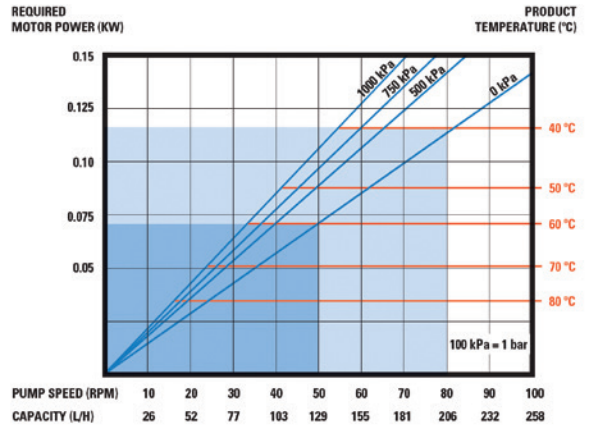

Technical specifications	Model ZH1285
Max. flow (continuous)	500 l/h (2.2 GPM)
Capacity	0.109 l/rev (0.03 g/rev)
Max. discharge pressure	10 bar (145 PSI)
Max. temperature	80 °C (176°F)
Inner diameter	16 mm (0.63")
Hose material	NR, EPDM and NBR (food grade)
Connections	AISI-316, PP, PVDF (PTFE)

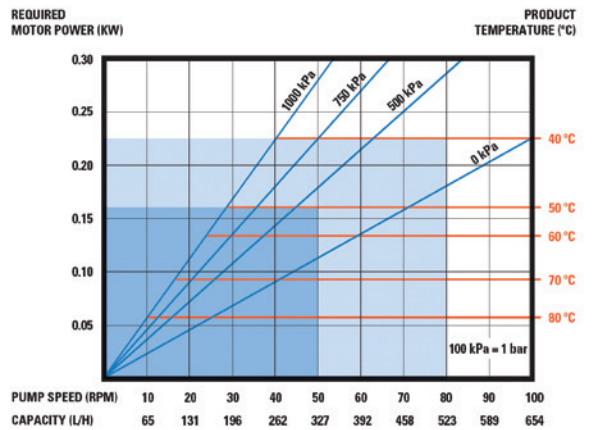

Technical specifications	Model ZH1350
Max. flow (continuous)	1100 l/h (4.84 GPM)
Capacity	0.227 l/rev (0.06 g/rev)
Max. discharge pressure	10 bar (145 PSI)
Max. temperature	80 °C (176°F)
Inner diameter	22 mm (0.87")
Hose material	NR, EPDM and NBR (food grade)
Connections	AISI-316, PP, PVDF (PTFE)

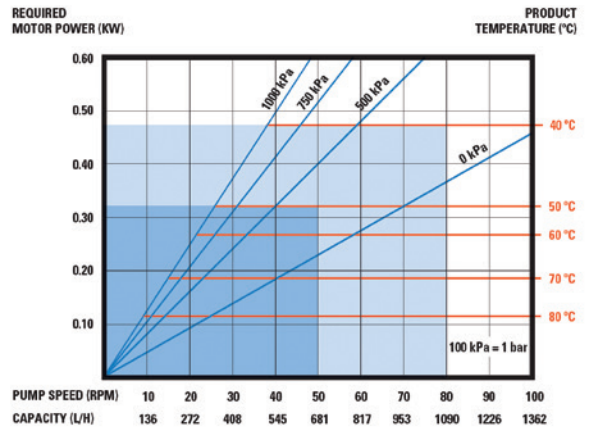

Models ZH1390, ZH1440

The most compact and heavy duty solution for medium flow rates

EZstrip™ Hose Pump models ZH1390 and ZH1440 cover the range of medium flow rates between 250 and 3,500 l/h.

The competitiveness of these models from an economic and technological point of view positions this product range as unrivaled on the market. It is a highly efficient and heavy duty unit with a hose compression system that provides maximum accuracy, effectiveness, and durability.

The lack of valves and mechanical seals, dry running capability, and great suction power make the EZstrip™ Hose Pump the best option for dosing or transferring highly abrasive, shear sensitive, viscous, or corrosive products.

The robustness of the ZH1390 and ZH1440 pumps is based on the two integrated bearings, which absorb the axial loads between the rotor and the reducer, a rotor assembly, and XXL rollers with maximum performance and innovative design. The compact, easy mounting system combines with robust construction materials that are fully treated with the latest hardening and anti-corrosion processes on the market.

Like the smaller EZstrip™ Hose Pumps, these two models feature the same robustness and durability philosophy focused on a very compact, vertical design with a hose compression system using XXL rollers. This hose-squeezing system offers maximum surface contact with a differentiated and technically advanced manufacturing process of each peristaltic hose, maximizing the service life of this component and reducing and optimising maintenance and operating costs.

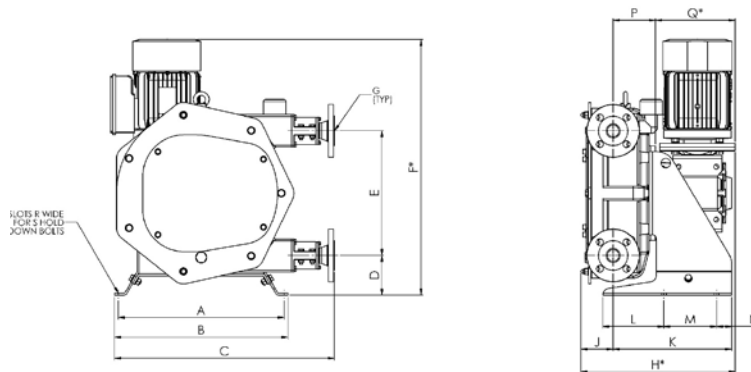

Model	A	B	C	D	E	F*	G	H*	J
ZH1390	390mm	410mm	517mm	98mm	264mm	627mm	DN 25 BS ¹	383mm	76mm
	15.35"	16.14"	20.35"	3.86"	10.39"	24.69"	1" ANSI ²	15.08"	2.99"
ZH1440	440mm	460mm	583mm	105mm	330mm	677mm	DN 32 BS ¹	409mm	85mm
	17.32"	18.11"	22.95"	4.13"	12.99"	26.65"	1 1/4" ANSI ²	16.1"	3.35"

Model	K	L	M	N	P	Q*	R	S
ZH1390	280mm	132mm	140mm	40mm	96mm	211mm	12mm	M10mm
	11.02"	5.2"	5.51"	1.58"	3.78"	8.31"	0.47"	3/8"
ZH1440	314.5mm	162mm	140mm	40mm	112.5mm	211mm	12mm	M10mm
	12.38"	6.38"	5.51"	1.58"	4.43"	8.31"	0.47"	3/8"

1. BS flanges to DIN1092-1 PN16
 2. ANSI flanges to ANSI B16.5 Class 150
 Standard configurations shown
 *Depending on the driver, dimensions could change.

Technical specifications	Model ZH1390
Max. flow (continuous)	1900 l/h (8.37 GPM)
Capacity	0.47 l/rev (0.12 g/rev)
Max. discharge pressure	10 bar (145 PSI)
Max. temperature	80 °C (176°F)
Inner diameter	28 mm (1.1")
Hose material	NR, EPDM, and NBR (food grade)
Connections	AISI-316, PP, PVDF (PTFE)

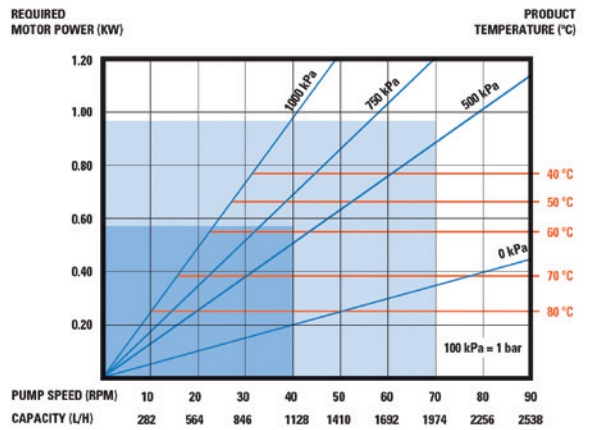

Technical specifications	Model ZH1440
Max. flow (continuous)	3600 l/h (15.85 GPM)
Capacity	0.89 l/rev (0.24 g/rev)
Max. discharge pressure	10 bar (145 PSI)
Max. temperature	80 °C (176°F)
Inner diameter	35 mm (1.38")
Hose material	NR, EPDM, and NBR (food grade)
Connections	AISI-316, PP, PVDF (PTFE)

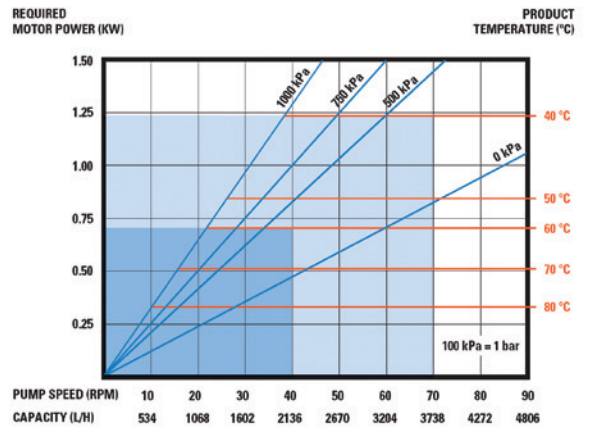

Models ZH1550, ZH1660

Transfer and dosing with maximum efficiency and durability

The ZH1550 and ZH1660 models complete the EZstrip™ Hose Pump line with a flow rate range between 1,000 and 17,000 l/h. This can be extended by means of a double-head pump up to 34,000 l/h. These two models are perfect for dosing operations of all types of products, where, thanks to the excellent flow rate control, to the constant flow rate in variable pressure applications, and to the gentle pumping, accuracies of up to ±1% can be achieved.

They are also ideal for transfer applications of fluids that are highly abrasive, viscous, or contain solids in suspension, as the pump has a large solid size capacity. The lack of valves and mechanical seals, in addition to the heavy duty and horizontal monoblock design with bearing box, makes the EZstrip™ Hose Pump a very robust and ideal option for any pumping application. The indefinite dry running and the suction capacity of up to 9.5 mWc complements the capacities of the EZstrip™ Hose Pump product range.

The installation of the bearing box in the pump casing provides perfect alignment and full absorption of the loads on the reducer shaft. The bearing box is made up of a central hub, which supports the reinforced and oversized bearings and the pump shaft. The incorporation of this assembly provides unbeatable strength to the pump, even in the most severe conditions. The models reduce maintenance costs and downtime while extending the life of the reducer.

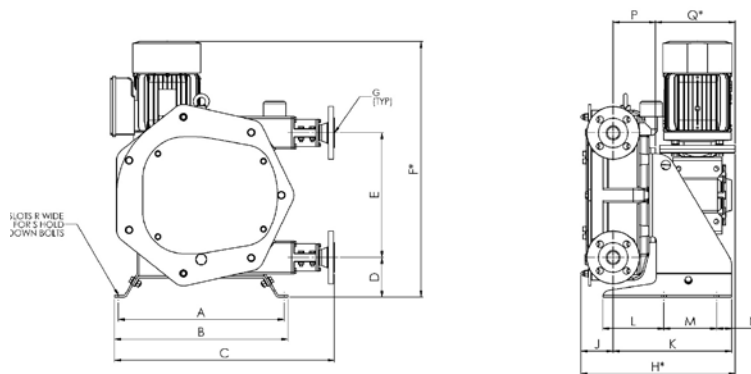

Model	A	B	C	D	E	F*	G	H*	J
ZH1550	550mm	580mm	700mm	110mm	430mm	655mm	DN 40 BS ¹	801mm	97mm
	21.65"	22.84"	27.56"	4.33"	16.93"	25.79"	1 ½" ANSI ²	31.54"	3.82"
ZH1660	660mm	690mm	820mm	143mm	554mm	820mm	DN 50 BS ¹	947mm	107mm
	25.98"	27.17"	32.28"	5.63"	21.81"	32.28"	2" ANSI ²	37.28"	4.21"

Model	K	L	M	N	P	Q*	R	S
ZH1550	402mm	148.5mm	250mm	50mm	142mm	564mm	16mm	M12mm
	15.83"	5.85"	9.84"	1.97"	5.59"	22.21"	0.63"	½"
ZH1660	514.5mm	129mm	39.5mm	380mm	156.5mm	684mm	16mm	M12mm
	20.26"	5.08"	1.56"	14.96"	6.16"	26.93"	0.63"	½"

1. BS flanges to DIN1092-1 PN16
 2. ANSI flanges to ANSI B16.5 Class 150
 Standard configurations shown
 *Depending on the driver, dimensions could change.

Technical specifications	Model ZH1550
Max. flow (continuous)	7000 l/h (30.82 GPM)
Capacity	1.69 l/rev (0.45 g/rev)
Max. discharge pressure	10 bar (145 PSI)
Max. temperature	80 °C (176°F)
Inner diameter	43 mm (1.69")
Hose material	NR, EPDM and NBR (food grade)
Connections	AISI-316, PP, PVDF (PTFE)

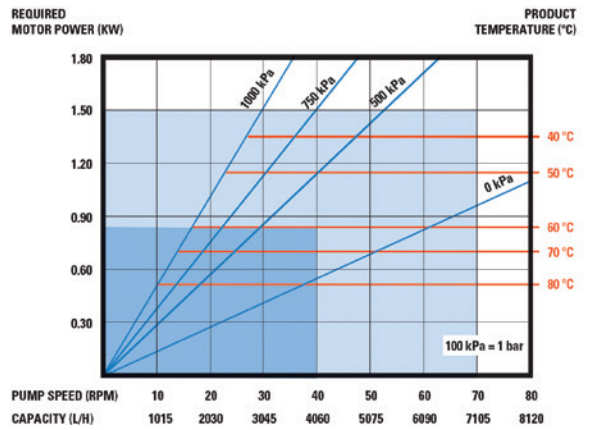

Technical specifications	Model ZH1660
Max. flow (continuous)	13000 l/h (57.24 GPM)
Capacity	3.71 l/rev (0.98 g/rev)
Max. discharge pressure	10 bar (145 PSI)
Max. temperature	80 °C (176°F)
Inner diameter	55 mm (2.17")
Hose material	NR, EPDM and NBR (food grade)
Connections	AISI-316, PP, PVDF (PTFE)

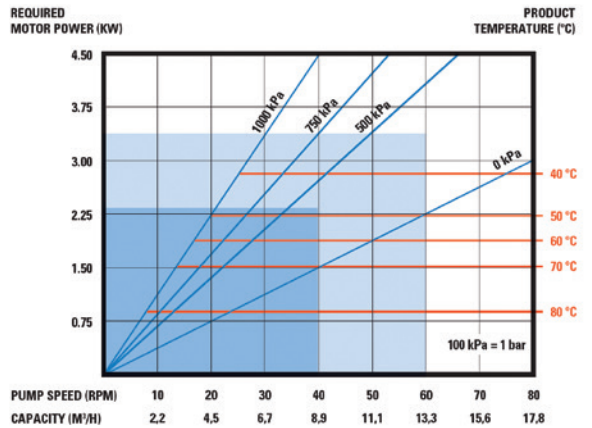

Chemical version

The best solution for dosing corrosive products.

The chemical version of the EZstrip™ Hose Pump is resistant to highly corrosive acids and difficult chemicals.

This version is principally made up of:

- The latest generation peristaltic hose in NR or EPDM
- Pump casing and front cover coating in TEFZEL®
- Plastic connections in polypropylene or PVDF
- Hose leakage
- Pump and roller lip seals in EPDM
- Corrosion resistant rollers
- Drainage system

As result of these specifications, we achieve a fully corrosion resistant, strong and heavy duty pump at a very competitive price.

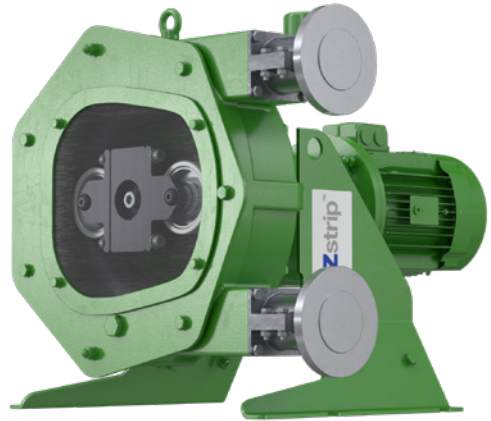

Recommended applications for the chemical version:

- Sodium hypochlorite dosing
- Ferric chloride dosing
- Hydrochloric acid dosing
- Sulphuric acid dosing
- And other acidic liquids

Food grade version

A new concept for pumping of food grade products.

The food grade version of the EZstrip™ Hose Pump is compatible with food and beverage and cosmetic products. The sanitary pump which meets the current specifications and regulations.

This version is principally made up of:

- The latest generation peristaltic hose in FDA food grade nitrile
- DIN 11851 or tri-clamp sanitary connections
- Removable front cover aids in CIP cleaning processes
- Front removal roller
- Stainless steel base plate and cover
- Pump casing painted in sanitary white

The use of this version optimises downtimes, facilitates cleaning processes, and improves efficiency. The innovative peristaltic hose manufacturing process provides extra resistance against temperature, lengthens service life, and reduces maintenance costs.

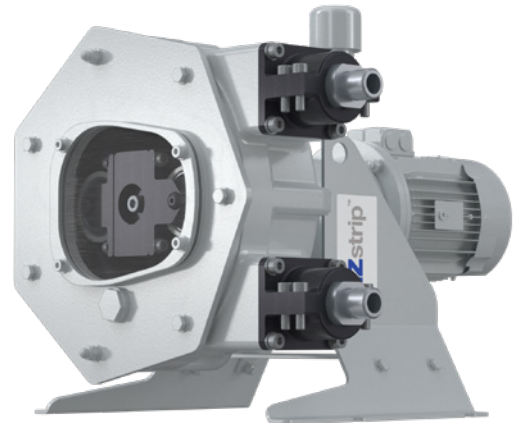

Recommended applications for the food version:

- Transfer of juices and sauces
- Dosing of additives, colourings, flavourings, and enzymes
- Pumping of food products such as drinks, dairy, and confectionery
- Yeast pumping
- Oil pumping
- Wine transfer

Applications

Water treatment

- Transfer of sludges and slurries
- Dosing of activated carbon and lime milk
- Dosing of sodium hypochlorite and ferric chloride
- Dosing of polymers and flocculants
- Sampling

Chemical industry

- Dosing of pigments and water-based paints
- Transfer of highly abrasive products such as titanium dioxide
- Dosing of resins
- Dosing of detergents, creams, and water-based glues
- Dosing of all types of acid or base corrosive chemicals

Mining industry

- Transfer of mineral pulp, sludges, and slurries
- Dosing of cyanide and xanthate
- Transfer or dosing of polymers
- Dosing of reagents

Food and beverage and cosmetics

- Pumping of diatomaceous earth
- Transfer of viscous juices and sauces or ones with solid pieces in the mixture
- Various additives, colourings, and flavourings for food
- Feeding to filling machines

Ceramics and construction industry

- Dosing of very abrasive products such as barium carbonate and potassium permanganate
- Transfer of ceramic barbotine
- Dosing of additives and colourings for the cement
- Transfer of low-density cement

Paper industry

- Dosing of chemicals and paint
- Transfer of paper pulp
- Dosing of lime milk
- Dosing of additives and colourings
- Dosing and transfer of glues

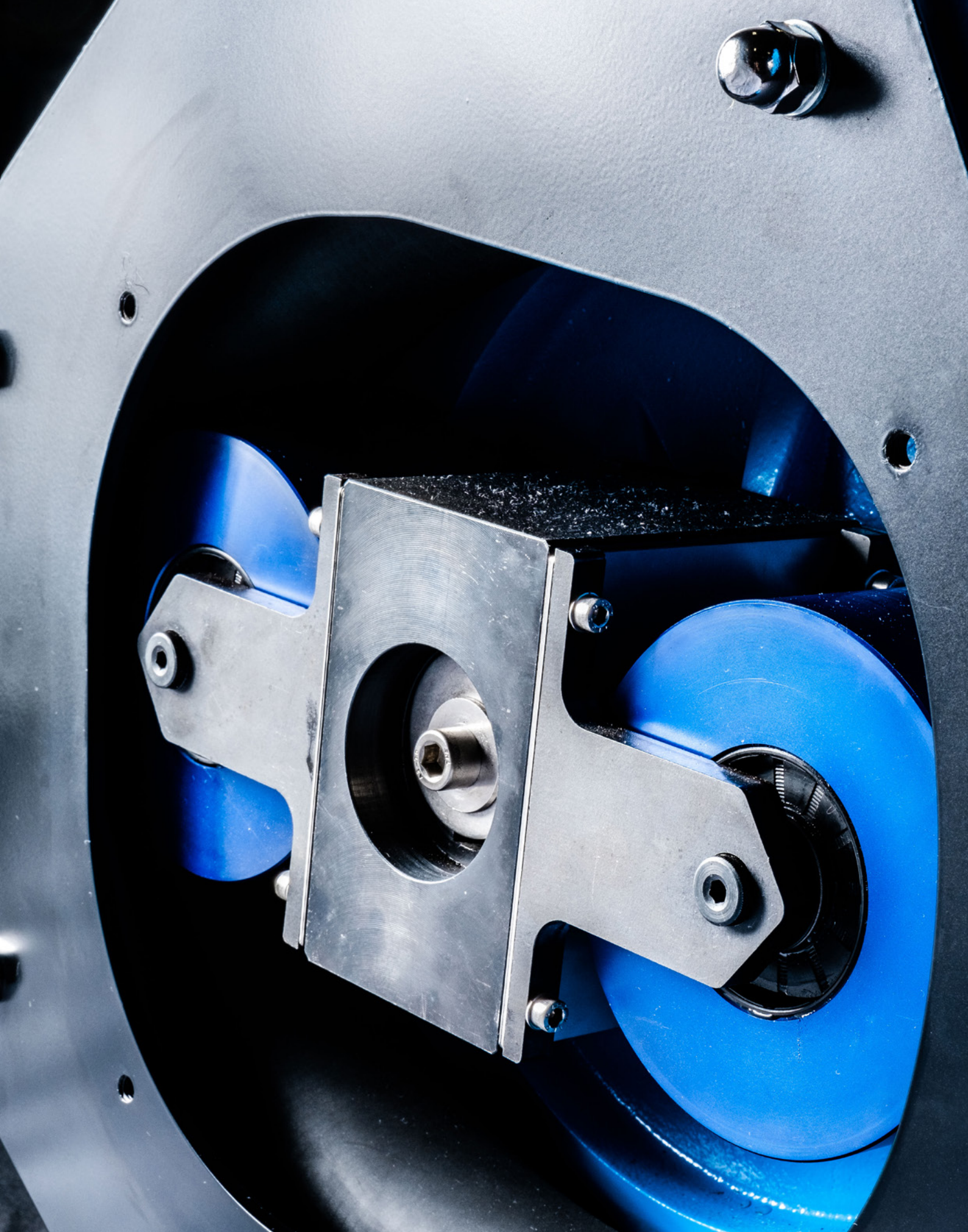

National Oilwell Varco has produced this brochure for general information only, and it is not intended for design purposes. Although every effort has been made to maintain the accuracy and reliability of its contents, National Oilwell Varco in no way assumes responsibility for liability for any loss, damage or injury resulting from the use of information and data herein. All applications for the material described are at the user's risk and are the user's responsibility.

©2019 National Oilwell Varco. All rights reserved.
Compass 002134 v1 | JIRA 9751

Corporate Headquarters
7909 Parkwood Circle Drive
Houston, Texas 77036
USA

**Completion and Production
Solutions Headquarters**
10353 Richmond Avenue
Houston, Texas 77042
USA



industrial@nov.com

nov.com/industrial