



Original
Instructions

Installation, Operation and Maintenance Instructions

L Series Discreen

Index

REVISIONS	3
SPARES AND SERVICE CONTACTS	4
ATEX WARNINGS	5
INTRODUCTION	8
EC DECLARATION	7
INSTALLATION, OPERATION AND MAINTENANCE	8
ESSENTIAL HEALTH AND SAFETY	8
SYSTEM DESIGN AND INSTALLATION	9
INSTALLATION GUIDELINES	12
DISCREEN CODING	15
VIEWS AND SECTIONAL ARRANGEMENTS:	
200mm to 500mm THROAT	16
750mm to 1750mm THROAT	21
MAINTENANCE:	
SCHEDULED MAINTENANCE	26
LUBRICATION SCHEDULE	27
DISMANTLING AND ASSEMBLY PROCEDURE	28
LOCTITE DIAGRAMS	38
OIL FILLED MACHINE HARDWARE DETAILS	40
RE-ASSEMBLY AND TORQUE SETTINGS	41
STANDARD DRIVE POSITIONS	42
WIRING DIAGRAM	44
GENERAL ARRANGEMENT DRAWINGS:	
200mm to 500mm THROAT – GENERAL ARRANGEMENT	45
750mm to 1750mm THROAT – GENERAL ARRANGEMENT	46

Spares and Service Contacts

UK

Spares	+44 (0)161 214 2380 (direct line 8.15 am – 5.00 pm)
E-mail	ManchesterSpares@nov.com
Service	+44 (0)161 214 2390 (direct line 8.15 am – 5.00 pm)
E-mail	Customer.Services@nov.com
Service	+44 (0)161 339 9000 (24 hrs)

France

Spares & Service	+33 (0)3 29 94 26 88
E-mail	monofrance@nov.com

Australia

Melbourne	(03) 9773 7777
Sydney	(02) 8536 0900
Brisbane	(07) 3350 4582
Adelaide	(08) 8132 6800
Perth	(08) 9320 5800
Darwin	(08) 8931 3300
E-mail	ozsales@nov.com

New Zealand

Spares & Service	+64 (0)9 829 0333
E-mail	info@mono-pumps.co.nz

USA

Houston Spares & Service	+1 281 854 0300
Ohio Spares & Service	+1 877 486 6966
E-mail	moyno@nov.com

China

Beijing	+86 (0) 10 5707 0900
Shanghai	+86 (0) 21 3990 4558
E-mail	monoshanghai@nov.com

Distributors

For local distribution, please refer to our website:

www.mono-pumps.com/en-uk/sales_network



SCREENS

Due to the nature and design of screening equipment it is possible that certain objects may enter the screening mechanism, from the process stream, with the potential to cause sparking or jamming of the mechanism.

Where a screen is to be installed in a potentially explosive atmosphere ensure that this has been specified at the time of purchase and that the equipment has been supplied accordingly and displays an ATEX nameplate or is supplied with a certificate of conformity. If there is any doubt as to the suitability of the equipment please contact your Supplier before commencing with installation and commissioning.

Process liquids or fluids should be kept within specified temperature limits otherwise the surface of screen or system components may become an ignition source due to temperature rises. Where the process liquid temperature is less than 90°C (194°F) the maximum surface temperature will not exceed 90°C (194°F) provided the screen is installed, operated and maintained in accordance with this manual. Where the process fluid temperature exceeds 90°C (194°F) the maximum surface temperature will be equal to the maximum process fluid temperature.

Cavities that could allow the accumulation of explosive gases, such as under guards, should where possible, be designed out of the system. Where this is not possible they should be fully purged before any work is carried out on the screen or system.

Electrical installation and maintenance work should only be carried out by suitably qualified and competent persons and must be in accordance with relevant electrical regulations.

All electrical equipment, including control and safety devices, should be suitably rated for the environment in to which they are installed.

Where there may be a risk of an accumulation of explosive gases or dust non-sparking tools should be used for installation and maintenance.

To minimise the risk of sparking or temperature rises due to mechanical or electrical overload the following control and safety devices should be fitted. A control system that will shut the screen down if the motor current or temperature exceed specified limits or a jam of the screening mechanism occurs. This may include a system that reverses the machine in order to clear any such jam. An isolator switch that will disconnect all electrical supply to the motor and ancillary electrical equipment and be capable of being locked in the off position.

All control and safety devices should be fitted, operated and maintained in accordance with the manufacturer's instructions.

It is important that the screen rotates in the correct direction to give an efficient screening operation and ensure that debris is moved away from the screen as it should. This must be checked on installation and commissioning and after any maintenance has been carried out. Failure to observe this may lead to mechanical or electrical overload.

When fitting drives, couplings, and guards to a screen unit it is essential that these are correctly fitted, aligned and adjusted in accordance with the O&M instructions. Failure to do so may result in sparking due to unintended mechanical contact or temperature rises due to mechanical or electrical overload.

Mechanical seals should be suitably rated for the environment. The seal and any associated equipment, such as a flushing system, must be installed, operated and maintained in accordance with the manufacturer's instructions.

Where a packed gland seal is fitted this must be correctly fitted and adjusted. This type of seal relies on the process liquid to cool the shaft and packing rings so a constant drip of liquid from the gland section is required. Where this is undesirable an alternative seal type should be fitted.

Failure to operate or maintain the screen and ancillary equipment in line with the manufacturer's instructions may lead to premature and potentially dangerous failure of components.

Regular inspection, and where necessary replacement, of bearings, seals, other wearing parts and lubrication is essential.

The screen and its components have been designed to ensure safe operation within the guidelines covered by legislation. Accordingly your Supplier has declared the machine safe to use for the duty specified as defined by the Declaration of Incorporation or Conformity that is issued with this instruction manual. The use of replacement parts that are not manufactured by or approved by your Supplier may affect the safe operation of the screen and it may therefore become a safety hazard to both operators and other equipment. In these circumstances the Declaration provided will become invalid. The guarantee referenced on the Terms and Conditions of Sale will also be invalidated.

Introduction

L Series Discreen

This information and all the information contained herein, is the exclusive property of your Supplier, and contains information of a proprietary nature. It is provided for the sole purpose of transmitting the information contained to the designated recipient.

This information is to be used only as specified in the instrument of transmittal. It is not to be reproduced, copied in whole, or in part, nor is information it contains to be disclosed in any manner without the written consent of your Supplier Its

use for any other reason than the specified shall be a violation of the agreement with the recipient concerning the legal rights of your Supplier.

Your Supplier reserves the right to make changes, which may obsolete certain parts of this manual.

The manual gives a guide to the operation and maintenance of the L Series Discreen given that all Health and Safety and good engineering practices are observed.

EC Declaration as defined by Machinery Directive 2006/42/EC.

The following harmonised standards are applicable: BS EN ISO 12100: 2010

EC Declaration of Incorporation

This declaration is only valid when partly completed machinery has been supplied.

In this case, the machinery meets the requirements of the said directive and is intended for incorporation into other machinery or for assembly with other machinery in order to constitute relevant machinery as defined by the said directive including any amendments, which are valid at the time of supply.

IMPORTANT

This machinery must not be put into service until the relevant machinery into which it is to be incorporated has been declared in conformity to the said directive.

This declaration is only valid when the machinery has been installed, operated and maintained in accordance with these instructions and safety guidelines contained within as well as instructions supplied for equipment assembled with or intended for use with this equipment.

EC Declaration of Conformity

This declaration is not valid for partly completed machinery that has been supplied.

In this case the machinery meets the requirements of the said directive including any amendments which are valid at the time of supply.

We further declare that, where applicable, said machinery also meets the requirements of:

The EMC Directive 2014/30/EU
The Low Voltage Directive 2014/35/EU
The Pressure Equipment Directive 2014/68/EU

IMPORTANT

This declaration is only valid when the machinery has been installed, operated and maintained in accordance with these instructions and safety guidelines contained within as well as instructions supplied for equipment assembled with or intended for use with this equipment.



**Mr A. Morris - Director of Pump Technology for
NOV PFT UK Ltd., Greengate Way, Middleton,
Manchester, England, M24 1SA.**

Installation, Operation and Maintenance

1.0 ESSENTIAL HEALTH AND SAFETY

1.1 INSTALLATION AND SAFETY RECOMMENDATIONS

In common with other items of process plant an L Series Discreen must be correctly installed to ensure satisfactory and safe operation. The L Series Discreen must also be maintained to a suitable standard. Following these recommendations will ensure that the safety of personnel and the satisfactory operation of the L Series Discreen is achieved.

1.1.1 GENERAL SAFETY

The noise sound pressure level will not exceed 70dB at one metre distance from the machine. This is based on a typical installation and does not necessarily include noise from other sources or any contribution from building reverberation.

The warning sign supplied with the L Series Discreen should be clearly displayed in close proximity to the machine.

The installation, repair and maintenance of the L Series Discreen should only be carried out by persons with the relevant experience and training.



Before any work is carried out on the L Series Discreen or motor controller, be certain the main line breaker is open and tagged. Serious injury could result from accidental start up.

When checking for correct direction of rotation all personnel should be well clear of the L Series Discreen.

Due to the nature of the types of fluid screened by the L Series Discreen it is recommended that the machine be steam cleaned prior to any work being carried out.

This will reduce the risk of any biological or microbiological contamination. Where the necessary equipment is not available the L Series Discreen should be thoroughly washed down with clean water. The motor and drive unit should not be steam cleaned or washed down unless it is suitably rated.



Where your Supplier has supplied a bare shaft L Series Discreen the onus is on the user to fit adequate guards in compliance with the requirements of the relevant regulations.



All nuts, bolts securing flanges and mounting fixtures should be checked for tightness prior to operation of the L Series Discreen. All guards should be securely fixed and in compliance with current legislative requirements. May contain substances from the ECHA SVHC

Candidates List (REACH - Regulation (EC) No. 1907/2006)

1.2.1 GENERAL

The L Series Discreen basically consists of a number of shafts each fitted with overlapping and intermeshing discs with an aperture distance to suit the fineness of screening required.

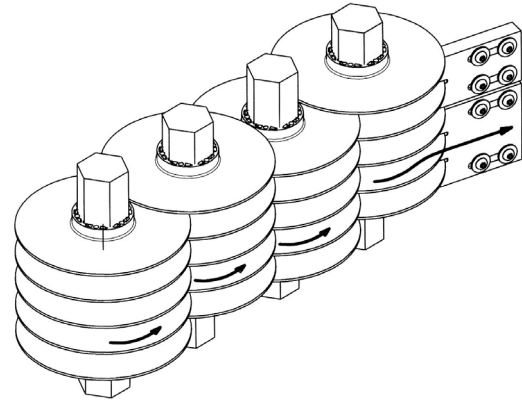

Figure 1
Operating Principle

Each shaft rotates at the same speed as its upstream neighbour forming a gentle conveying action of solids across the face to the discharge point at the comb bars as shown in Figure 1.

To ensure efficient operation and to prevent overload of The PLC incorporates the same reversal logic as the timer with the following additional functionality.

By continuously monitoring the absorbed power of the motor it is able to detect potential overload conditions and will reverse or trip the motor to prevent mechanical damage to the Discreen. When an increase in absorbed power is detected the PLC will stop and reverse the machine in an attempt to clear any blockage. If the overload persists it will reverse the unit again up to a maximum of three times in one minute. If more than three overloads occur in a one minute period the PLC will trip out the unit and generate an alarm signal. A reversal will occur if the absorbed power exceeds 105% full load for 30 seconds or 133% full load for 5 seconds or 150% full load for 0.1 seconds.

Motor Power	Market	Control Voltage	Control Device	Mono Part No.
0.75kW (1HP)	UK and Australia	110v	Timer	DC
	Mainland Europe	24v		EDC
1.1kW (1.5HP)	UK and Australia	110v	Timer	DC
	Mainland Europe	24v		EDC
1.5kW (2HP)	UK and Australia	110v	Timer	DC
	Mainland Europe	24v		EDC
2.2kW (3HP)	UK and Australia	110v	PLC	DPLC22
	Mainland Europe	24v		EDPLC22
3.0kW (4HP)	UK and Australia	110v	PLC	DPLC30
	Mainland Europe	24v		EDPLC30

Table 1 - Timer or PLC Selection

If you require further clarification please contact your Supplier



When handling harmful or objectionable materials adequate ventilation must be provided in order to disperse dangerous concentrations of vapours.

It is recommended that wherever possible the L Series Discreen should be installed with provision for adequate lighting, thus ensuring that effective maintenance can be carried out in satisfactory conditions. With certain product materials a steam cleaning or hosing down facility will simplify maintenance and prolong the life of L Series Discreen components.

1.2.2. SYSTEM DESIGN AND INSTALLATION

At the design stage due consideration must be given to the design of the civil works. These must have sufficient mechanical integrity to support the imposed loads due to the weight of the L Series Discreen and the hydraulic loads due to the flow conditions.

The L Series Discreen should be bolted to the channel wall via suitable steelwork or mounted in a purpose built support frame.

1.3.1. HANDLING



During installation and maintenance, attention must be paid to the safe handling of all items.



Where a Discreen component weighs in excess 20kg it is recommended that suitable lifting tackle be used to ensure that personal injury or damage to the components does not occur.

Where slings are used for lifting components the sling positions should be selected according to the size and shape of the component.

Lifting should be carried out by personnel with relevant experience to ensure that personal injury or damage to the components does not occur.

If eyebolts do exist they should only be used for lifting the individual component for which they are supplied.

Lifting of the assembled L Series Discreen should only be via the designated lifting points using the purpose designed lifting equipment supplied with the machine. Lifting equipment should be rated for the maximum weights.

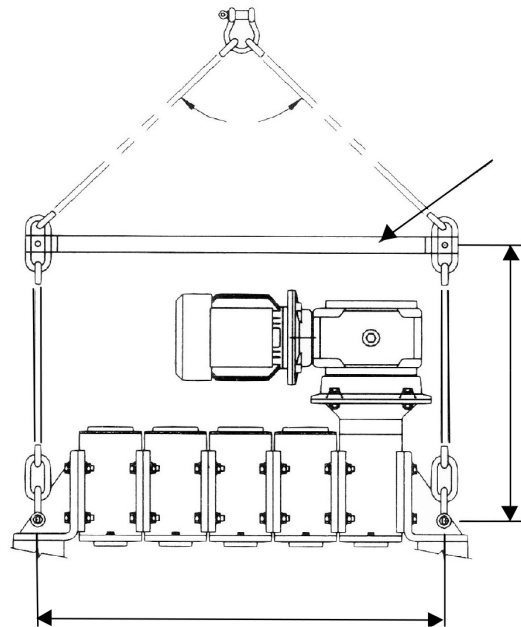

Figure 2

Typical L Series Discreen Lifting points and Spreader Bar Assembly



Due to the inherent instability of the L Series Discreen it should not be left free standing, as this constitutes a serious crushing risk. It is essential that it is either laid flat or securely supported by some external means.

1.3.2. STORAGE

The L Series Discreen units are dispatched from our factory ready for immediate installation and operation.

Where the L Series Discreen has to be stored prior to installation the following procedure is advised:-

- (1) Store the L Series Discreen inside wherever possible. If this is not feasible a protective covering should be

provided. Do not allow moisture to collect around the L Series Discreen.

- 2) At monthly intervals the shafts should be rotated to prevent the seal faces from sticking. This is most easily achieved by removing the motor fan cowl and turning the fan by hand.
- (3) For information regarding storage of the motor and drive unit refer to the manufacturer's instructions.

Note: Care should be taken when handling either the L Series Discreen or the control panel to prevent damage to the paintwork etc.

1.4 ELECTRICAL



Electrical connection should only be made by suitably qualified personnel using equipment suitable for both the rating and the environment. Where any doubts exist regarding the suitability of equipment, Your Supplier should be consulted before proceeding. Earthing points will be provided on electric drives (if supplied) and it is essential that these be correctly connected. The electrical installation should include appropriate isolating equipment to ensure the L Series Discreen is safe to work on.

The control logic in the panel is programmed to give periodic reversal of the shafts / disc stacks (typically 10 seconds each hour) which is essential for the self-cleaning process on the discharge comb bars.

1.5 DUTY CONDITIONS

The L Series Discreen should only be installed on duties for which your Supplier has specified the materials of construction, flow rates and head conditions etc.

If the duty conditions should be changed, your Supplier should be contacted and their recommendations sought in the interest of application, plant safety and Discreen life.

2.0 INSTALLATION

2.1 CHANNEL INSTALLATION



The L Series Discreen does not require fixing to the ground. In general the units can be supported either by the concrete channel or by steel supports bolted to the channel walls. The supports must provide adequate stability of the L Series Discreen.

2.2 INSTALLATION GUIDELINES

2.3 Machine configuration

The Discreen should be configured to suit the installation and application. The comb bars are orientated depending on whether the screen is installed on the left or right of an inlet channel or in a storm or abstraction application. Refer to Figure 4 and the coding sheet for details.

2.4 Channel Design Recommendations

The design of the channel should be such that it promotes flow across the face of the screen and prevents the build up solids in 'dead areas'.

Where the Discreen is installed in conjunction with a Muncher or extractor it is recommended that the Discreen be raised to promote flow through the Muncher or extractor at low flows. Where this is done the channel should be benched as shown in Figure 6 to prevent build up of solids at the base of the machine. The use of a dry weather channel will help maintain fluid velocity and reduce the likelihood of solids deposition at low flows.

2.5 Design of Supporting Framework

The supporting framework should be designed such that it promotes a clear passage of solids across the Discreen and back in to the foul flow. There should be no areas which allow solids to collect as they will quickly build up and reduce the efficiency of the Discreen.

Where impact from large objects such as tree branches is likely we recommend that deflector bars are fitted in front of the machine to prevent damage to the discs or shafts. Figure 7 shows a typical support frame design.

The supporting framework should have sufficient mechanical strength to resist all mechanical and hydraulic loads it is likely to be subjected to.

Your Supplier is able to supply custom made support frames which are specifically designed to suit the equipment and the installation requirements. Where support frames not approved by us are used we can not be held responsible if performance of the Discreen is affected by their design or method of installation.

2.6 Guide Rail Systems

Where the Discreen is installed in an area where access is difficult, it is recommended that a guide rail system be used to aid removal for inspection and maintenance. Please contact your Supplier for further information on guide rail systems.

Wherever possible an adjustable handstop should be located 1 to 2 metres (3.28 - 6.56 feet) upstream of the L Series Discreen. In operation this should be lowered until approximately 150mm (5.9") is submerged at the duty point. This will promote turbulent flow giving a self-cleansing action in the inlet area. Refer to Figure 3 for further details.

IF THE L SERIES DISCREEN IS TO BE MOUNTED IN ANY OTHER WAY THAN DESCRIBED ABOVE, CONFIRMATION OF THE INSTALLATION MUST BE AGREED WITH YOUR SUPPLIER

3.0 START-UP PROCEDURE

(1) Once the L Series Discreen has been installed in its correct operating position the gearbox and bearing housing should be checked for the correct amount of oil. Refer to the manufacturer's recommendations.

(2) **By the nature of the equipment and its operating environment the L Series Discreen can be an extremely dangerous machine**



(3) **Always ensure that the L Series Discreen is guarded in compliance with current legislative requirements before any attempt to operate it is made.**



(4) On start-up check the direction of rotation of the discs. The discs should rotate towards the discharge end. If the direction of rotation is incorrect, ensure the main breaker is open and tagged and then reverse any two of the motor input leads.

(5) **This work should only be carried out by suitably qualified personnel. When checking the direction of rotation of the discs always ensure that all personnel are well clear of the discs.**

Under no circumstances should the 750mm (29.5") to 1750mm (70") L Series Discreen be run with the bottom mechanical seal dry. This will lead to overheating of the seal faces and will cause premature seal failure.

INSTALLATION GUIDELINES

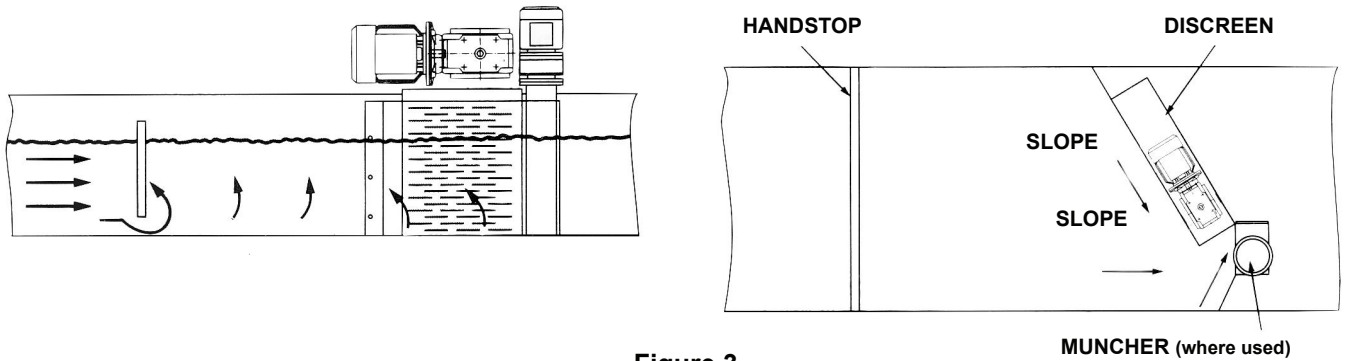

Figure 3
Hand Stop

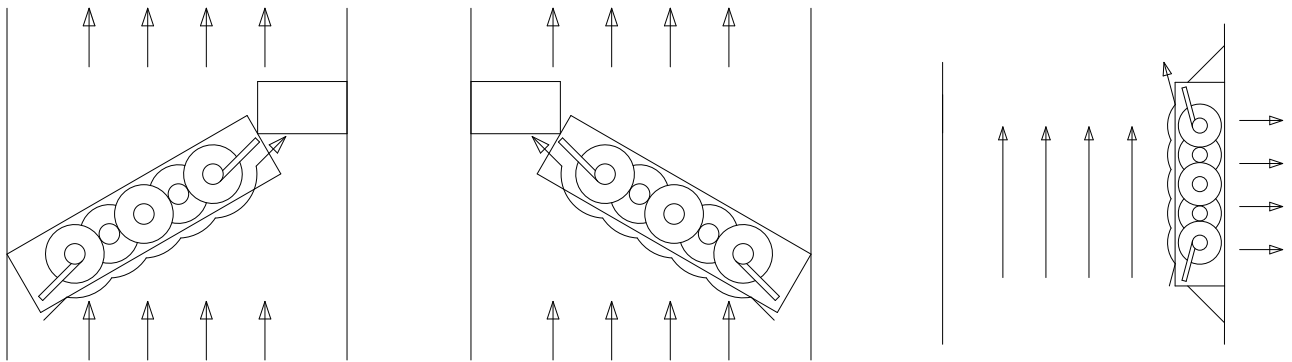

Figure 4a
Left hand channel
installation

Figure 4b
Right hand channel
installation

Figure 4c
Storm or abstraction

Where the Discreen is installed in an inlet channel it should be at a minimum of 30° to the flow as shown in Figure 5.

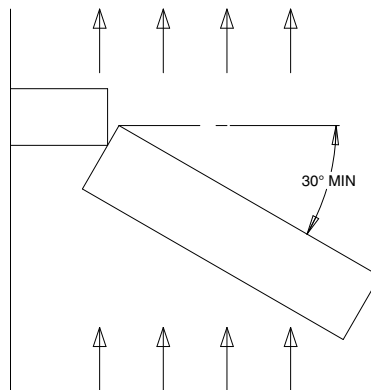

Figure 5
Minimum installation angle

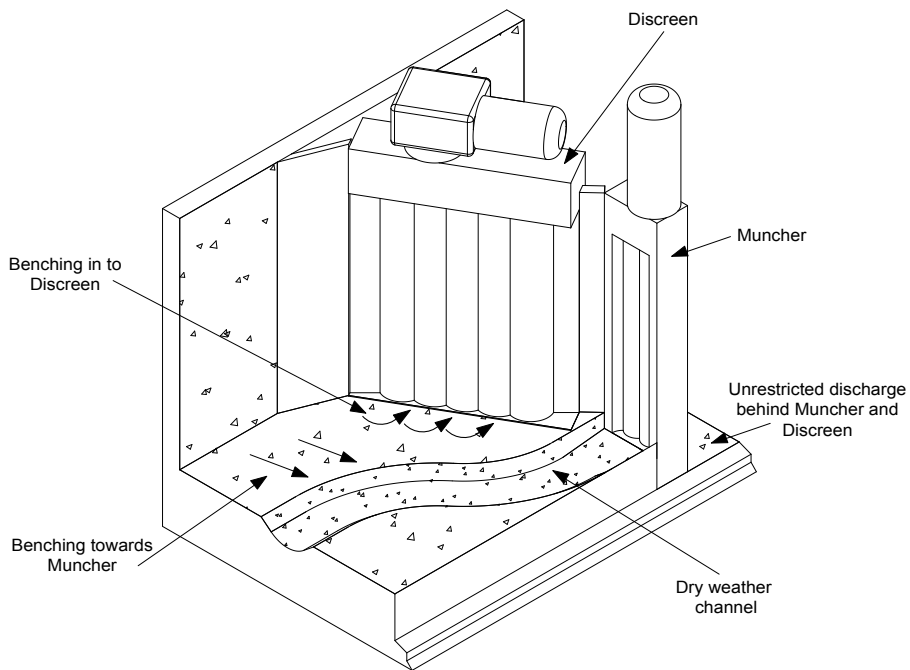

Figure 6
Recommended channel design

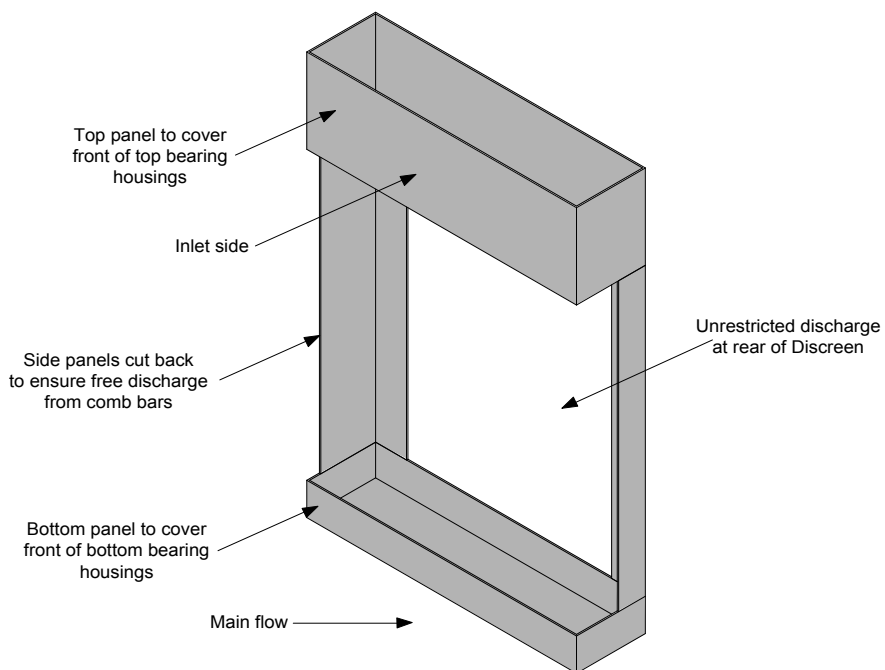

Figure 7
Support frame

Weights

Machine Code	Dimension 'A' (mm)	Maximum Weight (kg)
CL1203	574	225
CL1204	710	251
CL1205	846	277
CL1206	982	303
CL1207	1118	329
CL1208	1254	355
CL1209	1390	381
CL1210	1526	407
CL1303	574	245
CL1304	710	279
CL1305	846	313
CL1306	982	347
CL1307	1118	381
CL1308	1254	415
CL1309	1390	449
CL1310	1526	483
CL1403	574	260
CL1404	710	301
CL1405	846	342
CL1406	982	383
CL1407	1118	424
CL1408	1254	465
CL1409	1390	506
CL1410	1526	547
CL1503	574	280
CL1504	710	330
CL1505	846	380
CL1506	982	430
CL1507	1118	480
CL1508	1254	530
CL1509	1390	580
CL1510	1526	650

Machine Code	Dimension 'A' (mm)	Maximum Weight (kg)
ML1A03	574	505
ML1A04	710	620
ML1A05	846	735
ML1A06	982	850
ML1A07	1118	965
ML1A08	1254	1080
ML1A09	1390	1195
ML1A10	1526	1310
ML1B03	574	590
ML1B04	710	725
ML1B05	846	860
ML1B06	982	995
ML1B07	1118	1135
ML1B08	1254	1275
ML1B09	1390	1410
ML1B10	1526	1550
ML1C03	574	655
ML1C04	710	815
ML1C05	846	975
ML1C06	982	1135
ML1C07	1118	1295
ML1C08	1254	1455
ML1C09	1390	1615
ML1C10	1526	1775
ML1D03	574	755
ML1D04	710	935
ML1D05	846	1115
ML1D06	982	1295
ML1D07	1118	1475
ML1D08	1254	1660
ML1D09	1390	1845
ML1D09	1526	2025
ML1E03	574	835
ML1E04	710	1040
ML1E05	846	1240
ML1E06	982	1445
ML1E07	1118	1645
ML1E08	1254	1850
ML1E09	1390	2055
ML1E10	1526	2260

Discreen Coding

Features	Description	Basic Code										Variation		13		
		1	2	3	4	5	6	7	8	9	10	11	12			
Body Material	Cast Iron Body/ Plastic Discs	C														
	Cast Iron Body/ SS Discs/ SS Spacers	M														
Product	L Series Discreen		L													
Mark Number	May-98			1												
	Mar-05			2												
	Jun-13			3												
	Jan-15			4												
Nominal Throat Size	200mm (8")				2											
	300mm (12")				3											
	400mm (16")				4											
	500mm (20")				5											
	750mm (30")				A											
	1000mm (40")				B											
	1250mm (50")				C											
	1500mm (60")				D											
Number of Shafts	3					0	3									
	4					0	4									
	5					0	5									
	6					0	6									
	7					0	7									
	8					0	8									
	9					0	9									
	10					0	10									
Build Option	Refer to your Supplier								*							
Screen Aperture Size	2.5mm (0.0984")									B						
	5.0mm (0.1969")									M						
	9.0mm (0.3543")									N						
Configuration	Left Hand Build										L					
	Right Hand Build										R					
	Storm Build-750 to 1750mm Throats										S					
Oblique	-											\				
Field Variation	-												V	A		R
Typical Code	-	C	L	3	B	0	6	*	M	S	\	1	2			3

Note: "X" in any column denotes a special variation.

Exploded View

200mm to 500mm Throat - L000 9820

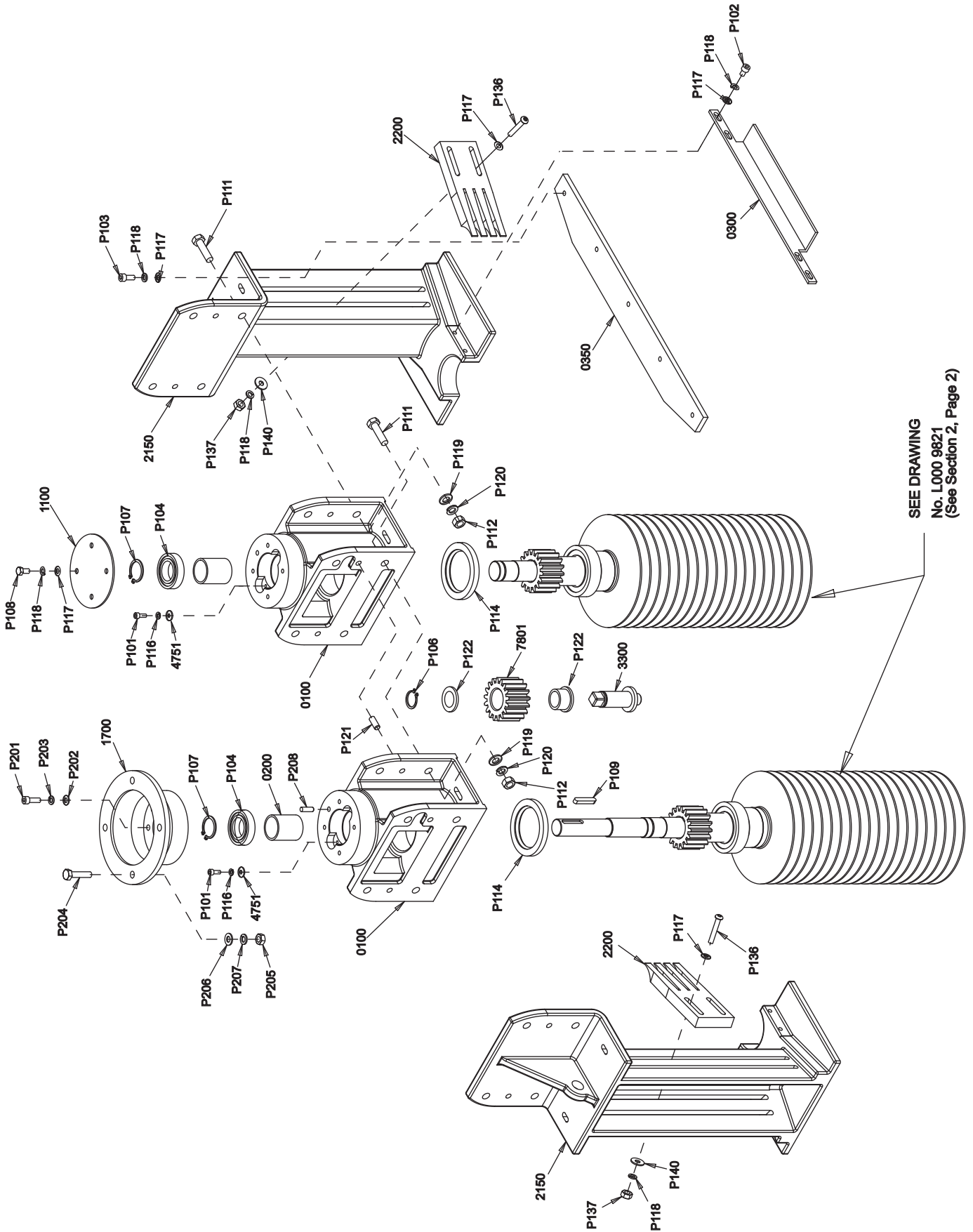

SEE DRAWING
No. L000 9821
(See Section 2, Page 2)

Part Numbers

200mm to 500mm THROAT PARTS

Item	Description	Code	Part No.
0100	Main Body	CD	L000 0100
0200	Top Datum Tube	MT	L000 0200
0201	Bottom Datum Tube	MT	L000 0201
0300	Bottom Baffle Plate	SF	L0-- 0305
0350	Top Baffle Plate	SF	L0-- 0350
0600	Name Plate	AA	D000 0600
1100	Top Cover Plate	MB	L000 1100
1200	Shaft End Cap	SF	L000 1200
1700	Adaptor Stool	CD	L000 170-
0512	Siderail	FC	551200-L
2200	Plastic Comb Bar	PR	L000 22--
2500	Plastic Disc	PP	L000 250-
3200	Drive Shaft	LF	L-00 3200
3250	Driven Shaft	LF	L-00 3250
3300	Idler Shaft	MJ	L000 3300
3500	Datum Spacer	SR	L000 350-
3600	Collar Stack	SB	L000 3600
4750	Bearing Lock Washer	SB	L000 4751
7800	Drive Gear	MQ	L000 7800
7801	Idler Gear	MQ	L000 7801
P101	M6x16 Hex. Socket Cap Screw	-	A112162F
P102	M8x12 Hex. Socket Cap Screw	-	A113122F
P103	M8x25 Hex. Socket Cap Screw	-	A113222F
P104	35x62x14 Single Row Deep Groove Ball Bearing	-	A150352B
P105	40x90x23 Single Row Deep Groove Ball Bearing	-	A170402B
P106	28mm Heavy Duty External Circlip	-	C104280P
P107	35mm Heavy Duty External Circlip	-	C104350P
P108	M8x16 Hex. Head Screw	-	F113160F
P109	8x7x45 Long Rectangular Parallel Key	-	K100845P
P110	10x7x45 Long Rectangular Parallel Key	-	K101045P
P111	M12x55 Hex. Head Bolt	-	K115310F
P112	M12 Hex. Nut	-	N115100F
P113	No. 0 x 3/16" Drive Screw	-	R101080F
P114	70x100x10 Rotary Shaft Lipseal	-	S361705P
P116	M6 Single Coil Spring Washer	-	W112251F
P117	M8 Plain Washer	-	W113051F
P118	M8 Single Coil Spring Washer	-	W113251F
P119	M12 Plain Washer	-	W115051F
P120	M12 Single Coil Spring Washer	-	W115251F
P121	10x25 Long Grade 1 Dowel	-	P152222P
P122	28x36x25 Oilite Bush	-	40918
P123	'O' Ring 40mm	-	S303910P
P133	M20x35 Hex. Head Screw	-	F119282F
P134	M20 Plain Washer	-	W119051F

Item	Description	Code	Part No.
P135	M20 Single Coil Spring Washer	-	W119251F
P136	M8x50 Hex. Socket Button Head Screw	-	H113302F
P137	M8 Hex. Nut	-	N113100F
P140	M8 Form G Washer	-	W113151F
P201	M8x25 Hex. Socket Cap Screw	-	A113222F
P202	M8 Plain Washer	-	W113051F
P203	M8 Single Coil Spring Washer	-	W113251F
P204	M10 or M12x35 Hex. Head Screw	-	F114260/F115260F
P205	M10 or M12 Hex. Nut	-	N114100F/N115100F
P206	M10 or M12 Plain Washer	-	W114051F/W115051F
P207	M10 or M12 Single Coil Spring Washer	-	W114251F/W115251F
P208	8x25 Long Grade 1 Dowel	-	P151222P
P219	O Ring	-	S343240P
P301	O Ring	-	S336340P
P302	Lipseal	-	S369454P
P303	Circlip	-	C108680P

Discreen Shafts

200mm to 500mm Throat L Series Discreen Shafts - L000 9821

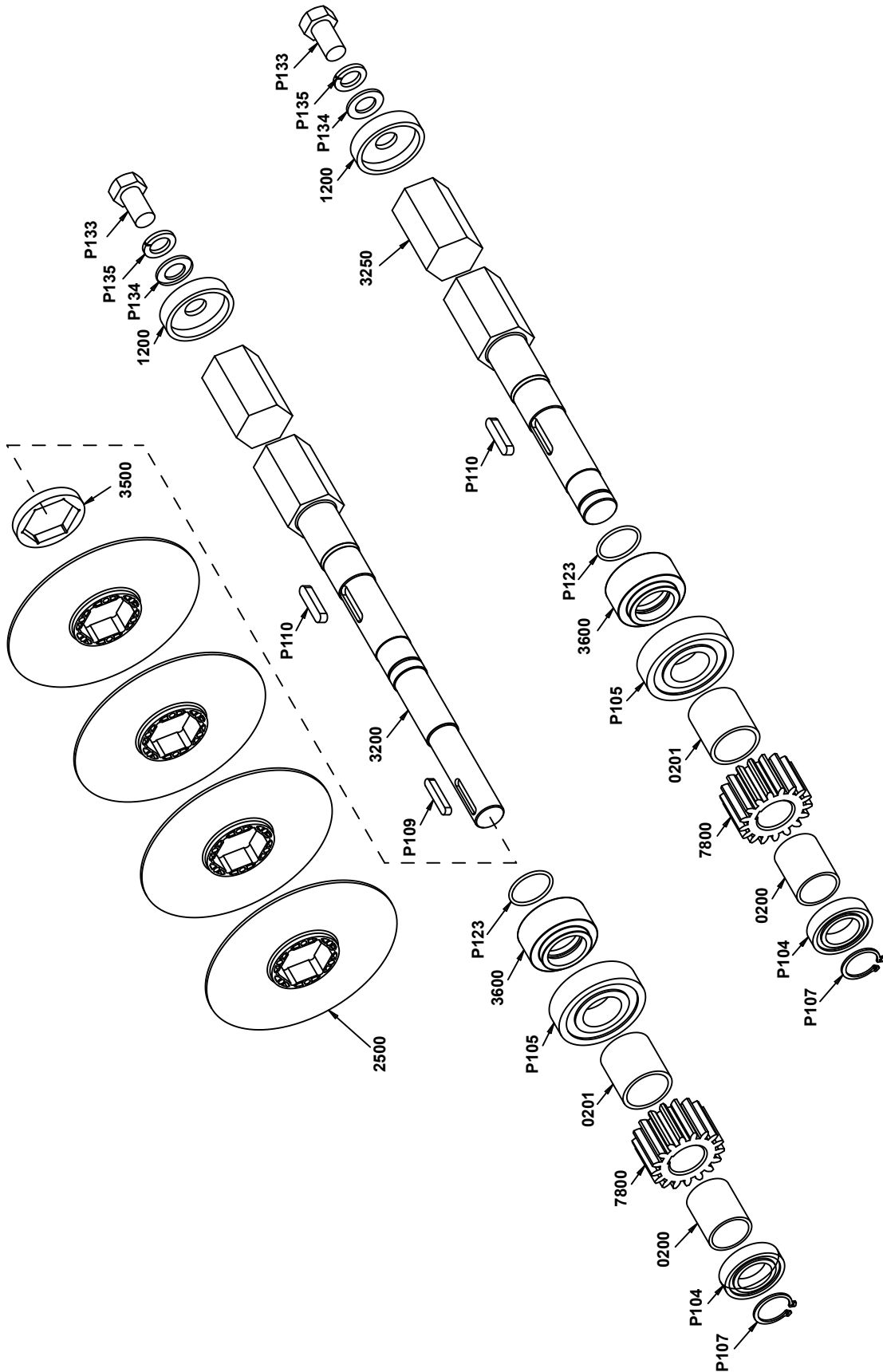

Part Numbers

L SERIES DISCREEN 750mm to 1750mm THROAT PARTS

Item	Description	Code	Part No.
0130	Top Housing	CD	L000 0132
0131	Bottom Housing	CD	L000 0131
0220	Idler Gear Bearing Spacer Inner	MD	L000 0220
0221	Idler Gear Bearing Spacer Outer	MD	L000 0221
0332	Bottom Baffle Plate Carrier	SF	L0-- 0332
0333	Bottom Baffle Plate	SF	L0-- 0333
0362	Top Baffle Plate	SF	L0-- 0362
0600	Nameplate	AA	D000 0600
1120	Top Cover Plate	SF	L000 1121
1101	Bottom Cover Plate	SF	L000 1101
1720	Adaptor Stool	CD	L000 172-
0612	Siderail	SO	L000 2160
2190	Siderail Mounting Bkt. - top left	CF	L000 2192
2191	Siderail Mounting Bkt. - top right	CF	L000 2191
2172	Siderail Mounting Bkt. - bottom left	CD	L000 2172
2173	Siderail Mounting Bkt. - bottom right	CD	L000 2173
2200	Plastic Comb Bar	PR	L000 22--
2500	Plastic Disc	PP	L000 25--
2200	Stainless Steel Comb Bar	ST	D000 22--
2500	Stainless Steel Disc	SD	D000 25--
3220	Drive Shaft - 1.1/1.5kW	LF	L--- 3226
3230	Drive Shaft - 2.2/3.0kW	LF	L--- 3236
3235	Driven Shaft	LF	L--- 3235
3300	Idler Shaft	MJ	L000 3330
3500	Datum Spacer	SR	L000 35--
3630	Top Stack Collar	SB	L000 3630
7835	Drive Gear	MI	L000 7835
7831	Idler Gear	MQ	L000 7831
P103	M8x25 Hex. Socket Cap Screw	-	A113222F
P104	45x85x19 Single Row Deep Groove Ball Bearing	-	A100852B
P105	45x85x23 Single Row Roller Bearing	-	R160456B
P107	45mm Heavy Duty External Circlip	-	C101450P
P108	M8x16 Hex Head Screw	-	F113161F
P109	14x9x70 Rectangular Parallel Key	-	K101470P
P110	10x8x66 Rectangular Parallel Key	-	K111066P
P111	M12x55 Hex. Head Bolt	-	K115310F
P112	M12 Hex Nut	-	N115100F
P113	No. 0 x 3/16" Drive Screw	-	R101080F
P114	70x95x10 Shaft Lipseal	-	S361703P
P115	1/8" BSP Grease Nipple	-	L120032P
P117	M8 Plain Washer	-	W113051F
P118	M8 Single Coil Spring Washer	-	W113251F
P119	M12 Plain Washer	-	W115051F
P120	M12 Single Coil Spring Washer	-	W115251F
P121	10x25 Long Grade 1 Dowel	-	P152222F
P123	47mm O Ring	-	P079303S

Item	Description	Code	Part No.
P136	M8x50 Hex. Socket Button Head Screw	-	H113320F
P137	M8 Hex. Nut	-	N113100F
P140	M8 Large Washer (Form G)	-	W113151F
P141	M10 x 35 Hex. Head Screw	-	F114260F
P142	M10 Single Coil Spring Washer	-	W114251F
P143	M10 Plain Washer	-	W114051F
P144	70x100x10 Shaft Lipseal	-	S361705P
P147	M36 Hex. Thin Nut	-	N825452F
P201	M8x25 High Tensile Hex. Socket Cap Screw	-	A113221F
P202	M8 Plain Washer	-	W113051F
P203	M8 Single Coil Spring Washer	-	W113251F
P204	M10 or M12x45 Hex. Head Screw	-	K114290F / K115290F
P205	M10 or M12 Hex Nut	-	N114100F / N115100F
P206	M10 or M12 Plain Washer	-	W114051F / W115051F
P207	M10 or M12 Single Coil Spring Washer	-	W114251F / W115251F
P208	10x35 Long Grade 1 Dowel	-	P152262F
P209	70x90x10 Shaft Lipseal	-	S361704P
P210	Internal Circlip 85mm x 3mm	-	C102780P
P211	Roller Bearing 70x47x30	-	U100470B
P212	Mech Seal / Bearing Cartridge	-	M040155G
P213	45x65x8 Shaft Lipseal	-	S352456P
P214	M6x16 Button Head Screw	-	H112161F
P215	M6 Form G Penny Washer	-	W112151F
P216	1/2" BSP Oil Level Sensor	-	LBFS 111.0
P217	1/2" BSP Window Nut	-	W408047
P218	1/2" BSP Mal. Iron Taper Plug	-	P100432S
P219	1/4" Dowty Seal	-	W408078
P220	Cable	-	ESG34AH2000

Discreen Shafts

750mm to 1750mm L Series Discreen Shafts - L000 9831

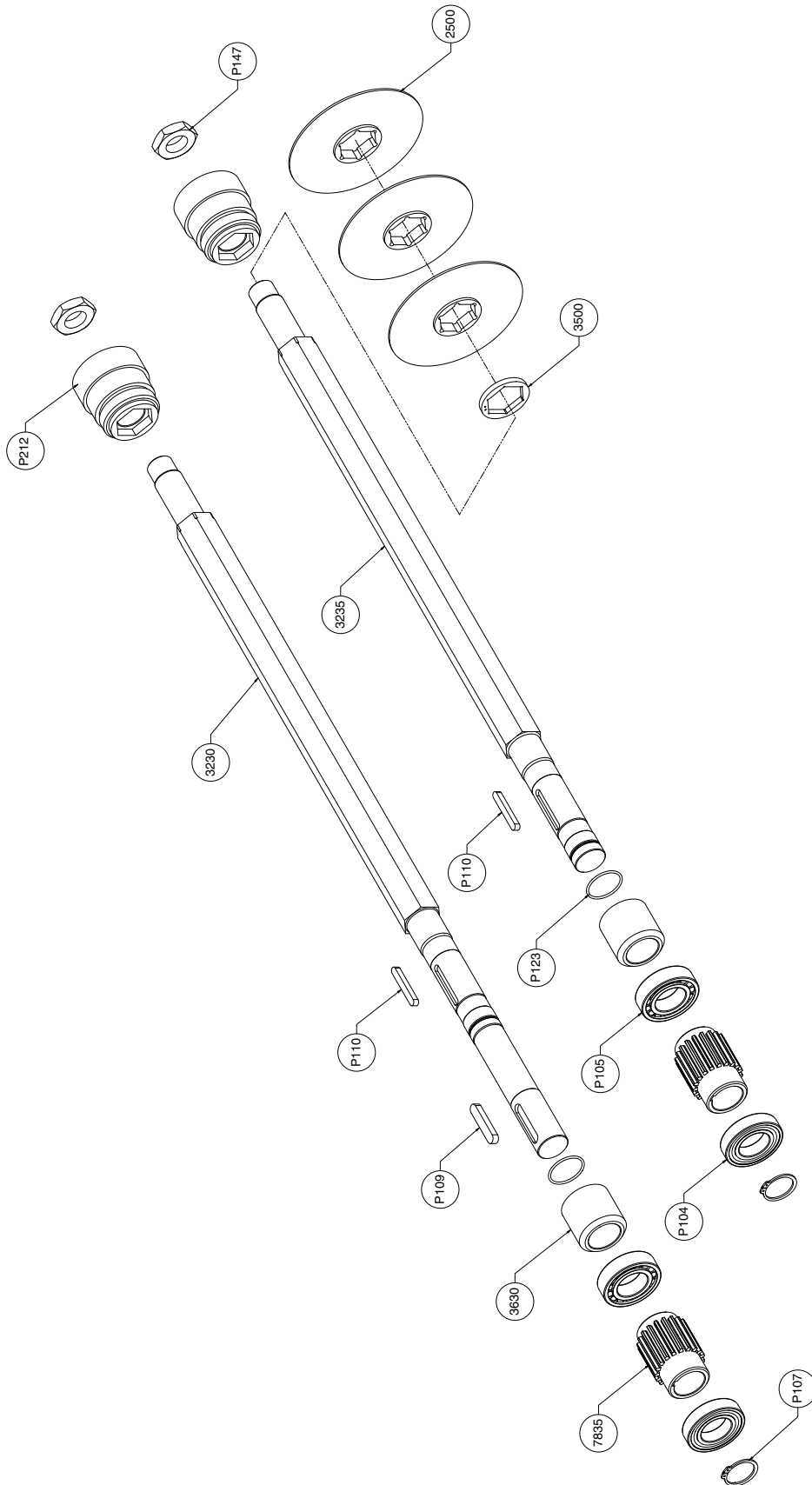

Sectional Arrangement

750mm to 1750mm Throats - L000 9810

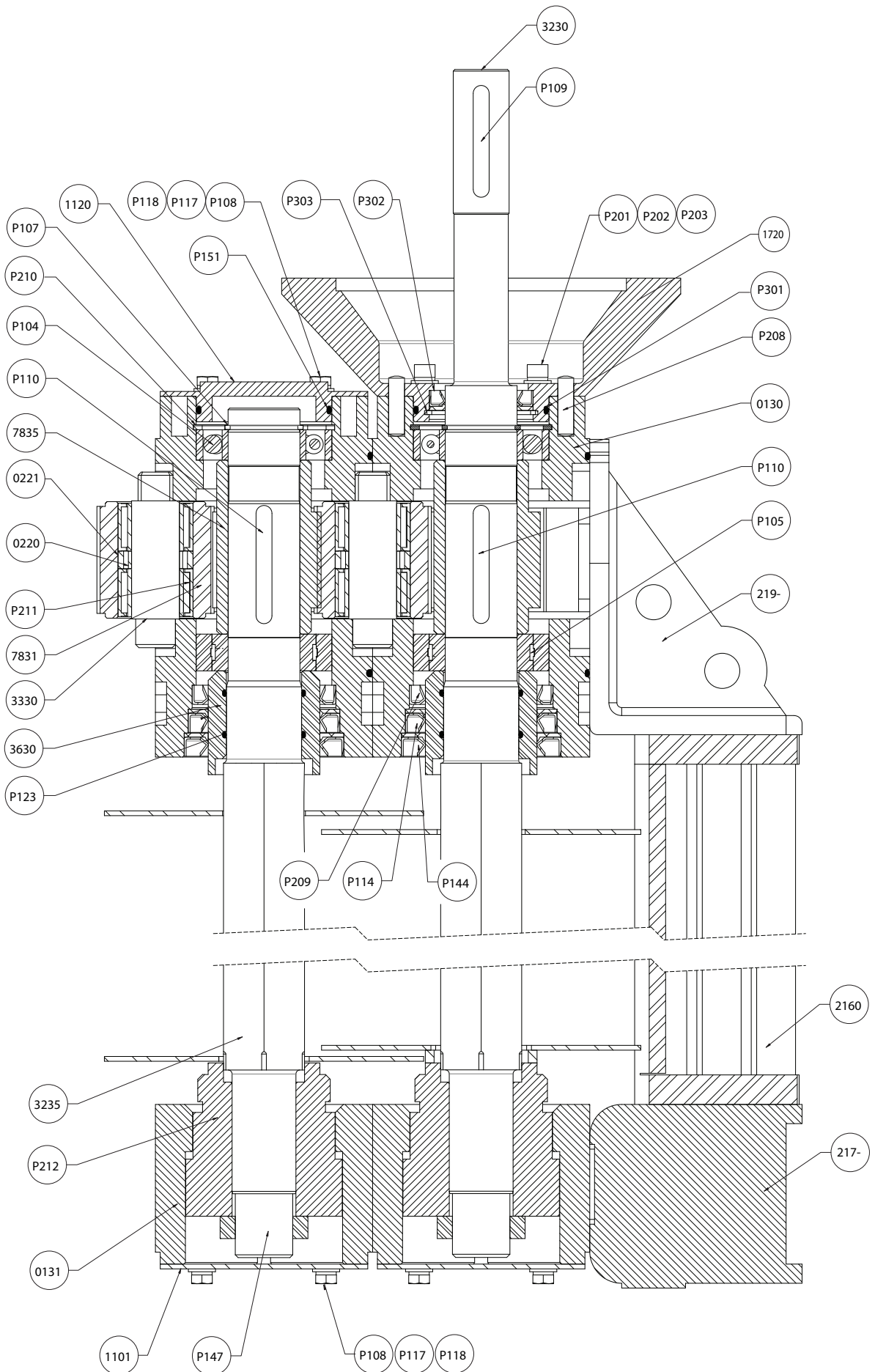

Scheduled Maintenance

9.0 L SERIES DISCREEN: SCHEDULED MAINTENANCE

Reference Drawing Numbers:

L000 9820, L000 9821, L000 9830, L000 9831

Caution: When servicing the L Series Discreen or motor controller, be certain the main line breaker is open and tagged. Serious injury could result from accidental start up. Disconnect and tag motor leads in motor terminal box.

200mm to 500mm THROAT L SERIES DISCREENS

BEARING AND SEAL INSPECTION

Every 12 months bearings and seals should be inspected.

- (1) Remove the L Series Discreen from the installation using lifting gear provided.
- (2) Steam clean the L Series Discreen. Do not steam clean the motor or gear drive.

TOP BEARINGS AND SEALS

- (1) Remove screws P204 from adaptor stool and extract gear drive unit.
- (2) Remove screws P127 and extract adaptor stool from main body.
- (3) Remove screws P108 from top cover plates. Remove top cover plates 1100 and Dowel P132.
- (4) Remove screws P102 from bottom baffle plate. Remove bottom baffle plate 0300.
- (5) Remove screws P103 from top baffle plate. Remove top baffle plate 0350.
- (6) Remove screws P103 from siderails. Remove siderails 2150 complete with comb bars 2200.
- (7) Remove circlips P107 from shafts. Extract shafts 3250 through main body.

- (8) Inspect main body 0100 for signs of leakage or contaminants, if any are found bearings and/or lipseals are worn and must be replaced.
- (9) Remove datum tube top 0200, datum tube bottom 0201, drive gear 7800, key P110, and stack collar 3600 from shafts.
- (10) Inspect 'O' Ring P138 for wear and replace if necessary.
- (11) If no leakage or contaminants are found the bearings and seals do not need to be replaced.
- (12) Loosen off fastener P133 and re-assemble the L Series Discreen in reverse order tightening P133 after shafts have been fitted into the bearing housing.
- (13) Reinstall the L Series Discreen. Reconnect motor leads. Verify that the motor leads are connected for proper voltage and start L Series Discreen. Check for correct disc rotation.

750mm to 1750 THROAT L SERIES DISCREEN

BEARING AND SEAL INSPECTION

Every 12 months the bearings and seals should be inspected.

- (1) Remove the L Series Discreen from the installation using the lifting gear provided.
- (2) Steam clean the L Series Discreen. Do not steam clean the motor or drive gear unless it is suitably rated.

BOTTOM BEARINGS AND SEALS

- (1) Remove the screws P108 from the bottom cover plates 1101 and remove cover plates.
- (2) Inspect the bottom housing bore for evidence of leakage or contaminants.

Lubrication Schedule

Note: A small amount of moisture, due to condensation, is normal and does not indicate bearing or seal failure.

- (2) If greater amounts of fluid are present the bearings and/or seals are worn and should be replaced. Refer to the following instructions for the dismantling and re-assembly procedure.
- (3) If the bearings and seals appear to be in good order refit the bottom cover plates after cleaning and sealing the mating faces with Loctite 5910 or equivalent.

TOP BEARINGS AND SEALS

- (1) Remove the screws P108 from the top cover plates 1100 and remove cover plates.
- (2) Remove screws P204 from adaptor stool 1700 and extract the drive unit.
- (3) Remove the screws P201 from the adaptor stool 1700 and extract the adaptor stool.
- (4) Inspect the top housing bore for evidence of leakage or contaminants. Note: A small amount of moisture, due to condensation, is normal and does not indicate bearing or seal failure.
- (5) If greater amounts of fluid are present the bearings and/or seals are worn and should be replaced. Refer to the following instructions for the dismantling and re-assembly procedure.
- (6) If the bearings and seals appear to be in good order refit the top cover plates, adaptor stool and drive unit after cleaning and sealing the mating faces with Loctite 574 or equivalent.

LUBRICATION SCHEDULE

Routine replenishment of the drive train lubrication is not necessary. If, during bearing and seal inspection, excessive moisture is present the cause should be investigated and rectified and the bearing housings re-filled with the specified lubricants.

750-1750mm throat machines are fitted with an oil level sensor which will stop the Discreen if the oil level falls too low.

On 750-1750 throat machines an oil level sight glass is fitted. This should be half full at all times.

RECOMMENDED LUBRICANTS

Top Bearing Housing:

200-500 Throat: BP Energrease LC2 750-1750 Throat: Klubersynth GH6-460

Lip Seals:

Rocol Foodlube Universal 2

REPLACEMENT OF GEARED MOTOR UNIT

WARNING:

When servicing the L Series Discreen or motor controller, be certain the main line breaker is open and tagged. Serious injury could result from accidental start up.

- (1) L Series Discreen may be left installed. Disconnect and tag main lines in breaker upstream of controller.
- (2) Disconnect and tag motor leads in motor terminal box.
- (3) Remove fasteners P204, lift geared motor unit off L Series Discreen.
- (4) Replace new or repaired drive unit on L Series Discreen and secure with fasteners P128, P129, P130 and P131.
- (5) Reconnect motor leads. Verify that the motor leads are connected for proper voltage and start L Series Discreen. Check for correct disc rotation.

NOTE:

WHEN CHECKING FOR CORRECT DISC ROTATION ALWAYS ENSURE THAT PERSONNEL ARE WELL CLEAR OF DISCS.

Dismantling and Assembly Procedure

L SERIES DISCREEN – DISMANTLING AND ASSEMBLY PROCEDURE

For dismantling procedure see pages 4 to 12.

Before dismantling the Discreen note the position of the geared motor. On re-assembly it should be re-fitted in the same position.

Re-assembly is the reverse of dismantling.

For critical tightening torques and sealing requirements see pages 13 to 16.

Dismantling Diagrams

L SERIES DISCREEN - 200mm to 500mm THROAT

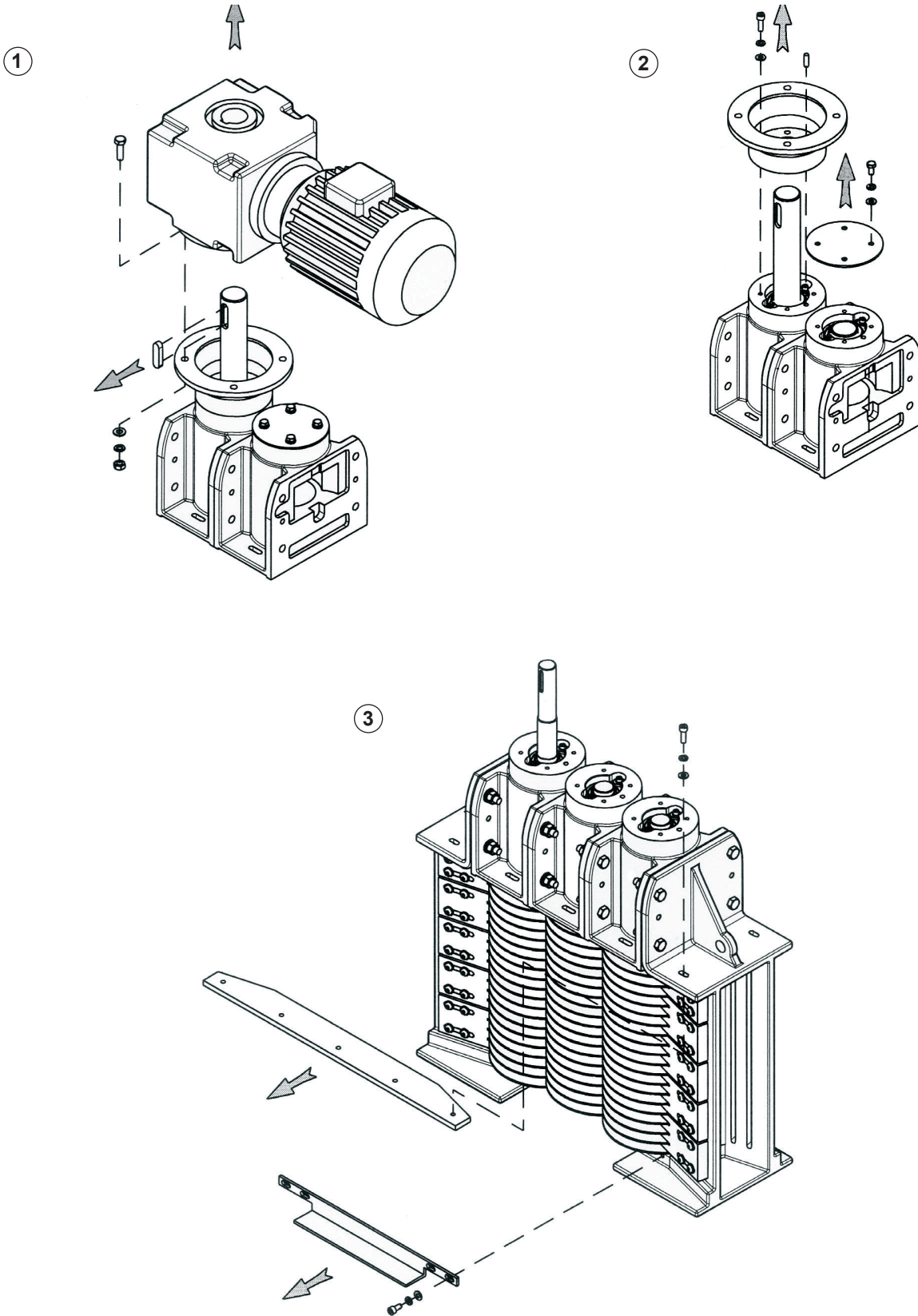

L SERIES DISCREEN - 200mm to 500mm THROAT

4

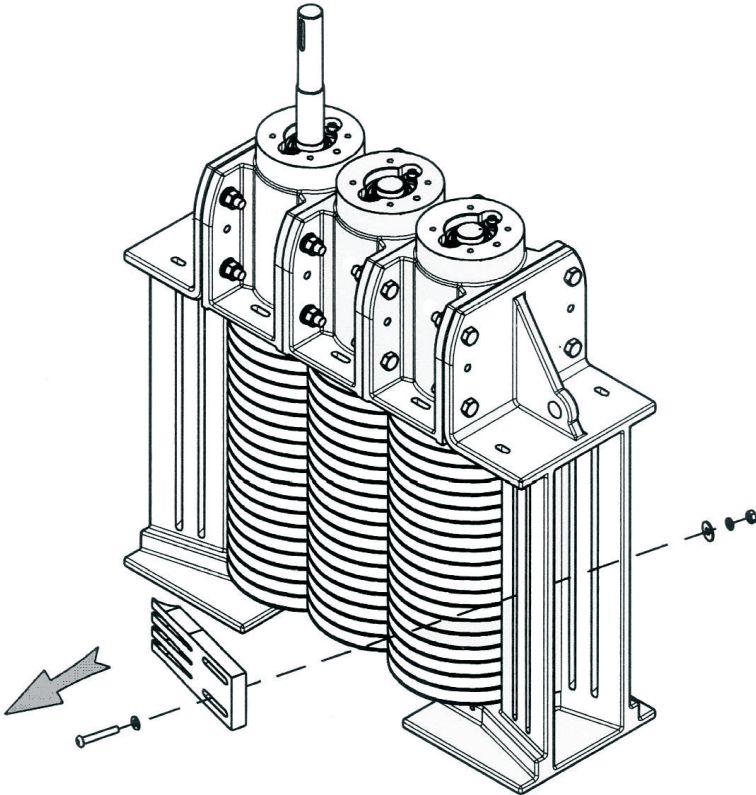

5

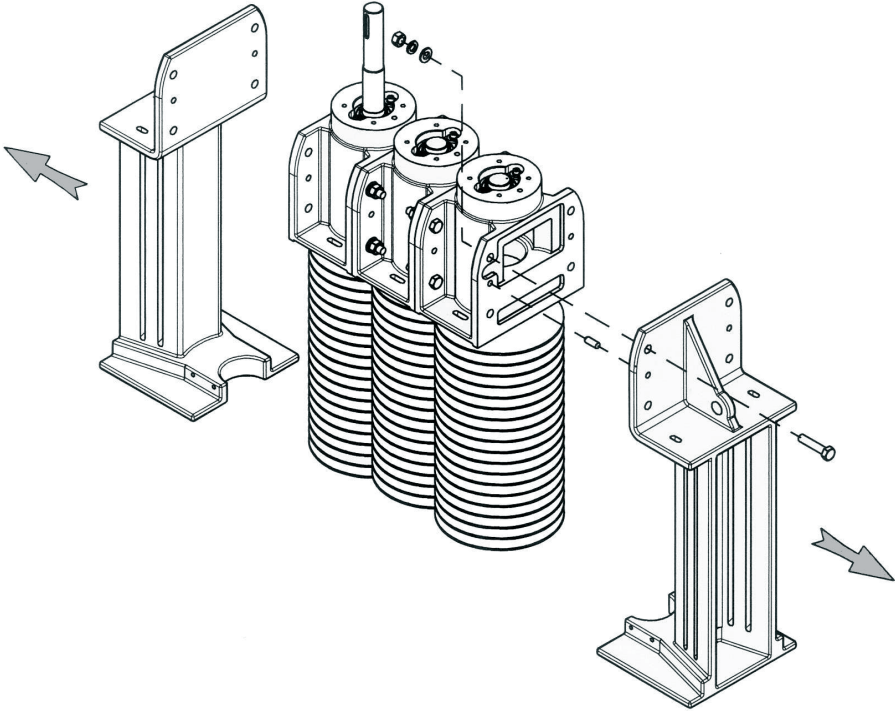

L SERIES DISCREEN - 200mm to 500mm THROAT

6

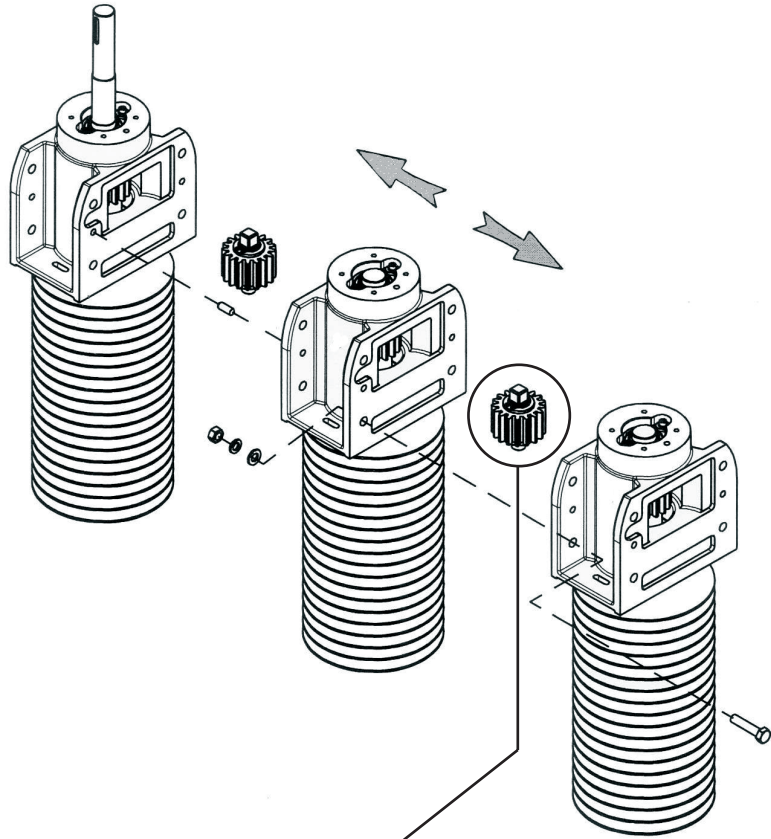

7

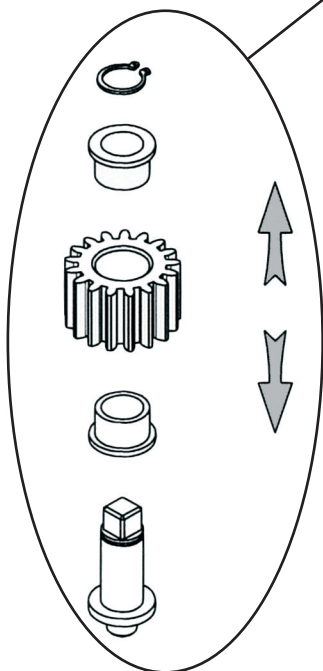

8

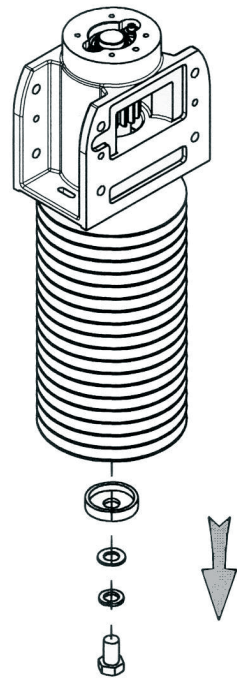

L SERIES DISCREEN - 200mm to 500mm THROAT

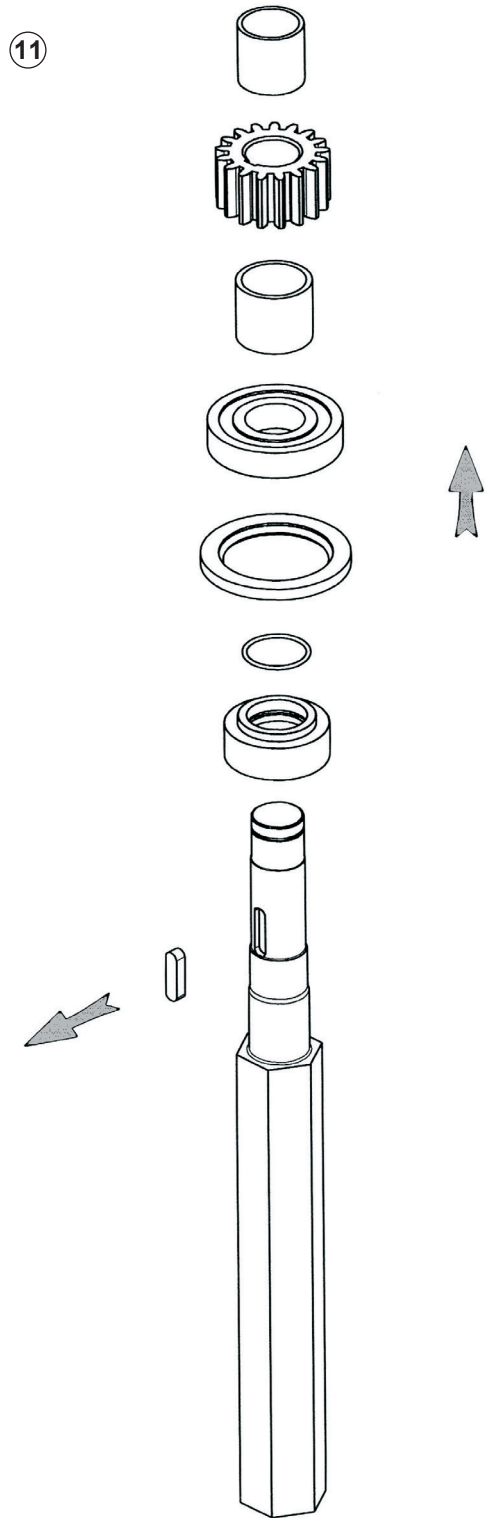
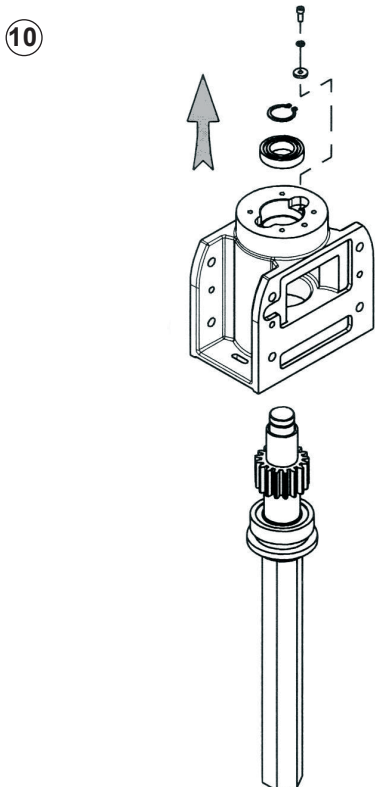
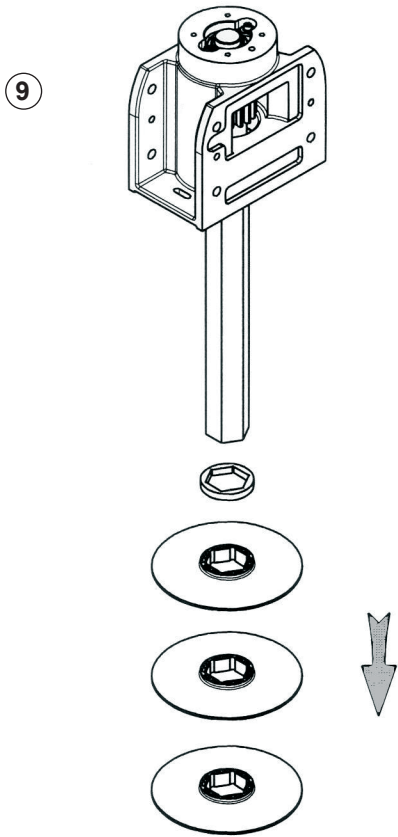

Dismantling Diagrams

L SERIES DISCREEN - 750mm to 1750mm THROAT

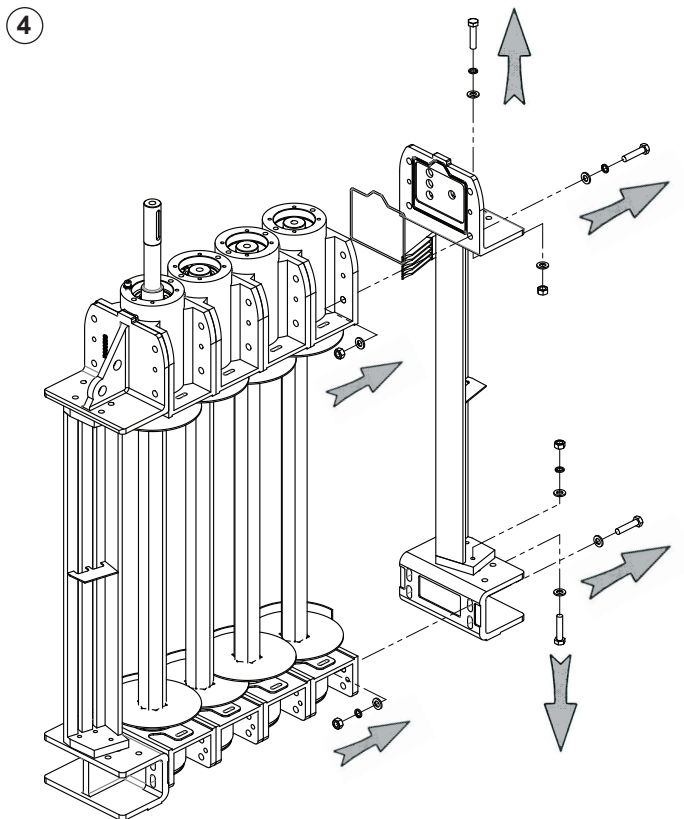
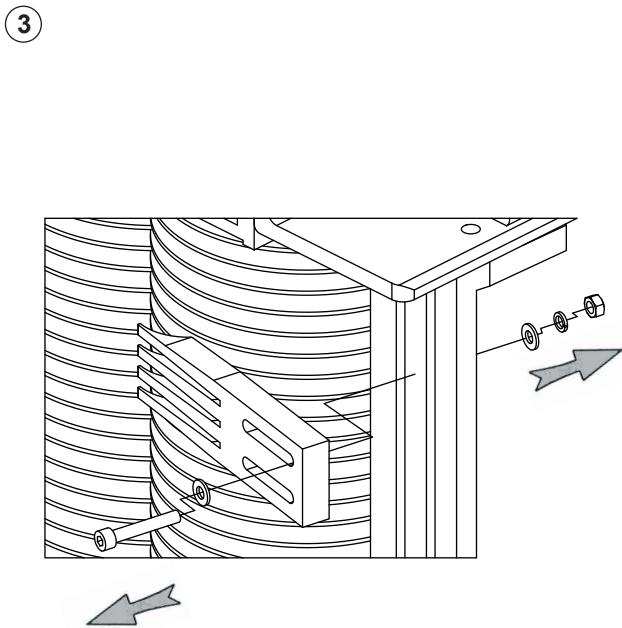
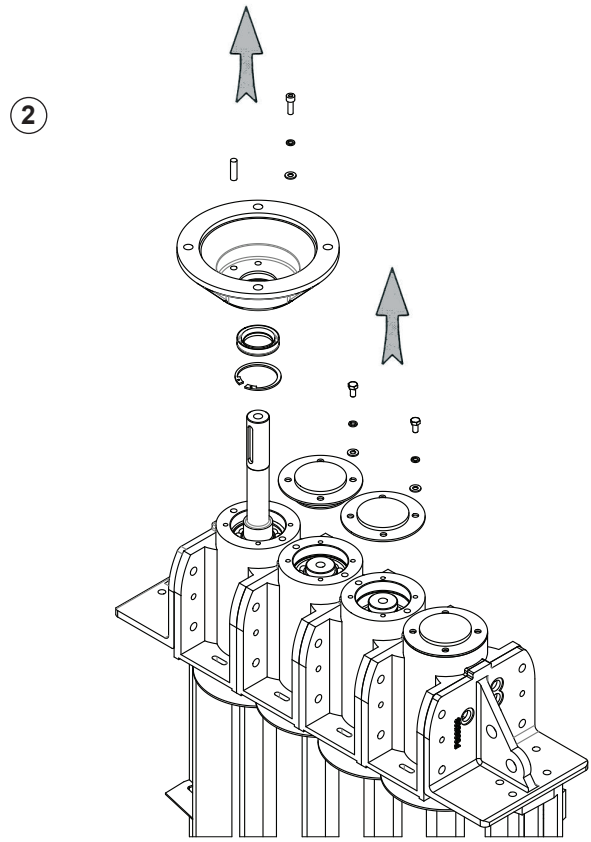
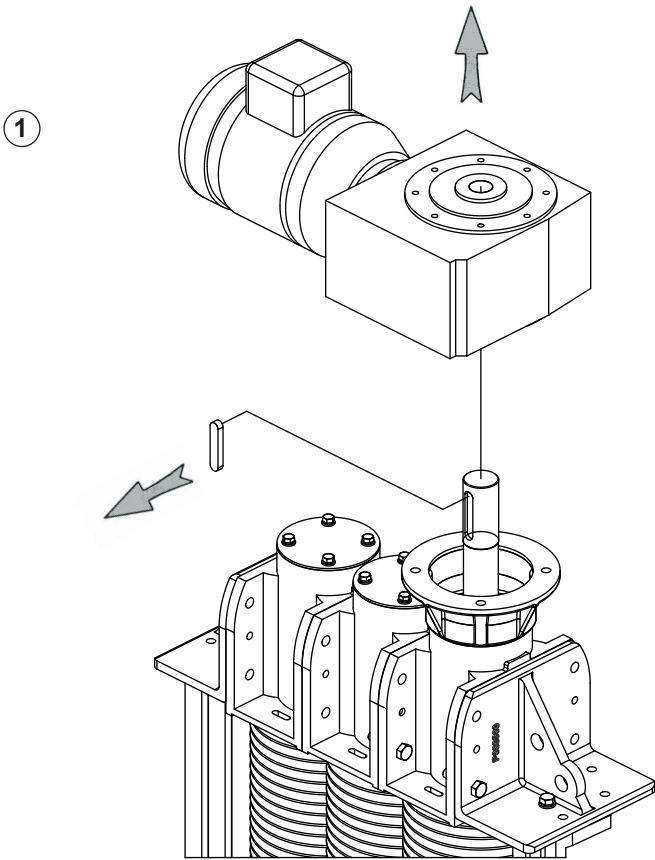

L SERIES DISCREEN - 750mm to 1750mm THROAT

5

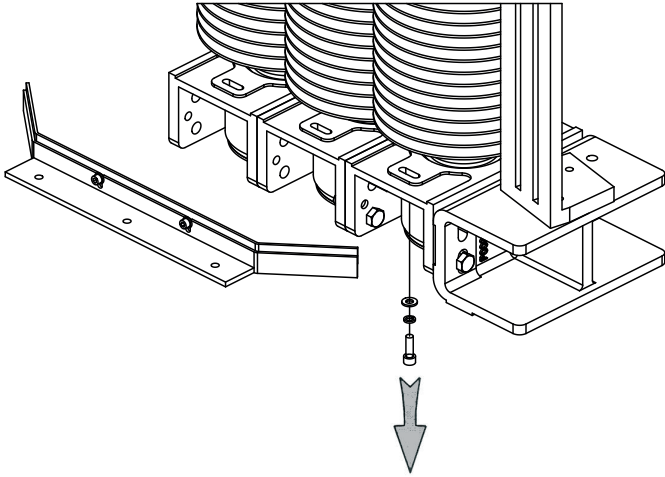

6

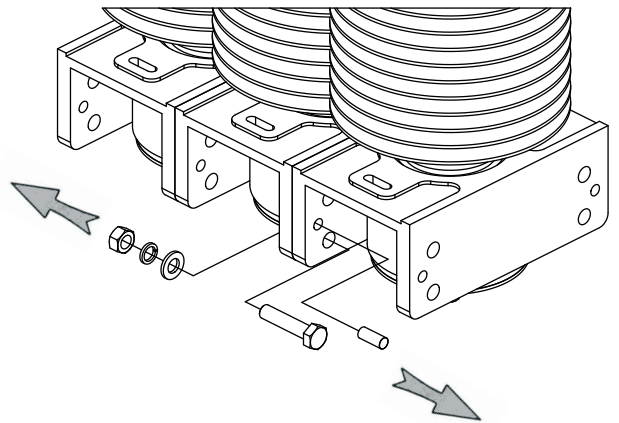

7

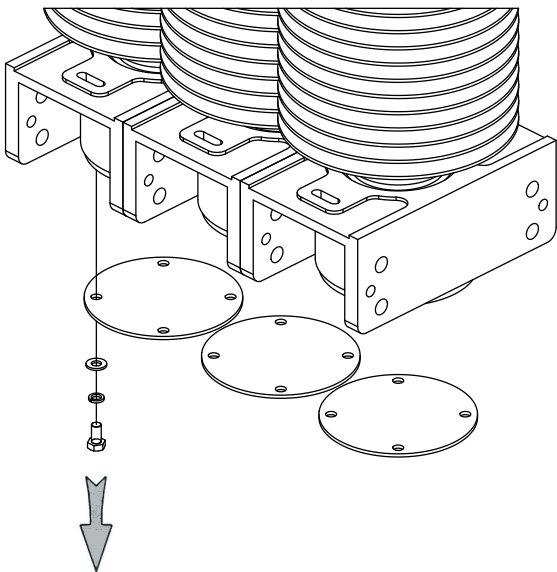

8

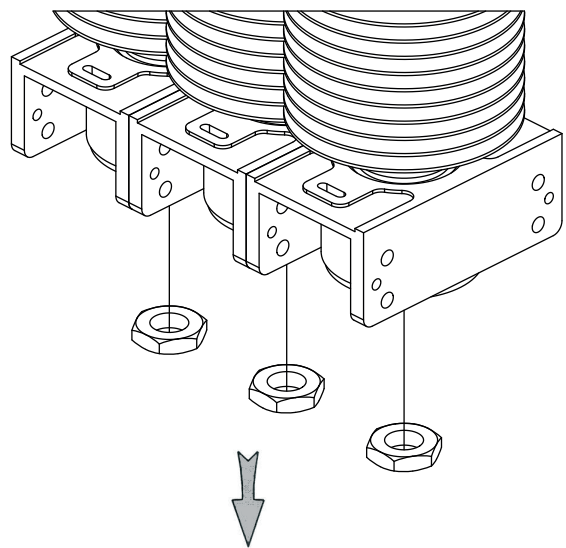

L SERIES DISCREEN - 750mm to 1750mm THROAT

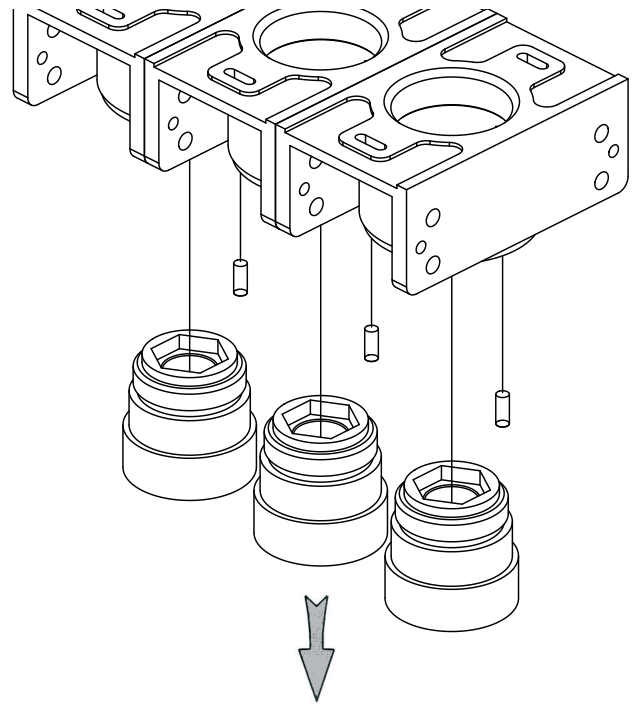
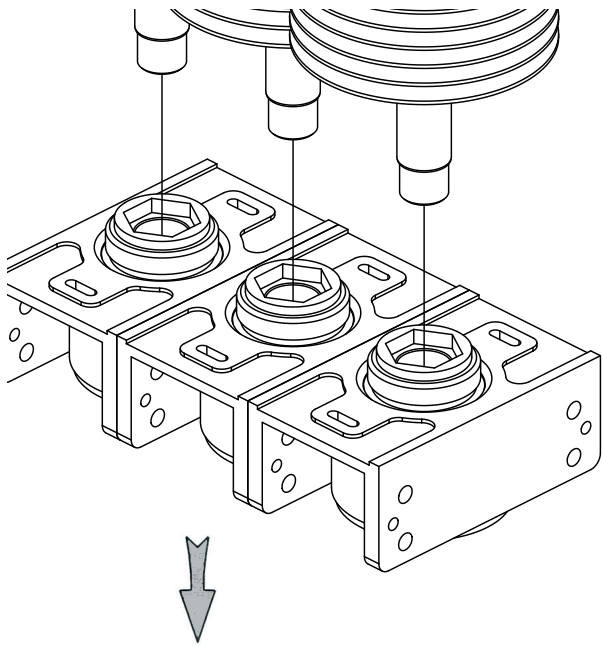

11

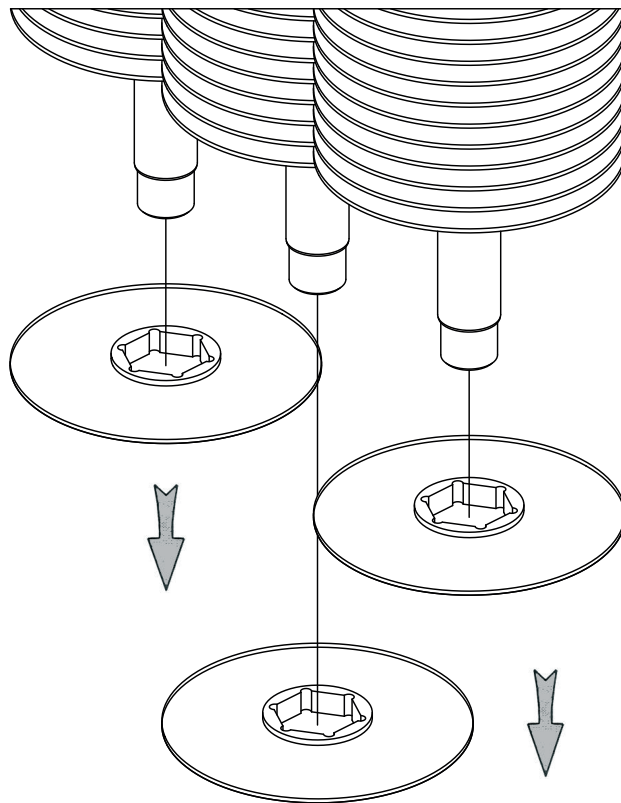

L SERIES DISCREEN - 750mm to 1750mm THROAT

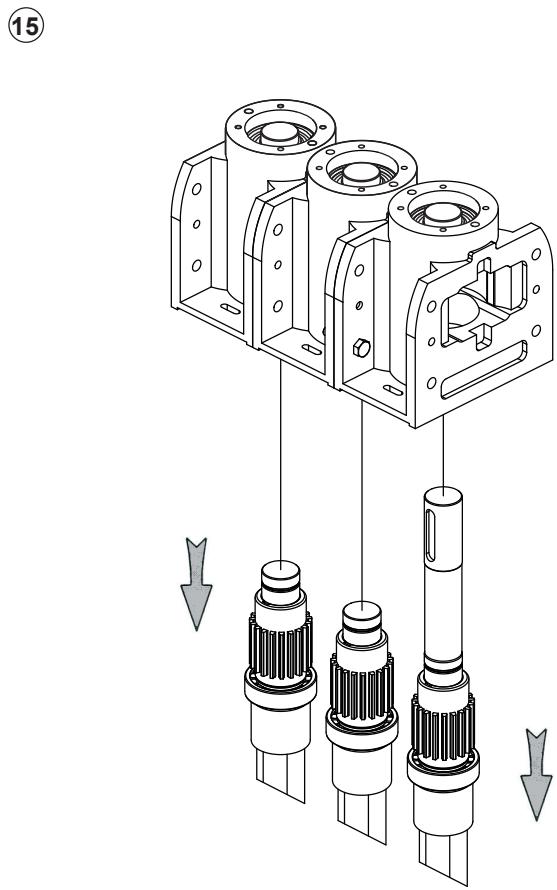
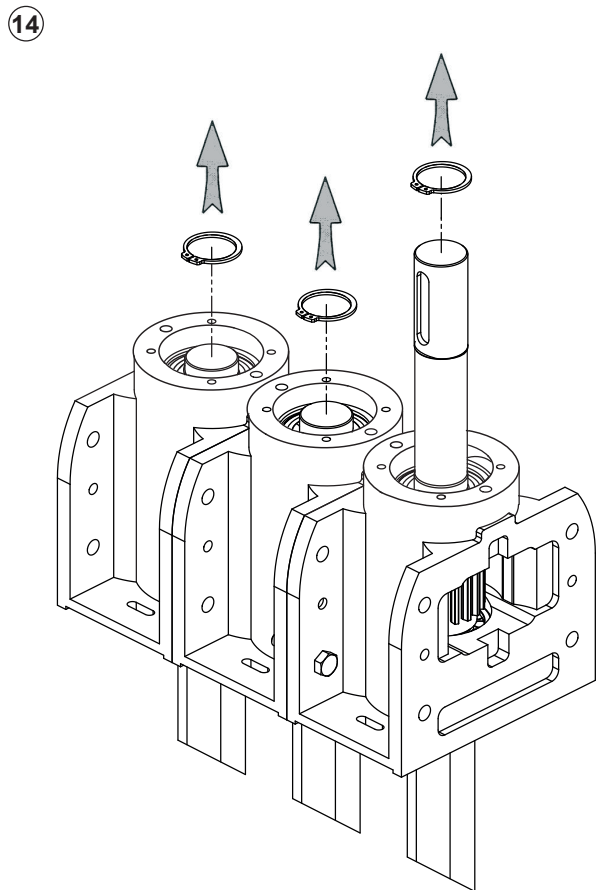
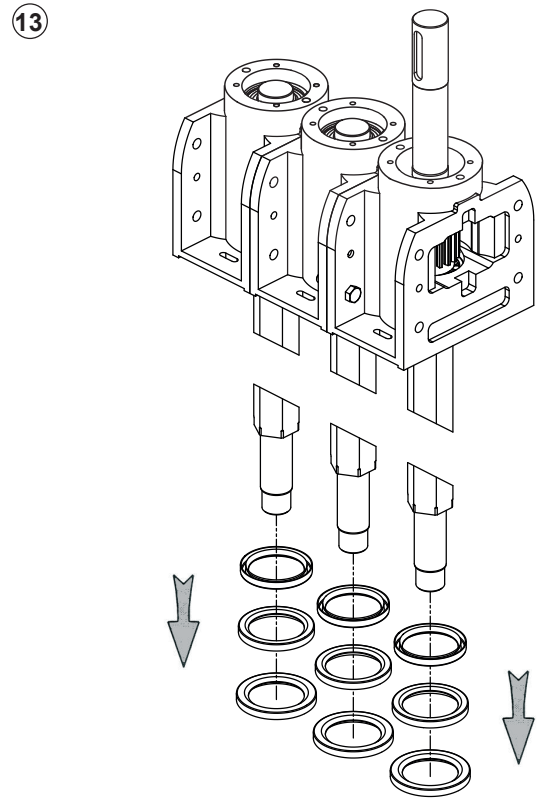
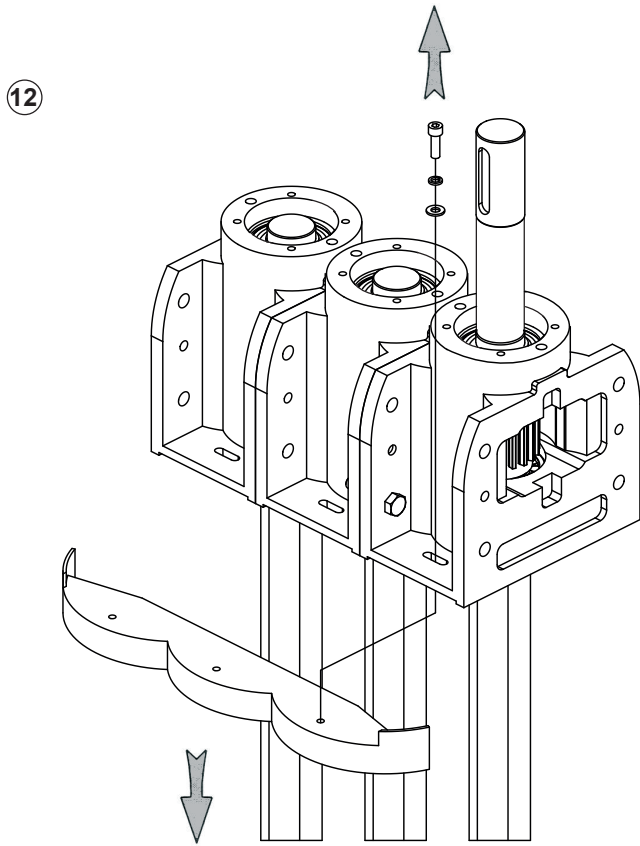

L SERIES DISCREEN - 750mm to 1750mm THROAT

16

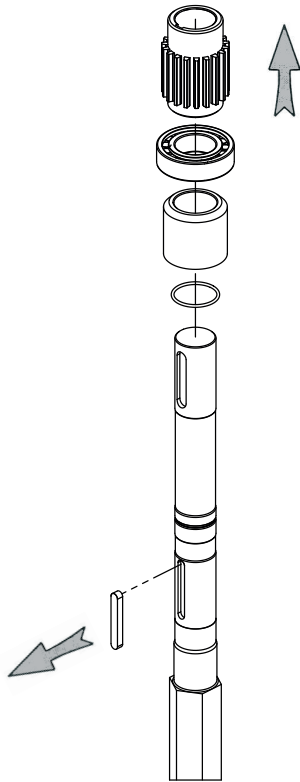

17

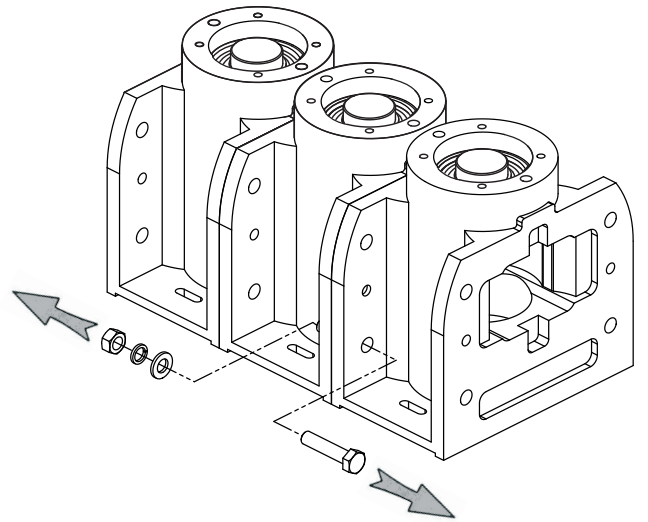

18

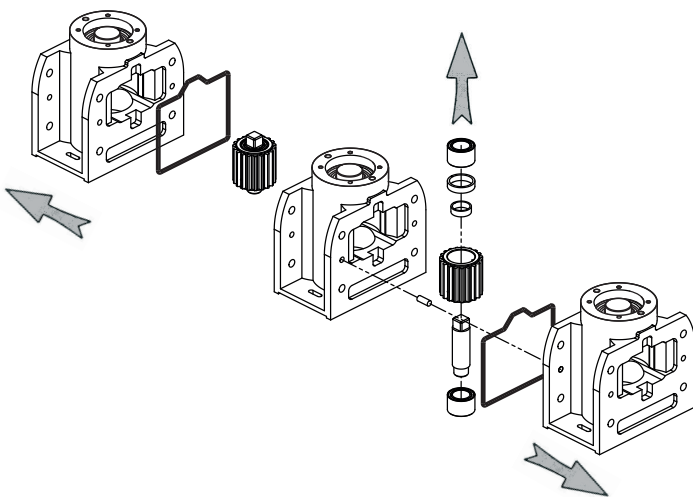

19

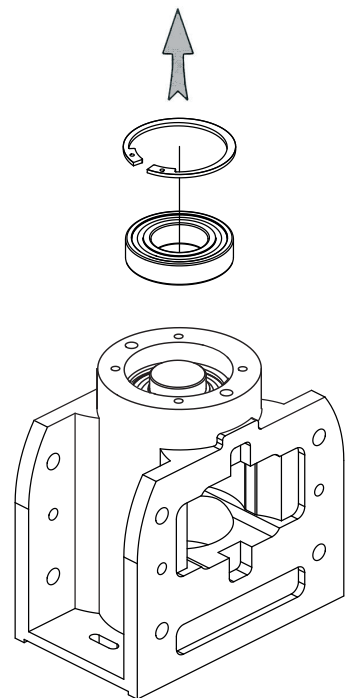

L SERIES DISCREEN
750mm to 1750mm Throats Only

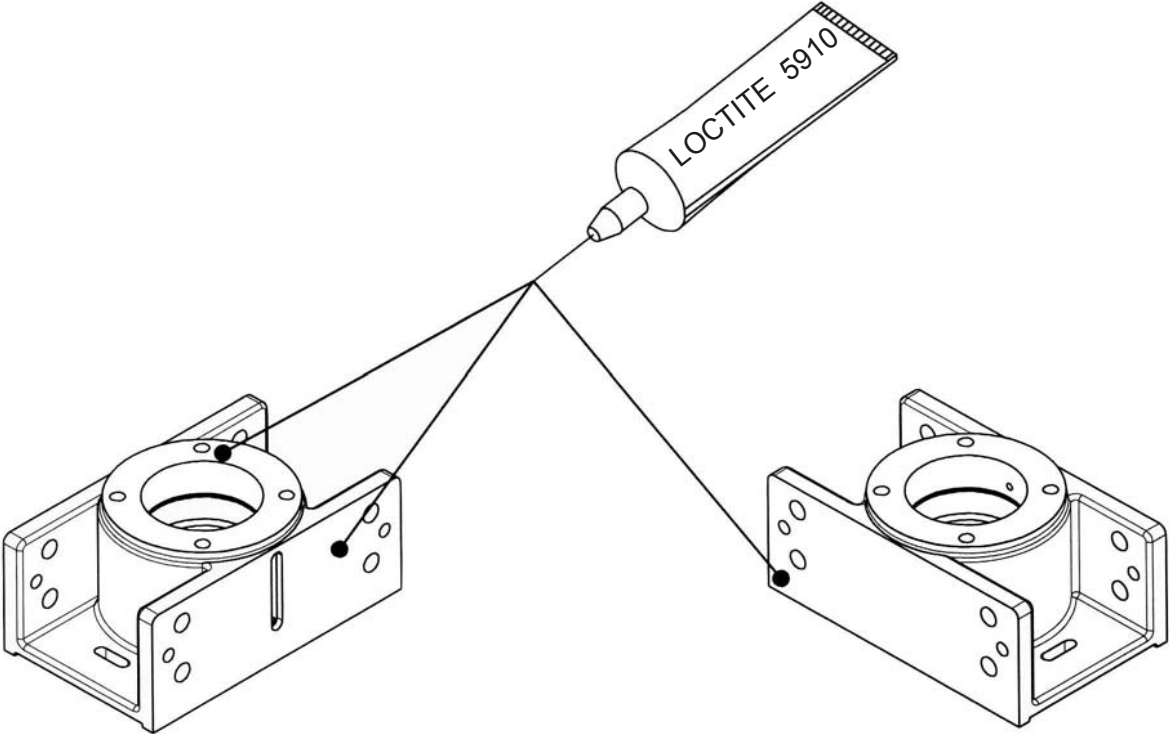

Loctite Details

L SERIES DISCREEN All Throat Sizes

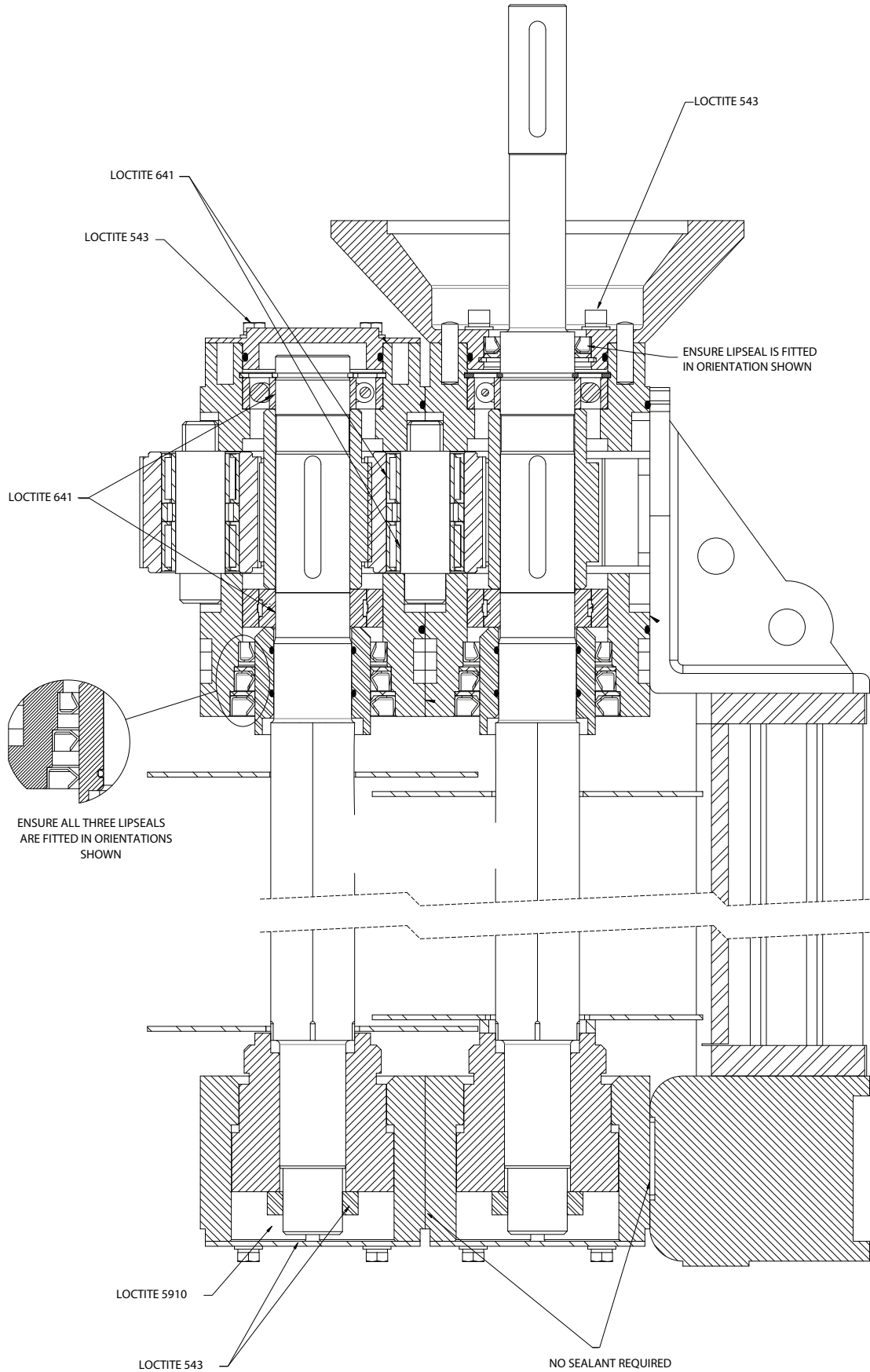

Oil Filled Machine Hardware Detail

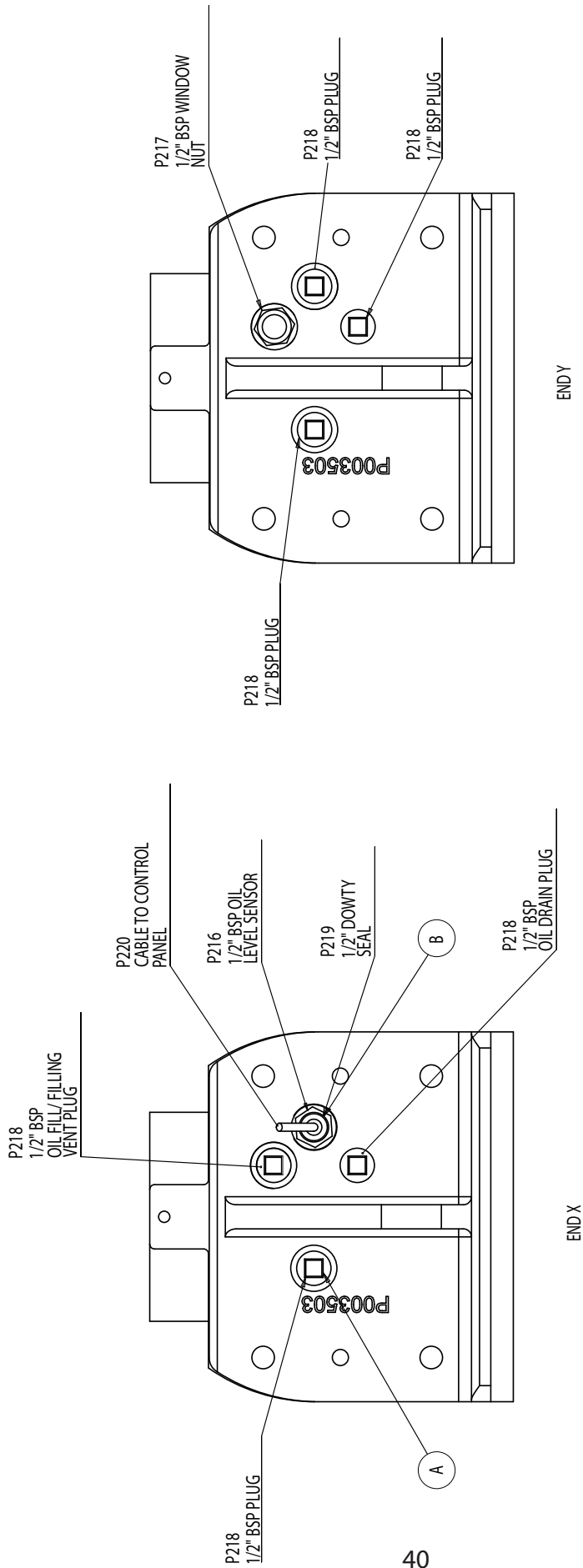

- NOTE:
1. WINDOW NUT IS FITTED AT OPPOSITE END OF UPPER BEARING HOUSING ASSEMBLY FROM OIL LEVEL SENSOR.
 2. SENSOR TO BE FITTED AT POSITION A OR B ON UPPER BEARING HOUSING OF MACHINE TO AVOID INTERFERENCE WHEN LIFTING THE ASSEMBLY.
 3. IF OIL LEVEL SENSOR, P216 IS IN POSITION A, PLUG POSITION B WITH P218.
 4. STANDARD OIL LEVEL SENSOR, CABLE LENGTH OF 20M TO CONTROL PANEL, CABLE MUST BE SECURELY AND RIDGELY TO MACHINE WHEREVER POSSIBLE.
 - 5.
 6. LENGTHS OF UNSUPPORTED CABLE MUST BE KEPT TO A MINIMUM.

Assembly and Torque Settings

L SERIES DISCREEN All Throat Sizes

RE-ASSEMBLY

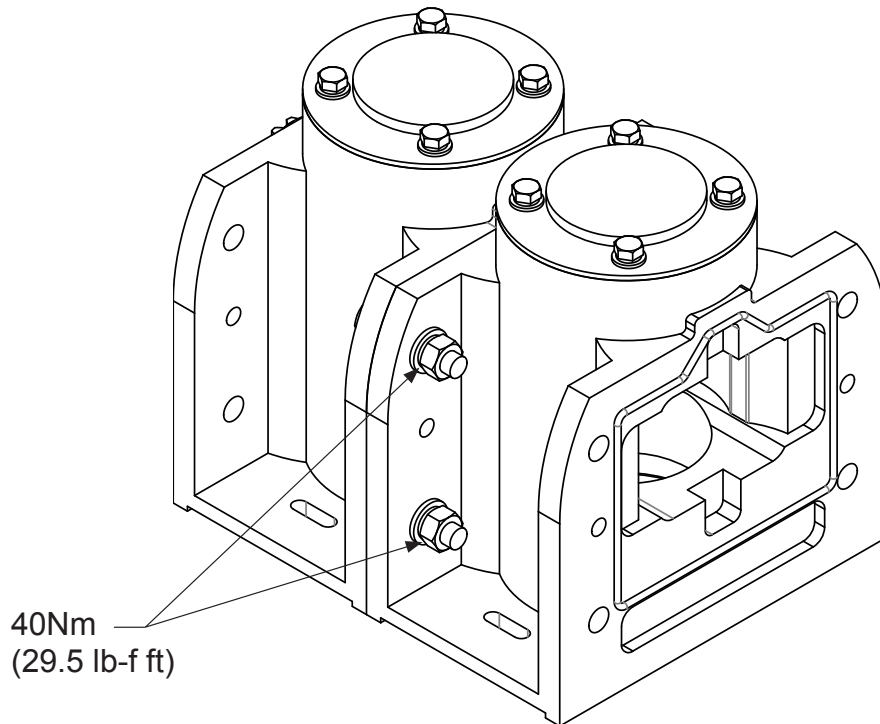

200mm to 500mm Throats Only

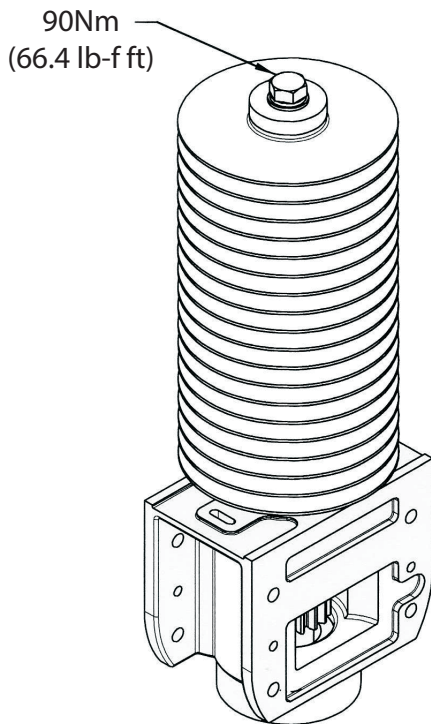

750mm to 1750mm Throats Only

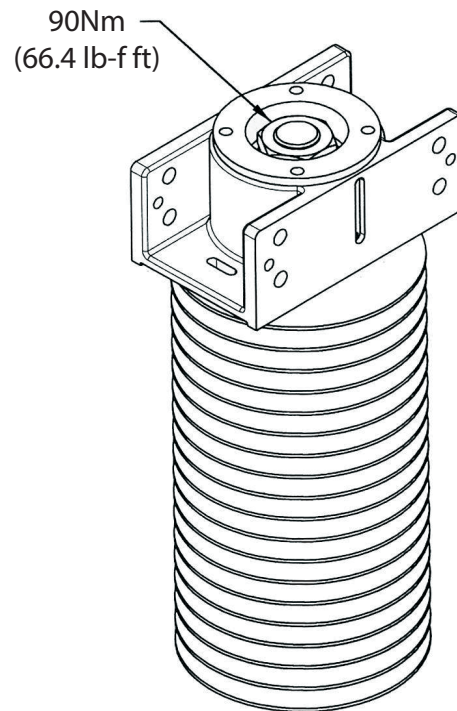

Standard Drive Positions

STANDARD DISCREEN DRIVE POSITIONS - IP55

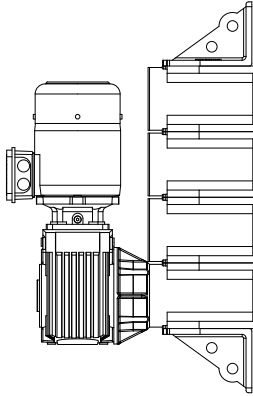
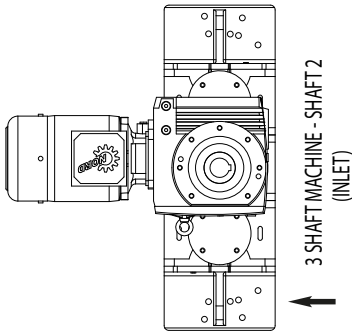

4 SHAFT MACHINE - SHAFT 1

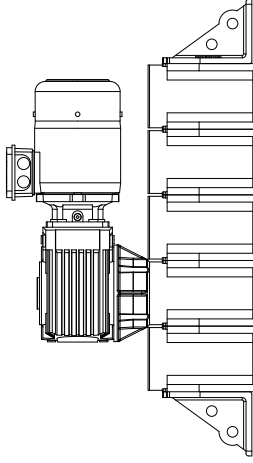

5 SHAFT MACHINE - SHAFT 2

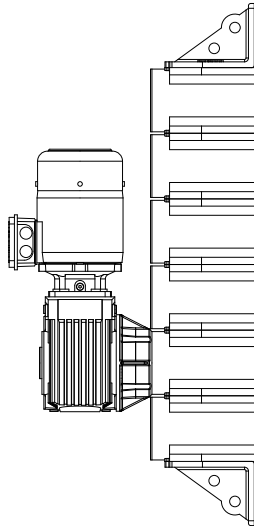

6 SHAFT MACHINE - SHAFT 2

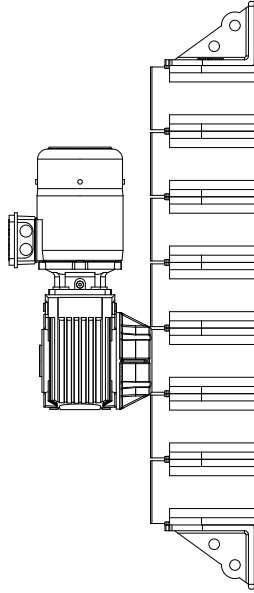

7 SHAFT MACHINE - SHAFT 3

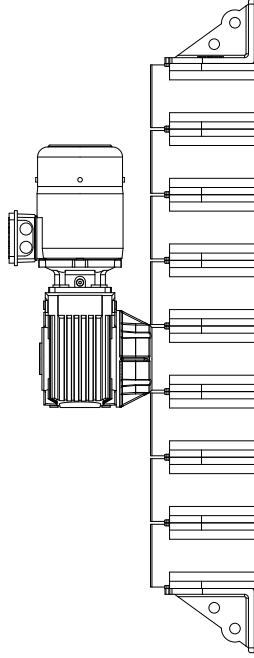

8 SHAFT MACHINE - SHAFT 4

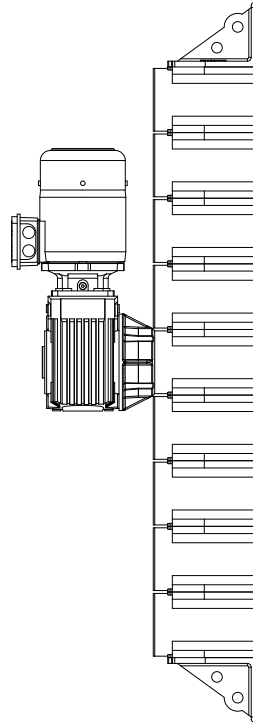

9 SHAFT MACHINE - SHAFT 5

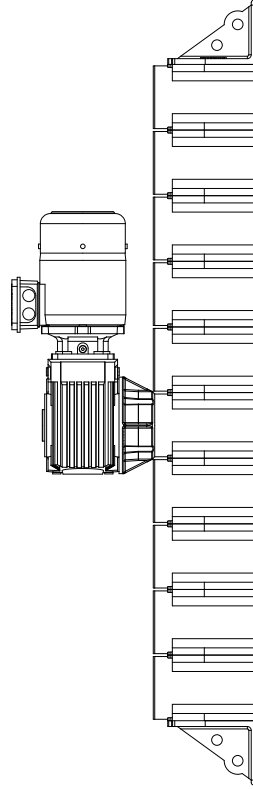

10 SHAFT MACHINE - SHAFT 5

RIGHT HAND MACHINE VIEWED FROM MACHINE INLET.
 LEFT HAND MACHINE TO BE BUILT ON OPPOSITE SHAFT WITH DRIVE TURNED THROUGH 90°
 (DRIVES SHOWN PERPENDICULAR TO BE BUILT ON THE SAME SHAFT).
 STORM MACHINES TO BE BUILT AS PER RIGHT HAND MACHINES (AS OF 04/2016)

STANDARD DISCREEN DRIVE POSITIONS - IP68

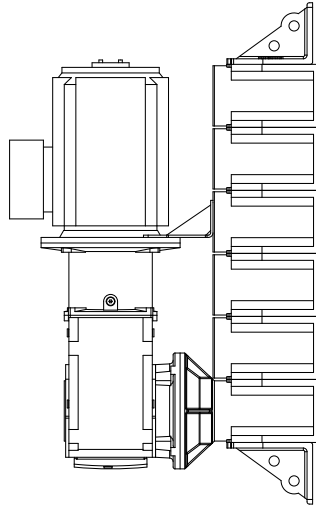
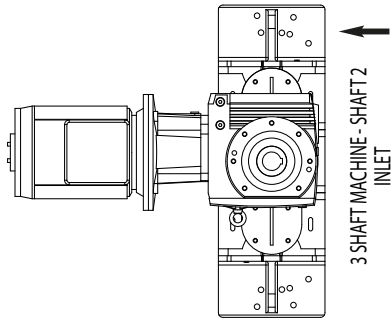

6 SHAFT MACHINE - SHAFT 1

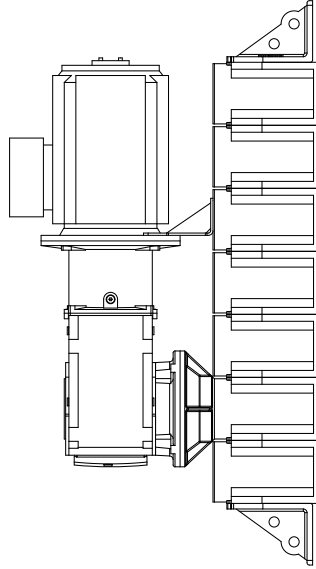
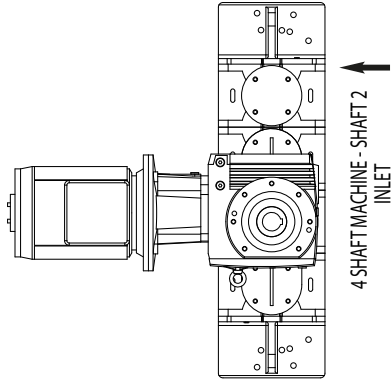

7 SHAFT MACHINE - SHAFT 2

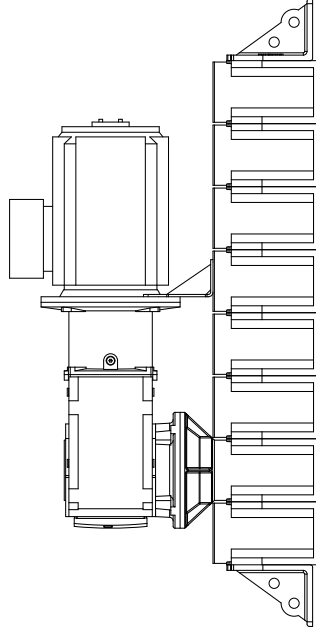
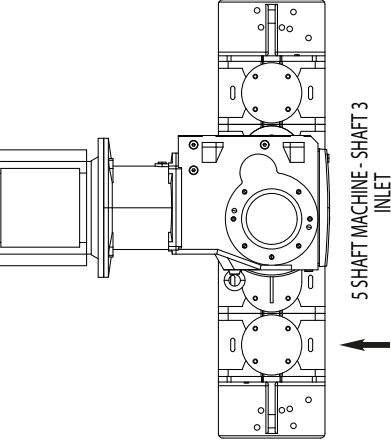

8 SHAFT MACHINE - SHAFT 2

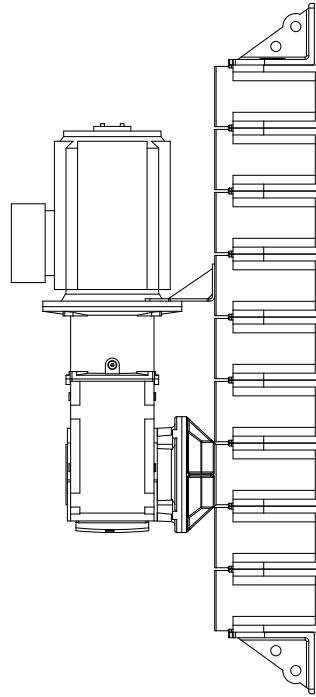

9 SHAFT MACHINE - SHAFT 3

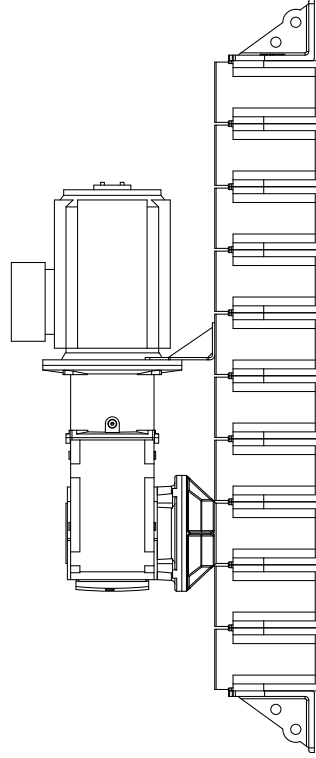

10 SHAFT MACHINE - SHAFT 3

RIGHT HAND MACHINE VIEWED FROM MACHINE INLET.
 LEFT HAND MACHINE TO BE BUILT ON OPPOSITE SHAFT WITH DRIVE TURNED THROUGH 90°
 (DRIVES SHOWN PERPENDICULAR TO BE BUILT ON THE SAME SHAFT).
 STORM MACHINES TO BE BUILT AS PER RIGHT HAND MACHINES (AS OF 04/2016)

Wiring Diagram

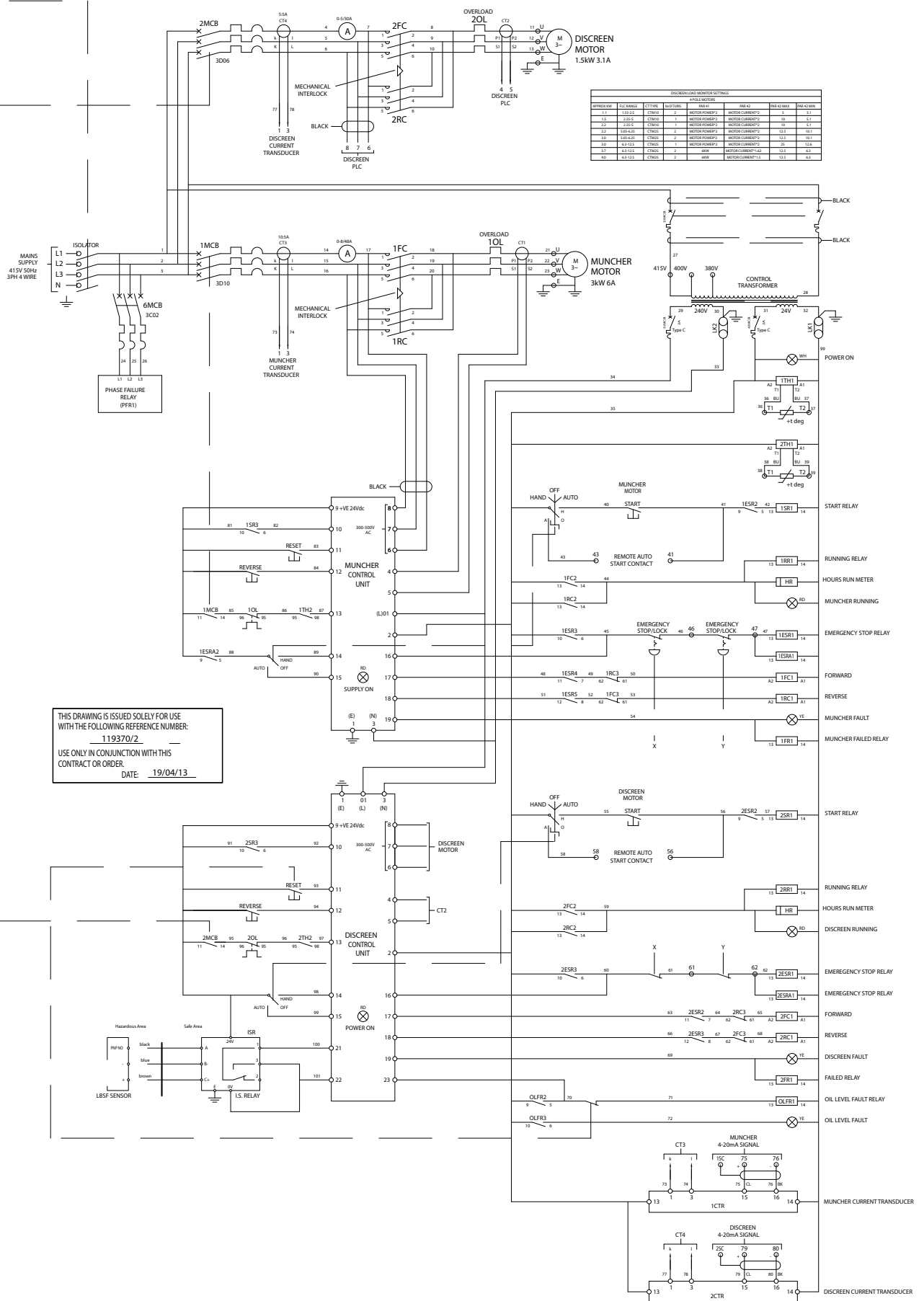

General Arrangement

L SERIES DISCREEN - 200mm to 500mm Throats - GA Dimensions - L000 9900

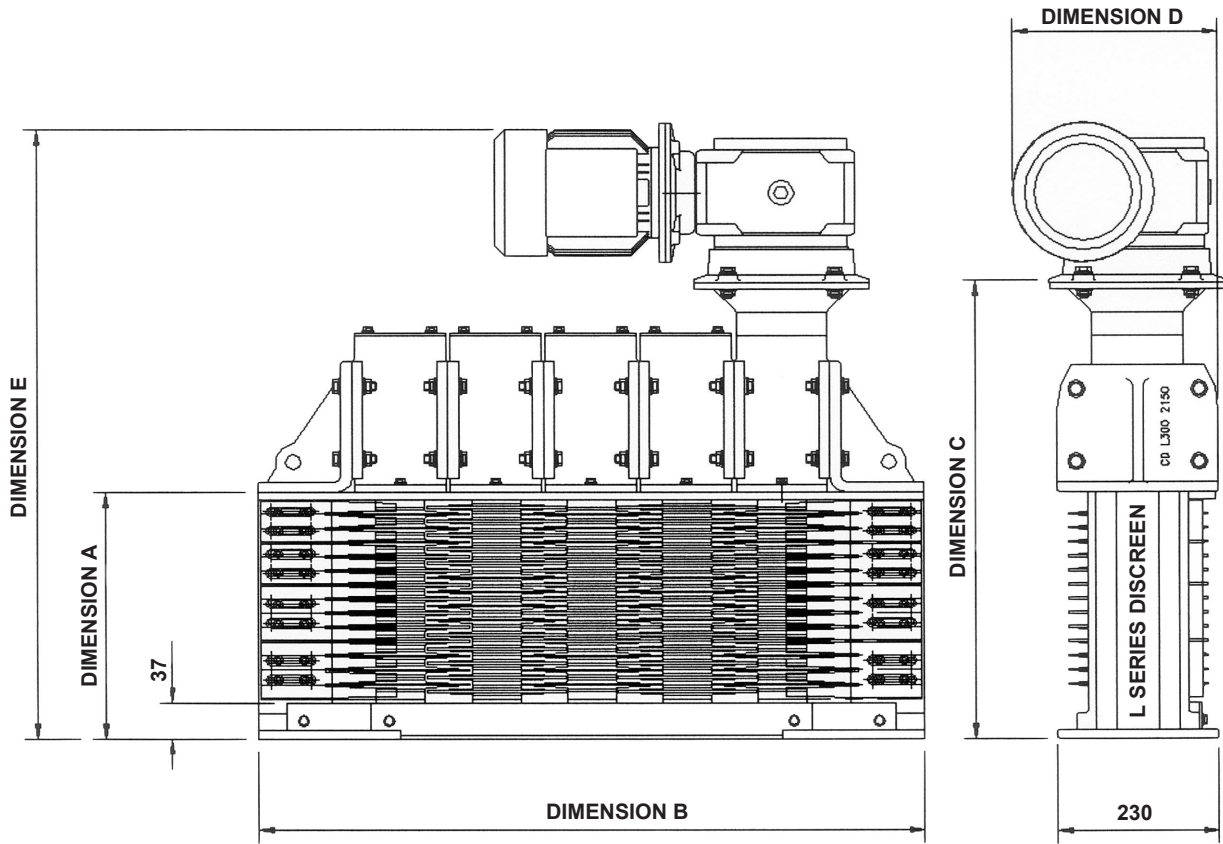

METRIC

MODEL	DIM A	DIM B	DIM C	DIMENSION D				DIMENSION E			
				0.75kW	1.1kW	1.5kW	2.2kW	0.75kW	1.1kW	1.5kW	2.2kW
CL510	558	1628	865	238	248	248	258	1030	1039	1065	1075
CL509		1492									
CL508		1356									
CL507		1220									
CL506		1084									
CL505		948									
CL504		812									
CL503		676									

MODEL	DIM A	DIM B	DIM C	DIMENSION D				DIMENSION E			
				0.75kW	1.1kW	1.5kW	2.2kW	0.75kW	1.1kW	1.5kW	2.2kW
CL310	358	1628	665	238	248	248	258	830	839	865	875
CL309		1492									
CL308		1356									
CL307		1220									
CL306		1084									
CL305		948									
CL304		812									
CL303		676									

MODEL	DIM A	DIM B	DIM C	DIMENSION D				DIMENSION E			
				0.75kW	1.1kW	1.5kW	2.2kW	0.75kW	1.1kW	1.5kW	2.2kW
CL410	458	1628	765	238	248	248	258	930	939	965	975
CL409		1492									
CL408		1356									
CL407		1220									
CL406		1084									
CL405		948									
CL404		812									
CL403		676									

MODEL	DIM A	DIM B	DIM C	DIMENSION D				DIMENSION E			
				0.75kW	1.1kW	1.5kW	2.2kW	0.75kW	1.1kW	1.5kW	2.2kW
CL210	258	1628	565	238	248	248	258	730	739	765	775
CL209		1492									
CL208		1356									
CL207		1220									
CL206		1084									
CL205		948									
CL204		812									
CL203		676									

L SERIES DISCREEN - 750mm to 1750mm Throats - GA Dimensions
- L000 9900

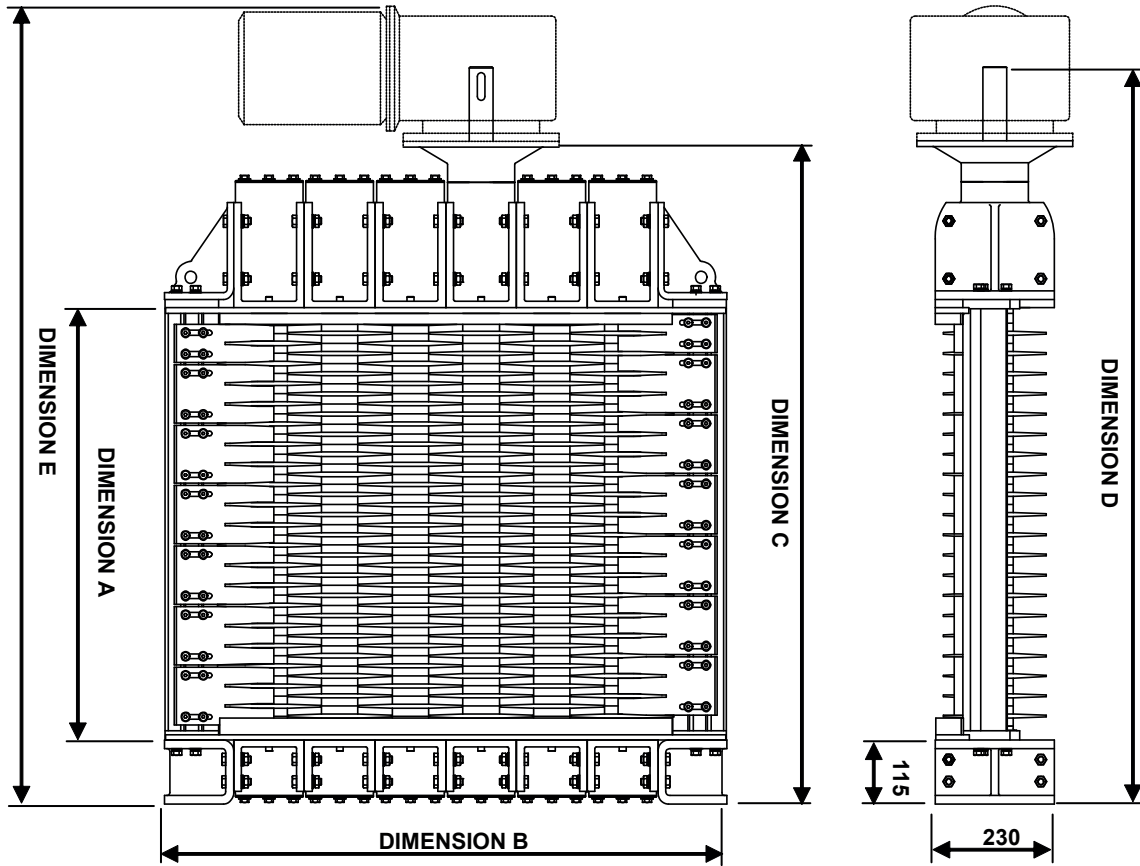

METRIC

Nominal Throat (mm)	Dimension A(mm)	Dimension B (mm)								Dimension C(mm)	Dimension D(mm)	Dimension E(mm)
		No. of Shafts										
		3	4	5	6	7	8	9	10			
750	770	674	810	946	1082	1218	1354	1490	1626	1185	1320	1460
1000	1020									1435	1570	1710
1250	1270									1685	1820	1960
1500	1520									1935	2070	2210
1750	1770									2185	2320	2460



nov.com/industrial

© National Oilwell Varco - All rights reserved