



English

Original
Instructions

Installation, Operation and Maintenance Instructions

Large Compact Range

Index

REVISIONS	3
SPARES AND SERVICE CONTACTS	4
ATEX	5
EC DECLARATION	6
INSTALLATION, OPERATION AND MAINTENANCE	7
LIFTING POINTS	15
WEIGHTS	16
DIAGNOSTICS CHART	17
DRAWING REFERENCE NUMBERS	18
PUMP CODING SHEET	26
FULL PUMP AND QUARTER SECTION	27
DISMANTLING DIAGRAMS	30
ASSEMBLY DIAGRAMS	37
DISMANTLING DIAGRAMS - C1CB AND C1CK	45
ASSEMBLY DIAGRAMS - C1CB AND C1CK	56
EXPLODED VIEWS	71
TORQUE TIGHTENING FIGURES	79
LUBRICATION	80

Spares and Service Contacts

UK

Spares	+44 (0)161 214 2380 (direct line 8.15 am – 5.00 pm)
E-mail	ManchesterSpares@nov.com
Service	+44 (0)161 214 2390 (direct line 8.15 am – 5.00 pm)
E-mail	Customer.Services@nov.com
Service	+44 (0)161 339 9000 (24 hrs)

France

Spares & Service	+33 (0)3 29 94 26 88
E-mail	monofrance@nov.com

Australia

Melbourne	(03) 9773 7777
Sydney	(02) 8536 0900
Brisbane	(07) 3350 4582
Adelaide	(08) 8132 6800
Perth	(08) 9320 5800
Darwin	(08) 8931 3300
E-mail	ozsales@nov.com

New Zealand

Spares & Service	+64 (0)9 829 0333
E-mail	info@mono-pumps.co.nz

USA

Houston Spares & Service	+1 281 854 0300
Ohio Spares & Service	+1 877 486 6966
E-mail	moyno@nov.com

China

Beijing	+86 (0) 10 5707 0900
Shanghai	+86 (0) 21 3990 4558
E-mail	monoshanghai@nov.com

Distributors

For local distribution, please refer to our website:

www.mono-pumps.com/en-uk/sales_network



PUMPS AND PUMP UNITS

Where a pump or pump unit is to be installed in a potentially explosive atmosphere ensure that this has been specified at the time of purchase and that the equipment has been supplied accordingly and displays an ATEX nameplate or is supplied with a certificate of conformity. If there is any doubt as to the suitability of the equipment please contact your supplier before commencing with installation and commissioning.

Process liquids or fluids should be kept within specified temperature limits otherwise the surface of pump or system components may become an ignition source due to temperature rises. Where the process liquid temperature is less than 90°C (194°F) the maximum surface temperature will not exceed 90°C (194°F) provided the pump is installed, operated and maintained in accordance with this manual. Where the process fluid temperature exceeds 90°C (194°F) the maximum surface temperature will be equal to the maximum process fluid temperature.

Cavities that could allow the accumulation of explosive gases, such as under guards, should where possible, be designed out of the system. Where this is not possible they should be fully purged before any work is carried out on the pump or system.

Electrical installation and maintenance work should only be carried out by suitably qualified and competent persons and must be in accordance with relevant electrical regulations.

All electrical equipment, including control and safety devices, should be suitably rated for the environment in to which they are installed.

Where there may be a risk of an accumulation of explosive gases or dust non-sparking tools should be used for installation and maintenance.

In addition to causing permanent damage to the stator, dry running of the pump could generate a rapid rise in the temperature of the stator tube or barrel, which could become an ignition source. It is therefore essential that a dry run protection device be fitted. This must shut the pump down immediately should a dry run situation occur. Details of suitable devices are available from your supplier.

To minimise the risk of sparking or temperature rises due to mechanical or electrical overload the following control and safety devices should be fitted in addition to a dry run protection system. A pressure relief system whereby the pump can not generate pressures in excess of the maximum rated pressure or an over pressure device which should shut the pump down when the maximum discharge pressure is exceeded. A control system that will shut the pump down if the motor current or temperature exceed specified limits. An isolator switch that will disconnect all

electrical supply to the motor and ancillary electrical equipment and be capable of being locked in the off position. All control and safety devices should be fitted, operated and maintained in accordance with the manufacturer's instructions. All valves on the system should be open when the pump is started otherwise serious mechanical overload and failure may result.

It is important that the pump rotates in the direction indicated on the nameplate. This must be checked on installation and commissioning and after any maintenance has been carried out. Failure to observe this may lead to dry running or mechanical or electrical overload.

When fitting drives, couplings, belts, pulleys and guards to a pump or pump unit it is essential that these are correctly fitted, aligned and adjusted in accordance with the manufacturer's instructions. Failure to do so may result in sparking due to unintended mechanical contact or temperature rises due to mechanical or electrical overload or slipping of drive belts. Regular inspection of these parts must be carried out to ensure they are in good condition and replacement of any suspect part must be carried out immediately.

Mechanical seals should be suitably rated for the environment. The seal and any associated equipment, such as a flushing system, must be installed, operated and maintained in accordance with the manufacturer's instructions.

Where a packed gland seal is fitted this must be correctly fitted and adjusted. This type of seal relies on the process liquid to cool the shaft and packing rings so a constant drip of liquid from the gland section is required. Where this is undesirable an alternative seal type should be fitted.

Failure to operate or maintain the pump and ancillary equipment in line with the manufacturer's instructions may lead to premature and potentially dangerous failure of components. Regular inspection, and where necessary replacement, of bearings and lubrication is essential.

The pump and its components have been designed to ensure safe operation within the guidelines covered by legislation. Accordingly your supplier have declared the machine safe to use for the duty specified as defined by the Declaration of Incorporation or Conformity that is issued with this instruction manual.

The use of replacement parts that are not manufactured by or approved by your supplier may affect the safe operation of the pump and it may therefore become a safety hazard to both operators and other equipment. In these circumstances the Declaration provided will become invalid. The guarantee referenced on the Terms and Conditions of Sale will also be invalidated.

EC Declaration as defined by Machinery Directive 2006/42/EC.

The following harmonised standards are applicable: BS EN 809, BS EN ISO 12100:2010

EC Declaration of Incorporation

This declaration is only valid when partly completed machinery has been supplied.

In this case, the machinery meets the requirements of the said directive and is intended for incorporation into other machinery or for assembly with other machinery in order to constitute relevant machinery as defined by the said directive including any amendments, which are valid at the time of supply.

IMPORTANT

This machinery must not be put into service until the relevant machinery into which it is to be incorporated has been declared in conformity to the said directive.

This declaration is only valid when the machinery has been installed, operated and maintained in accordance with these instructions and safety guidelines contained within as well as instructions supplied for equipment assembled with or intended for use with this equipment.

EC Declaration of Conformity

This declaration is not valid for partly completed machinery that has been supplied.

In this case the machinery meets the requirements of the said directive including any amendments which are valid at the time of supply.

We further declare that, where applicable, said machinery also meets the requirements of:

The EMC Directive 2014/30/EU
The Low Voltage Directive 2014/35/EU
The Pressure Equipment Directive 2014/68/EU

IMPORTANT

This declaration is only valid when the machinery has been installed, operated and maintained in accordance with these instructions and safety guidelines contained within as well as instructions supplied for equipment assembled with or intended for use with this equipment.



**Mr A. Morris - Director of Pump Technology for
NOV PFT UK Ltd., Greengate Way, Middleton,
Manchester, England, M24 1SA.**

Installation, Operation & Maintenance

GENERAL DESCRIPTION OF PUMP

The progressive cavity pump is a type of positive displacement pump. The pumping element consists essentially of a fixed rubber stator in the form of a double internal helix and a single helical metal rotor which revolves in the stator and turns on an eccentric path.

The rotor maintains a constant seal inside the stator and this seal travels continuously from one end of the stator to the other, giving a uniform moving cavity.

GENERAL SAFETY

Appropriate PPE must always be worn.

All personnel must be suitable qualified / trained prior to carrying out any work and must comply with all safety warnings.

The Operating and Maintenance manual must always be kept close to the machine.

Instructions must be read prior to carrying out any work.

The machine must be installed correctly to ensure satisfactory & safe operation.

The machine must be maintained to a suitable standard to ensure safety of personnel and satisfactory operation of the machine is achieved.

Ensure adequate ventilation is provided to disperse dangerous concentrations of vapours.

Machines operating on high temperature duties should be allowed to cool sufficiently before any maintenance is carried out.

The machine must be installed with provision for adequate lighting to ensure effective maintenance can be carried out.

DANGERS CAUSED BY THE MACHINE

Movement of mechanical parts

- Risk of entanglement if guards are not used correctly

Electrical voltages and currents

- Risk of electrocution, shock or burns

Hot surfaces

- Risk of burns

INTENDED USE

Use pump only if it is in good condition and in compliance with these instructions.

This machine must be installed in accordance with

statutory regulations and these instructions.

Machine must only be run in accordance with data supplied. Before making any changes, approval must be sought from your Supplier.

FORESEEABLE MISUSE

- Incorrect use of machine
- Incorrect installation of machine
- Removal of guard during operation

ENVIRONMENTAL

These must be taken into account at the place of installation such as:

- abnormal temperature
- high humidity
- corrosive atmospheres
- explosive and/or fire danger zones
- vibrations
- flooding

Type of liquid to be pumped / properties while being pumped:

- flammable
- toxic
- corrosive
- abrasive

Operating System Fluctuations:

- temperature
- pressure
- flow rate
- dry running

TRANSPORT

Comply with any instructions on packaging and/or paperwork.

INSTALLATION

1.1 INSTALLATION AND SAFETY RECOMMENDATIONS

In common with other items of process plant a pump must be installed correctly to ensure satisfactory and safe operation. The pump must also be maintained to a suitable standard. Following these recommendations will ensure that the safety of personnel and satisfactory operation of the pump is achieved.

1.2.1. GENERAL

When handling harmful or objectionable materials, adequate ventilation must be provided in order to

disperse dangerous concentrations of vapours. It is recommended that wherever possible, your Supplier's pumps should be installed with provision for adequate lighting, thus ensuring that effective maintenance can be carried out in satisfactory conditions. With certain product materials, a hosing down facility with adequate drainage will simplify maintenance and prolong the life of pump components.

Pumps operating on high temperature duties should be allowed to cool sufficiently before any maintenance is carried out.

1.2.2. SYSTEM DESIGN & INSTALLATION

At the system design stage, consideration must be given to provision of filler plugs, and the installation of non-return and/or isolating valves. Pumps cannot be reliably used as non-return valves. Pumps in parallel and those with high static discharge head must be fitted with non-return valves.

The pumps must also be protected by suitable devices against over pressure and dry running.

i. HORIZONTAL MOUNTING

All ranges excluding P Range your Supplier's pumps are normally installed in a horizontal position with baseplates mounted on a flat surface, grouted in and bolted, thus ensuring firm fixing and a reduction in noise and vibration.

The unit should be checked after bolting down to ensure that the alignment of the pump to its prime mover is correct.

Ensure pipework is connected in a safe manner (refer to nozzle loads) and protected against harmful external effects.

ii. VERTICAL MOUNTING

P Range Pumps Only

The P range pumps are intended for vertical installation. Care must be taken when lifting the pump into the vertical position.

Normally 'P' range pumps will be designed with a sole plate that will be bolted to the customers framework.

If the pump is to be mounted in any way other than described above, confirmation of the installation must be agreed with your Supplier. All the pipework should be independently supported.

1.3.1 HANDLING



During installation and maintenance, attention must be paid to the safe handling of all items. Where a pump or its components weigh in excess of 20 kg (45lb) it is recommended that suitable lifting tackle should be used to ensure that personal injury or damage to components does not occur.

For safe handling of both bareshaft pumps and pump units (pump/ gearbox/motor etc.) slings should be used. The position of the slings will depend upon the specific pump/unit construction and should be carried out by personnel with the relevant experience to ensure that the pump is not damaged and injury to personnel does not occur.

If eyebolts do exist then these should only be used for lifting the individual components for which they are supplied.

1.3.2 STORAGE AND INFREQUENT OPERATION

The situation where a pump is used infrequently is also covered by the instructions in this section.

SHORT TERM STORAGE

Where a pump has to be stored for 6 months or less then the following steps are advised:

1. Store pump inside wherever possible or if this is not feasible then provide protective covering. Do not allow moisture to collect around the pump.
2. Remove the drain plug, if fitted. Any inspection plates fitted should also be removed to ensure that the suction housing can drain and dry completely.
3. Loosen the packed gland and inject sufficient grease into the stuffing box. Tighten the gland nut hand tight. If a water flush system is to be used do not grease, a small amount of light oil is recommended for these.
4. See Manufacturers Instructions for motor/gearbox/drive instructions for storage procedures.

LONG TERM STORAGE

If the pump is to be kept in storage for more than six months then in addition to the above the following procedures should be carried out regularly (every 2 - 3 weeks if possible):

1. If practicable rotate the pump at least three quarters of one revolution to avoid the rotor setting in the stator.

2. Note, however, that the pump is not to be rotated for more than two revolutions each time because damage could be caused to the rotor/ stator elements.

IMMEDIATELY PRIOR TO INSTALLATION AND STARTING



Before installing the pump please ensure that all plugs and inspection plates are replaced and that excess grease/oil is removed from the stuffing box.

See section 4.2 prior to starting, for instructions on how to fit constant level oilers (where applicable).

1.4 ELECTRICAL



Electrical connection should only be made using equipment suitable for both rating and environment. Where any doubts exist regarding the suitability of equipment, your Supplier, should be consulted before proceeding. Normally the Supplier's pump should be installed with starting equipment arranged to give direct on line starting.

Earthing points will be provided on electric drives (if supplied) and it is essential that these are correctly connected. When the motor is being wired and checked for rotation, the start/stop sequence must be instantaneous to prevent dry running (see 2) or pressurising upstream equipment. (Check direction arrow on pump nameplate). The electrical installation should include appropriate isolating equipment to ensure that the pump unit is safe to work on.

1.5 PRESSURE RELIEF VALVES AND NON-RETURN VALVES

1. It is recommended that a suitable safety device is installed on the discharge side of the pump to prevent over-pressurisation of the system.
2. It is also recommended that a non-return valve is installed on the discharge side of the pump to prevent reverse flow through the system.

When both are installed it is advised that the relief valve is positioned closer to the pump than the nonreturn valve.

IMPORTANT



The pump must never run against a closed inlet or outlet valve, as this could result in mechanical failure.

1.6 GENERAL SAFETY



GREAT CARE MUST BE TAKEN TO PROTECT ALL ELECTRICAL EQUIPMENT FROM SPLASHING WHEN HOSING DOWN. WHERE YOUR SUPPLIER HAS SUPPLIED A BARESHAFT PUMP THE ONUS IS ON THE USER TO FIT ADEQUATE GUARDS IN COMPLIANCE WITH THE REQUIREMENTS OF THE RELEVANT REGULATIONS.

All nuts and bolts, securing flanges and base mounting fixtures must be checked for tightness before operation. To eliminate vibration, the pump must be correctly aligned with the drive unit, and all guards must be securely fixed in position. When commissioning the plant, all joints in the system must be checked thoroughly for leakage.

If, when starting, the pump does not appear to operate correctly (see 2), the plant must be shut down immediately and the cause of the malfunction established before operations are recommenced. It is recommended that depending upon plant system operation, either a combined vacuum and pressure gauge, or a vacuum gauge only be fitted to the pump inlet port, and a pressure gauge fitted to the outlet port, these will then continuously monitor the pump operating conditions. May contain substances from the ECHA SVHC Candidates List (REACH - Regulation (EC) No. 1907/2006)

1.7 DUTY CONDITIONS

Pumps should only be installed on duties for which your Supplier has specified the materials of construction, flow rates, pressure, temperature, speed etc. Where dangerous materials are to be pumped, consideration must be given to the safe discharge from relief valves, gland drains etc.

IF THE DUTY SHOULD BE CHANGED, YOUR SUPPLIER SHOULD BE CONTACTED AND THEIR RECOMMENDATIONS SOUGHT IN THE INTEREST OF APPLICATION, SAFETY OF PLANT, EFFICIENCY AND PUMP LIFE.

2. START-UP PROCEDURE

Pumps must be filled with liquid before starting. The initial filling is not for priming purposes, but to provide the necessary lubrication of the stator until the pump primes itself. When the pump is stopped, sufficient liquid will normally be trapped in the rotor/stator assembly to provide lubrication upon restarting.

If, however, the pump has been left standing for an appreciable time, moved to a new location, or has been dismantled and re-assembled, it must be refilled with liquid and given a few turns before starting. The pump is normally somewhat stiff to turn by hand owing to the close rotor/stator fit. However, this stiffness disappears when the pump is running normally against pressure.

Where fitted, the constant level oiler should be filled with Klubersynth GH6-460 for standard applications or Kluberoil 4UHI 460 for food applications.

2.1 DRY RUNNING



NEVER RUN THE PUMP IN A DRY CONDITION EVEN FOR A FEW REVOLUTIONS OR THE STATOR WILL BE DAMAGED IMMEDIATELY. CONTINUAL DRY RUNNING COULD PRODUCE SOME HARMFUL OR DAMAGING EFFECTS.

2.2 PUMP ROTATION DETAILS

PUMP RANGE	BI-DIRECTIONAL	COMMENT
CB / SB	No	*
Compact	Yes	†
CP0011	No	**
CP0025, CO0800, CP1600	No	*
Dosing	Yes	†
E	Yes	†
Epsilon (inc. Vertical)	Yes	†
EZstrip	Yes	†
G	No	*
Grout Mixer	No	**
Merlin Industrial	Yes	†
Merlin Widethroat	No	**
MM, ML	No	*
Monobloc B	Yes	†
MS	No	**
P	No	*
Placer	No	**
S, SL	Yes	†
W	No	**

*Clockwise when viewed from drive end.

**Anti-clockwise when viewed from drive end.

†Anti-clockwise gives inlet at drive end.

DIRECTIONS OF ROTATION

BEFORE THE DIRECTION OF ROTATION IS CHANGED, YOUR SUPPLIER MUST BE CONSULTED SO THAT THE SUITABILITY OF THE PUMP CAN BE CONFIRMED WHEN OPERATING ON THE NEW DUTY.

2.3.1. GLAND PACKING

Where a pump is supplied fitted with gland packing (manufactured from a non-asbestos material), the gland will require adjustment during the initial running in period. Newly packed glands must be allowed to run-in with only finger tight compression on the gland follower nuts. This should continue for about 3 days. The gland follower should be gradually tightened over the next week to achieve a leakage rate as shown in the table below.

Gland followers should be adjusted at regular intervals to maintain the recommended leakage flow rate. Under normal working conditions a slight drip from the gland under pressure assists in cooling and lubricating the packing. A correctly adjusted gland will always have small leakage of fluid.

Typical Leakage Rates from Packed Glands

SHAFT DIAMETER	NO. OF DROPS PER MINUTE
Up to 50mm (2")	2
50 – 75mm (2 - 3")	3
75 – 100mm (3 - 4")	4
100 – 125mm (4 - 5")	5
125 – 160mm (5 - 6.3")	6

A gland drip is, however, undesirable when handling corrosive, degreasing, or abrasive materials. Under these conditions the gland must be tightened the minimum amount whilst the pump is running to ensure satisfactory sealing when under pressure, or to stop entry of air when under suction conditions.

The gland leakage of toxic, corrosive or hazardous liquids can cause problems of compatibility with the pumps materials of construction.

Provision of a gland drain should be considered, especially for the leakage of hazardous products.



CARE IS REQUIRED WHEN ADJUSTING THE GLAND WHILST PUMP IS RUNNING.

2.3.2 MECHANICAL SEALS - ALL PUMPS

When a mechanical seal is fitted to the pump it may be necessary to provide a barrier fluid to some part of the seal. This should be provided in line with the seal manufacturers instructions.

2.4. GUARDS



In the interests of safety, and in accordance with the U.K. Health and Safety at Work Act 1974, all guards must be replaced after necessary adjustments have been made to the pump.

The onus is on the user to fit the guards in accordance with regulations,

2.5 WARNING/CONTROL DEVICE

Prior to operating the pump, if any warning or control devices are fitted these must be set in accordance with their specific instructions.

2.6 PUMP OPERATING TEMPERATURE

The range of temperatures the pump surfaces will develop is dependent upon factors such as product temperature and ambient temperature of the installation. There may be instances where the external pump surface can exceed 50°C (122°F).

In these instances, personnel must be made aware of this and suitable warnings/guarding used.

2.7 NOISE LEVELS

1. The sound pressure level should not exceed 85dB at one metre (3.3 yards) distance from the pump.
2. This is based on a typical installation and does not necessarily include noise from other sources or any contribution from building reverberation or installation pipework
3. It is recommended the actual pump unit noise levels are ascertained once the unit is installed and running at duty conditions

2.8 LUBRICATION

Pumps fitted with bearings should be inspected periodically to see if grease replenishment is necessary, and if so, grease should be added until the chambers at the ends of the bearing spacer are approximately one third full.

Periodic bearing inspection is necessary to maintain optimum bearing performance. The most expedient time to inspect is during periods of regular scheduled

equipment downtime - for routine maintenance or for any other reason.

Under tropical or other arduous conditions, however, a more frequent examination may be necessary. It is therefore advisable to establish a correct maintenance schedule or periodic inspection.

BP LC2 / Mobilgrease XHP 222 or their equivalent must be used for replenishment.

2.9 PUMP UNITS

Where a pump unit is dismantled and re-assembled, consideration must be given to ensure that where appropriate the following steps are covered.

1. Correct alignment of pump/gearbox
2. Use of appropriate couplings & bushes
3. Use of appropriate belts & pulleys correctly tensioned.

2.10 CLEANING PRIOR TO OPERATION

i. Non Food Use

During the commissioning of a new pump or recommissioning of an overhauled pump, it is advisable to clean the pump prior to the initial operation of the pump in the process.

ii. Food Use

When a pump has been supplied for a food application, it is important to ensure that the pump is clean prior to initial operation of the pump.

Therefore, it is important that a clean-in-place treatment is executed on the pump at the following times:

1. When the pump is first commissioned for use.
2. When any spare components are fitted into the wetted area of the pump.

A recommended CIP procedure is as follows:

This procedure should not be used on the CP Pump Range. Please consult our application engineers for a suitable procedure.

Caustic Wash

LQ94 ex Lever Diversey or equivalent 2% concentration

Acid Wash

P3 Horolith 617 ex Henkel

Ecolab or equivalent 1% concentration

Procedure

1. Caustic wash @ 75°C (167°F) for 20 mins

2. Water rinse @ 80°C (176°) for 20 mins
3. Acid wash @ 50°C (122°F) for 20 mins
4. Water rinse @ 80°C (176°) for 20 mins

- CIP flow rates (hence pump speeds) should be maximised to achieve highest level of cleanability.

A C.I.P. liquid velocity of 1.5 (4.9 ft/s) to 2.0 m/s (6.6 ft/s) is required for removal of solids and soiling.

Pumps fitted with CIP by pass ports will permit higher flow rates without the need to increase pump speed.

- The use of neat active caustic and acid chemicals is not recommended. Proprietary cleaning agents should be used in line with manufacturers instructions.
- All seals and gaskets should be replaced with new if disturbed during maintenance.
- Pump internals should be regularly inspected to ensure hygienic integrity is maintained, especially with respect to elastomeric components and seals, and replaced if necessary.

The four stages constitute one cycle and we recommend that this cycle is used to clean the pump before use on food.

Once the pump has been commissioned, the cleaning process will depend upon the application. The user must therefore ensure that their cleaning procedures are suitable for the duty for which the pump has been purchased.

2.11 EXPLOSIVE PRODUCTS/HAZARDOUS ATMOSPHERES

In certain instances the product being pumped may well be of a hazardous nature.

In these installations consideration must be given to provide suitable protection and appropriate warnings to safeguard personnel and plant.

2.12 ACCESS PORTS



Where access ports are fitted then the following steps must be followed prior to removal:

1. Pump must be shut down and the electrical supply isolated.
2. Protective clothing should be worn, especially if the pumped product is obnoxious.
3. Remove access plate with care utilising where possible drip trays to collect product leakage.

Access ports are included to assist in removing blockages

and to allow a visual check on the components within the suction chamber.

It is not to be considered as an additional method in dismantling the pump.

Re-assembly of the plate should be completed using new gaskets prior to the pump being switched on.

2.13 MAINTENANCE OF WEARING COMPONENTS

2.13.1 ROTOR AND STATOR

The wear rate on these components is dependent on many factors, such as product abrasivity, speed, pressure etc.

When pump performance has reduced to an unacceptable level one or possibly both items will need replacing.

2.13.2 DRIVE SHAFT - PACKED GLAND

The wear rate of the gland area is dependent on many factors such as product abrasivity and speed. Regular gland maintenance will maximise the life of the shaft. Replacement of both the gland packing and shaft will be necessary when shaft sealing becomes difficult to achieve.

2.13.2 COUPLING ROD JOINTS

Regular maintenance and lubrication will maximise life of the joints.

Replacement of one or both joint assemblies and possibly the coupling rod may be necessary when wear is apparent.

It is essential to replace all the joint items with genuine parts from your Supplier to ensure maximum life.

2.13.3 FLEXISHAFT DRIVE PUMPS

With this design there are no wearing items to replace in the drive train, however, if during routine inspection the shaft is visibly damaged / distorted or the protective coating is damaged, then this item should be replaced to avoid unexpected breakdowns.

2.14 MECHANICAL SPEED VARIATORS

Refer to the manufacturers instructions.

These machines require regular maintenance, which typically includes weekly adjustment through the full speed range.

3.0 ASSEMBLY AND DISMANTLING



See assembly and dismantling drawings which contain the steps to dismantle and re-assemble the pump. All fastenings must be tightened securely and when

identified the appropriate torque figures should be used.

3.1 USE OF ITEMS NOT APPROVED OR MANUFACTURED BY YOUR SUPPLIER

The pump and its components have been designed to ensure that the pump will operate safely within the guidelines covered by the legislation.

As a consequence your Supplier has declared the machine safe to use for the duty specified as defined by the Declaration of Incorporation or Conformity that is issued with this Instruction Manual.

The use of replacement items that are not approved by or manufactured by your Supplier may affect the safe operation of the pump and it may therefore become a safety hazard to both operators and other equipment. In these instances the Declaration provided will therefore become invalid. The guarantee referenced in the Terms and Conditions of Sale will also be invalidated if replacement items are used that are not approved or manufactured by your Supplier.

The seller warrants, for a period of 18 months from delivery or 12 months from installations, whichever is earlier, that new Equipment / Parts of its own manufacture shall conform to the material and technical specifications set forth in the agreement. Goods manufactured by others are sold "as is" except to the extent the manufacturer honours any applicable warranty made by the manufacturer.

3.2 FLOWMETER

For increased accuracy a flowmeter can be provided by your Supplier to monitor the flow rate during pump operation. The flowmeter must be installed on the suction end of the pump. Failure to do so may result in damaging effects.

The flowmeter must be used in accordance with the manufacturers instructions.

3.2 DISPOSAL OF WORN COMPONENTS

	NOTICE
	Environmental
	Drain unit in accordance with regulations Dispose correctly in accordance with regulations

When replacing wearing parts, please ensure disposal of used parts is carried out in compliance with local environmental legislation. Particular care should be taken when disposing of lubricants.

4.0 PUMP RANGE SPECIFIC

4.1 DRAINAGE

A drainage port may be provided on the suction chamber and/or end cover.

4.2 VERTICAL MOUNTING - EPSILON / P RANGE

These pumps are intended for vertical inst. Care must be taken when lifting the pump into the vertical position.

Normally these pumps will be designed with a sole plate that will be bolted to the customer's framework.

All vertically mounted pumps require a constant level oiler to be fitted to the gland section in order to prevent the mechanical seals dry running. The oilers will be supplied loose with the pump to avoid damage during transit, so upon receipt of the equipment they will need to be installed prior to operation. Instructions for fitting the oilers are as follows:

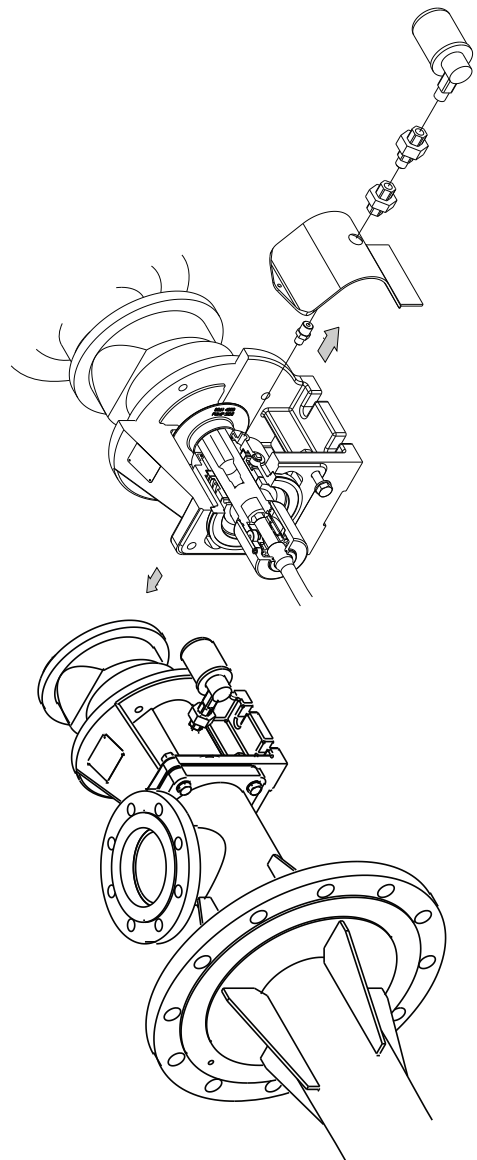

4.3 WIDETHROAT PUMPS

Specific pumps may have auger feed screws, with or without a bridge breaker system to feed the pumping element. If the pump installation requires that these cannot be enclosed, care must be taken to ensure personnel cannot gain access while the pump is operating. If this is not possible, an emergency stop device must be fitted nearby.

Lifting Points

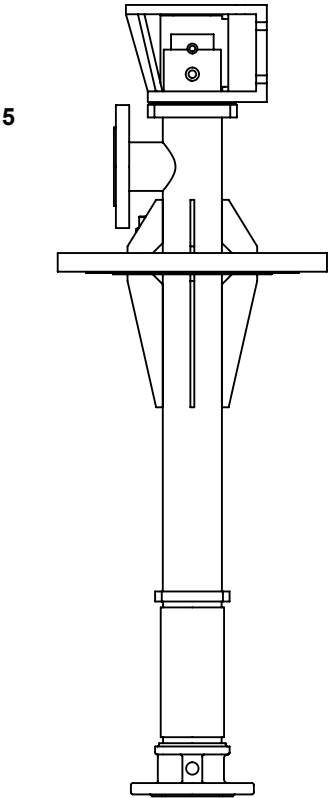
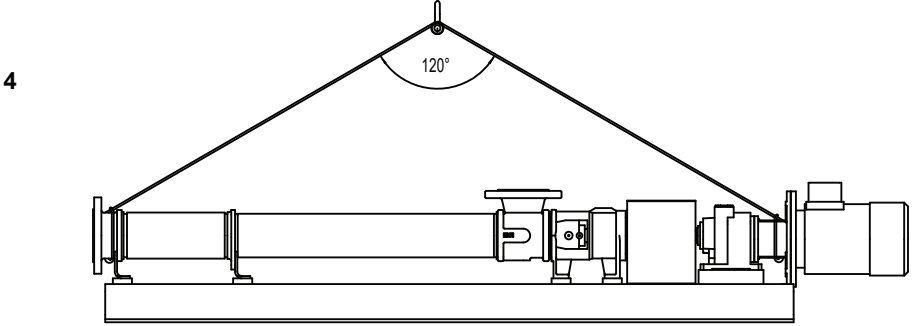
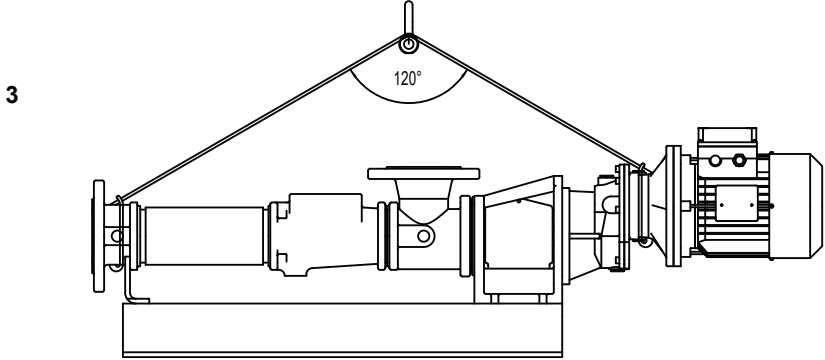
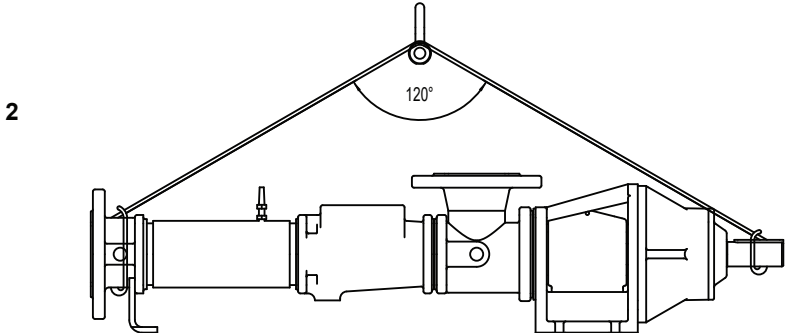
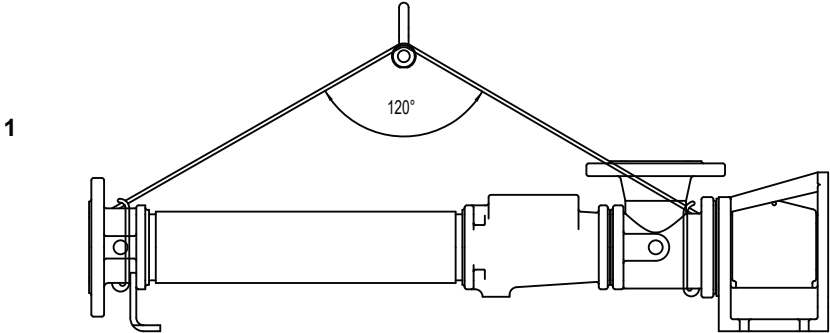

Weights

NOTE:

Weights are for guidance purposes only.

Please refer to the documentation issued with your pump or spares.

Large Compact Range

Model	Weight (kg)				
	Pump	Stator	Rotor	Coupling Rod/Joint	Shaft
C1BB	650	130.0	132.5	21.7	35.4
C1CA	650	85.0	129.1	21.7	35.4
C1CB	950	186.1	263.6	21.9	35.4
C1CK	950	186.1	263.8	21.9	35.4
C1DA	680	121.4	171.3	21.7	35.4
C1DB	862	176.0	186.0	21.7	35.4
C1EB	1213	451.0	262.0	21.7	35.4

Large Compact Range

Model	Weight (lb)				
	Pump	Stator	Rotor	Coupling Rod/Joint	Shaft
C1BB	1433	286.6	292.1	47.8	78.0
C1CA	1433	187.4	284.6	47.8	78.0
C1CB	2094	410.3	581.1	48.3	78.0
C1CK	2094	410.3	581.6	48.3	78.0
C1DA	1499	267.6	377.7	47.8	78.0
C1DB	1900	388.0	410.1	47.8	78.0
C1EB	3674	994.3	577.6	47.8	78.0

Diagnosics Chart

SYMPTOMS	POSSIBLE CAUSES
<ol style="list-style-type: none"> 1. NO DISCHARGE 2. LOSS OF CAPACITY 3. IRREGULAR DISCHARGE 4. PRIMING LOST AFTER START 5. PUMP STALLS AT START UP 6. PUMP OVERHEATS 7. MOTOR OVERHEATS 8. EXCESSIVE POWER ABSORBED BY PUMP 9. NOISE AND VIBRATION 10. PUMP ELEMENT WEAR 11. EXCESSIVE GLAND OR SEAL WEAR 12. GLAND LEAKAGE 13. SEIZURE 	<ol style="list-style-type: none"> 1. 2. 3. 7. 26. 28. 29. 3. 4. 5. 6. 7. 8. 9. 10. 22. 13. 16. 17. 21. 22. 23. 29 3. 4. 5. 6. 7. 8. 13. 15. 29. 3. 4. 5. 6. 7. 8. 13. 15 8. 11. 24. 8. 9. 11. 12. 18. 20 8. 11. 12. 15. 18. 20. 8. 11. 12. 15. 18. 20 3. 4. 5. 6. 7. 8. 9. 11. 13. 15. 18. 19. 20. 22. 23. 27. 31 9. 11. 12. 14. 25. 30. 13. 14. 9. 11. 12. 20.
LIST OF CAUSES	REMEDIAL ACTIONS
<ol style="list-style-type: none"> 1. INCORRECT DIRECTION OF ROTATION 2. PUMP UNPRIMED 3. INSUFFICIENT N.P.S.H. AVAILABLE 4. PRODUCT VAPORISING IN SUPPLY LINE 5. AIR ENTERING SUPPLY LINE 6. INSUFFICIENT HEAD ABOVE SUPPLY VESSEL OUTLET 7. FOOTVALVE/STRAINER OBSTRUCTED OR BLOCKED 8. PRODUCT VISCOSITY ABOVE RATED FIGURE 9. PRODUCT TEMP. ABOVE RATED FIGURE 10. PRODUCT VISCOSITY BELOW RATED FIGURE 11. DELIVERY PRESSURE ABOVE RATED FIGURE 12. GLAND OVERTIGHT 13. GLAND UNDERTIGHT 14. GLAND FLUSHING INADEQUATE 15. PUMP SPEED ABOVE RATED FIGURE 16. PUMP SPEED BELOW RATED FIGURE 17. BELT DRIVE SLIPPING 18. COUPLING MISALIGNED 19. INSECURE PUMP/DRIVE MOUNTING 20. SHAFT BEARING WEAR/FAILURE 21. WORN PUMP ELEMENT 22. RELIEF VALVE CHATTER 23. R.V. INCORRECTLY SET 24. LOW VOLTAGE 25. PRODUCT ENTERING PACKING AREA 26. DRIVE TRAIN BREAKAGE 27. NEGATIVE OR VERY LOW DELIVERY HEAD 28. DISCHARGE BLOCKED/VALVE CLOSED 29. STATOR TURNING 30. STUFFING BOX 'EATS' PACKING 31. VEE BELTS 	<ol style="list-style-type: none"> 1. REVERSE MOTOR 2. BLEED SYSTEM OF AIR/GAS 3. INCREASE SUCTION HEAD OR REDUCE SPEED/TEMP. 4. INCREASE N.P.S.H. AVAILABLE (SEE 3 ABOVE) 5. CHECK PIPE JOINTS/GLAND ADJUSTMENT 6. RAISE VESSEL/INCREASE PIPE SIZE 7. CLEAN OUT SUCTION LINE/VALVES 8. DECREASE PUMP SPEED/INCREASE TEMP. 9. COOL THE PRODUCT 10. INCREASE PUMP SPEED/REDUCE TEMP. 11. CHECK FOR BLOCKAGES IN DELIVERY LINE 12. ADJUST GLAND SEE O&M INSTRUCTIONS 13. ADJUST GLAND SEE O&M INSTRUCTIONS 14. CHECK FLUID FLOWS FREELY INTO GLAND 15. DECREASE PUMP SPEED 16. INCREASE PUMP SPEED 17. RE-TENSION BELTS 18. CHECK AND ADJUST ALIGNMENT 19. CHECK AND TIGHTEN ALL PUMP MOUNTINGS 20. REPLACE BEARINGS 21. FIT NEW PARTS 22. CHECK CONDITION OF VALVE/RENEW 23. RE-ADJUST SPRING COMPRESSION 24. CHECK VOLTAGE/WIRING SIZES 25. CHECK PACKING CONDITION AND TYPE 26. CHECK AND REPLACE BROKEN COMPONENTS 27. CLOSE DELIVERY VALVE SLIGHTLY 28. REVERSE PUMP/RELIEVE PRESSURE/CLEAR BLOCKAGES 29. REPLACE WORN PARTS/TIGHTEN UP STATOR BOLTS 30. CHECK FOR WORN SHAFT AND REPLACE 31. CHECK AND ADJUST TENSION OR REPLACE

Drawing Reference Numbers

C1BB MONOBLOC

DRG REF	DESCRIPTION
01A	BODY
01B	BODY ADAPTOR
06A	NAMEPLATE (SOG)
06B	NAMEPLATE (DOG)
08A	GLAND FOLLOWER
10A	GLAND PACKING SET (6 RINGS)
15A	THROWER GUARD
20B	GASKET - GLAND
20C	INSPECTION PORT GASKET
20E	GLAND GASKET
22A	STATOR
23A	SUCTION CHAMBER
24A	END COVER
25A	ROTOR
26A	COUPLING ROD
27A	COUPLING ROD BUSH
27B	COUPLING ROD BUSH
27C	ROTOR / SHAFT BUSH
27D	ROTOR / SHAFT BUSH
28A	SEALING BOOT
28B	SEALING BOOT
29A	COUPLING ROD PIN
29B	COUPLING ROD PIN
29C	SHAFT PIN
32A	DRIVE SHAFT
42A	THROWER
59A	INSPECTION PORT COVER
62A	SUPPORT FOOT
65A	GLAND SECTION
75A	ROTOR / SHAFT SLEEVE
75B	ROTOR / SHAFT SLEEVE
95A	TIE BAR

DRG REF	DESCRIPTION
P201	PLAIN WASHER
P202	SPRING WASHER
P203	HEX NUT
P204	STUD
P205	TAPER PLUG
P401	O RING
P402	HEX SOCKET SET
P403	TIE STRAP
P404	TIE STRAP
P405	HEX SOCKET SET
P406	O RING
P501	TAPER PLUG
P502	PLAIN WASHER
P503	SPRING WASHER
P504	HEX NUT
P505	TAPER PLUG
P506	PLAIN WASHER
P507	SPRING WASHER
P508	HEX NUT
P509	STUD
P510	PLAIN WASHER
P511	SPRING WASHER
P512	HEX NUT
P523	STUD
P524	SPRING WASHER
P525	PLAIN WASHER
P526	HEX NUT
P527	STUD
P528	SPRING WASHER
P529	PLAIN WASHER
P530	HEX NUT
P600	HEX HEAD SCREW
P601	PLAIN WASHER
P602	SPRING WASHER
P603	HEX NUT

IMPORTANT NOTE

THE DRAWING REFERENCES SHOWN GIVE THE DESCRIPTION OF ALL THE PARTS DETAILED ON THE SECTIONAL DRAWINGS IN THIS SECTION OF THE BOOK. THEREFORE SOME OF THE REFERENCES MAY NOT BE SHOWN ON ANY ONE.

C1BB BARESHAFT

DRG REF	DESCRIPTION
01A	BODY
01B	BODY ADAPTOR
06A	NAMEPLATE (SOG)
08A	GLAND FOLLOWER
10A	GLAND PACKING SET (6 RINGS)
11A	BEARING COVER
15A	THROWER GUARD
20B	GASKET - GLAND
20C	INSPECTION PORT GASKET
20E	GLAND GASKET
22A	STATOR
23A	SUCTION CHAMBER
24A	END COVER
25A	ROTOR
26A	COUPLING ROD
27A	COUPLING ROD BUSH
27B	COUPLING ROD BUSH
27C	ROTOR / SHAFT BUSH
27D	ROTOR / SHAFT BUSH
28A	SEALING BOOT
28B	SEALING BOOT
29A	COUPLING ROD PIN
29B	COUPLING ROD PIN
29C	SHAFT PIN
32A	DRIVE SHAFT
35A	BEARING SPACER
42A	THROWER
59A	INSPECTION PORT COVER
62A	SUPPORT FOOT
65A	GLAND SECTION
75A	ROTOR / SHAFT SLEEVE
75B	ROTOR / SHAFT SLEEVE
95A	TIE BAR

DRG REF	DESCRIPTION
P101	TAPER ROLLER BEARING
P102	TAPER ROLLER BEARING
P103	ROTARY SHAFT LIPSEAL
P104	ROTARY SHAFT LIPSEAL
P105	HEX HEAD BOLT
P106	HEX NUT
P107	PLAIN WASHER
P108	SPRING WASHER
P110	PLAIN WASHER
P111	HEX HEAD SCREW
P112	SPRING WASHER
P201	PLAIN WASHER
P202	SPRING WASHER
P203	HEX NUT
P204	STUD
P205	TAPER PLUG
P301	KEY
P401	O RING
P402	HEX SOCKET SET
P403	TIE STRAP
P404	TIE STRAP
P405	HEX SOCKET SET
P406	O RING
P501	TAPER PLUG
P502	PLAIN WASHER
P503	SPRING WASHER
P504	HEX NUT
P505	TAPER PLUG
P506	PLAIN WASHER
P507	SPRING WASHER
P508	HEX NUT
P509	STUD
P510	PLAIN WASHER
P511	SPRING WASHER
P512	HEX NUT
P523	STUD
P524	SPRING WASHER
P525	PLAIN WASHER
P526	HEX NUT
P527	STUD
P528	SPRING WASHER
P529	PLAIN WASHER
P530	HEX NUT

IMPORTANT NOTE

THE DRAWING REFERENCES SHOWN GIVE THE DESCRIPTION OF ALL THE PARTS DETAILED ON THE SECTIONAL DRAWINGS IN THIS SECTION OF THE BOOK. THEREFORE SOME OF THE REFERENCES MAY NOT BE SHOWN ON ANY ONE.

C1CA & C1DA MONOBLOC

DRG REF	DESCRIPTION
01A	BODY
06A	NAMEPLATE (SOG)
06B	NAMEPLATE (DOG)
08A	GLAND FOLLOWER
10A	GLAND PACKING SET (6 RINGS)
15A	THROWER GUARD
20B	GASKET - GLAND
20C	INSPECTION PORT GASKET
22A	STATOR
23A	SUCTION CHAMBER
24A	END COVER
25A	ROTOR
26A	COUPLING ROD
27A	COUPLING ROD BUSH
27B	COUPLING ROD BUSH
27C	ROTOR / SHAFT BUSH
27D	ROTOR / SHAFT BUSH
28A	SEALING BOOT
28B	SEALING BOOT
29A	COUPLING ROD PIN
29B	COUPLING ROD PIN
29C	SHAFT PIN
32A	DRIVE SHAFT
42A	THROWER
59A	INSPECTION PORT COVER
62A	SUPPORT FOOT
65A	GLAND SECTION
75A	ROTOR / SHAFT SLEEVE
75B	ROTOR / SHAFT SLEEVE
95A	TIE BAR

DRG REF	DESCRIPTION
P101	HEX HEAD SCREW
P102	PLAIN WASHER
P103	SPRING WASHER
P104	HEX NUT
P201	PLAIN WASHER
P202	SPRING WASHER
P203	HEX NUT
P204	STUD
P205	TAPER PLUG
P401	O RING
P402	HEX SOCKET SET
P403	TIE STRAP
P404	TIE STRAP
P405	HEX SOCKET SET
P406	O RING
P501	TAPER PLUG
P502	PLAIN WASHER
P503	SPRING WASHER
P504	HEX NUT
P505	TAPER PLUG
P506	PLAIN WASHER
P507	SPRING WASHER
P508	HEX NUT
P509	STUD
P510	PLAIN WASHER
P511	SPRING WASHER
P512	HEX NUT
P600	HEX HEAD SCREW
P601	PLAIN WASHER
P602	SPRING WASHER
P603	HEX NUT

IMPORTANT NOTE

THE DRAWING REFERENCES SHOWN GIVE THE DESCRIPTION OF ALL THE PARTS DETAILED ON THE SECTIONAL DRAWINGS IN THIS SECTION OF THE BOOK. THEREFORE SOME OF THE REFERENCES MAY NOT BE SHOWN ON ANY ONE.

C1CA & C1DA BARESHAFT

DRG REF	DESCRIPTION
01A	BODY
06A	NAMEPLATE (SOG)
08A	GLAND FOLLOWER
10A	GLAND PACKING SET (6 RINGS)
11A	BEARING COVER
15A	THROWER GUARD
20B	GASKET - GLAND
20C	INSPECTION PORT GASKET
22A	STATOR
23A	SUCTION CHAMBER
24A	END COVER
25A	ROTOR
26A	COUPLING ROD
27A	COUPLING ROD BUSH
27B	COUPLING ROD BUSH
27C	ROTOR / SHAFT BUSH
27D	ROTOR / SHAFT BUSH
28A	SEALING BOOT
28B	SEALING BOOT
29A	COUPLING ROD PIN
29B	COUPLING ROD PIN
29C	SHAFT PIN
32A	DRIVE SHAFT
35A	SHAFT
35A	BEARING SPACER
42A	THROWER
59A	INSPECTION PORT COVER
62A	SUPPORT FOOT
65A	GLAND SECTION
75A	ROTOR / SHAFT SLEEVE
75B	ROTOR / SHAFT SLEEVE
95A	TIE BAR

DRG REF	DESCRIPTION
P101	TAPER ROLLER BEARING
P102	TAPER ROLLER BEARING
P103	ROTARY SHAFT LIPSEAL
P104	ROTARY SHAFT LIPSEAL
P105	HEX HEAD BOLT
P106	HEX NUT
P107	PLAIN WASHER
P108	SPRING WASHER
P110	PLAIN WASHER
P111	HEX HEAD SCREW
P112	SPRING WASHER
P201	PLAIN WASHER
P202	SPRING WASHER
P203	HEX NUT
P204	STUD
P205	TAPER PLUG
P301	KEY
P401	O RING
P402	HEX SOCKET SET
P403	TIE STRAP
P404	TIE STRAP
P405	HEX SOCKET SET
P406	O RING
P501	TAPER PLUG
P502	PLAIN WASHER
P503	SPRING WASHER
P504	HEX NUT
P505	TAPER PLUG
P506	PLAIN WASHER
P507	SPRING WASHER
P508	HEX NUT
P509	STUD
P510	PLAIN WASHER
P511	SPRING WASHER
P512	HEX NUT
P523	STUD

IMPORTANT NOTE

THE DRAWING REFERENCES SHOWN GIVE THE DESCRIPTION OF ALL THE PARTS DETAILED ON THE SECTIONAL DRAWINGS IN THIS SECTION OF THE BOOK. THEREFORE SOME OF THE REFERENCES MAY NOT BE SHOWN ON ANY ONE.

C1CK & C1CB MONOBLOC

DRG REF	DESCRIPTION
01A	BODY
06A	NAMEPLATE (SOG)
06B	NAMEPLATE (DOG)
08A	GLAND FOLLOWER
10A	GLAND PACKING SET (6 RINGS)
15A	THROWER GUARD
20B	GASKET - GLAND
20C	INSPECTION PORT GASKET
22A	STATOR
23A	SUCTION CHAMBER
24A	END COVER
25A	ROTOR
26A	COUPLING ROD
27A	COUPLING ROD BUSH
28A	SEALING BOOT
29A	COUPLING ROD PIN
29B	SHAFT PIN
30A	COUPLING YOKE
30B	COUPLING BLOCK
30C	BEARING WASHER
32A	DRIVE SHAFT
42A	THROWER
59A	INSPECTION PORT COVER
62A	SUPPORT FOOT
65A	GLAND SECTION
75A	ROTOR / SHAFT SLEEVE
95A	TIE BAR

DRG REF	DESCRIPTION
P101	HEX HEAD SCREW
P102	PLAIN WASHER
P103	SPRING WASHER
P104	HEX NUT
P201	PLAIN WASHER
P202	SPRING WASHER
P203	HEX NUT
P204	STUD
P205	TAPER PLUG
P401	O RING
P402	ROLL PIN
P403	ROLL PIN
P404	SOCKET SET SCREW
P405	ROLL PIN
P406	SOCKET BUTTON HEAD SCREW
P407	ROLLER BEARING
P408	THRUST WASHER
P409	O RING
P410	O RING
P411	O RING
P501	TAPER PLUG
P502	PLAIN WASHER
P503	SPRING WASHER
P504	HEX NUT
P505	TAPER PLUG
P506	PLAIN WASHER
P507	SPRING WASHER
P508	HEX NUT
P509	STUD
P510	PLAIN WASHER
P511	SPRING WASHER
P512	HEX NUT
P600	HEX HEAD SCREW
P601	PLAIN WASHER
P602	SPRING WASHER
P603	HEX NUT

IMPORTANT NOTE

THE DRAWING REFERENCES SHOWN GIVE THE DESCRIPTION OF ALL THE PARTS DETAILED ON THE SECTIONAL DRAWINGS IN THIS SECTION OF THE BOOK. THEREFORE SOME OF THE REFERENCES MAY NOT BE SHOWN ON ANY ONE.

C1DB & C1EB MONOBLOC

DRG REF	DESCRIPTION
01A	BODY
06A	NAMEPLATE (SOG)
06B	NAMEPLATE (DOG)
08A	GLAND FOLLOWER
10A	GLAND PACKING SET (6 RINGS)
12A	STATOR ANTI-ROTATION RING
15A	THROWER GUARD
20B	GASKET - GLAND
20C	INSPECTION PORT GASKET
22A	STATOR
23A	SUCTION CHAMBER
24A	END COVER
25A	ROTOR
26A	COUPLING ROD
27A	COUPLING ROD BUSH
28A	SEALING BOOT
29A	COUPLING ROD PIN
29B	SHAFT PIN
30A	COUPLING YOKE
30B	COUPLING BLOCK
30C	BEARING WASHER
32A	DRIVE SHAFT
42A	THROWER
59A	INSPECTION PORT COVER
62A	SUPPORT FOOT
65A	GLAND SECTION
75A	ROTOR / SHAFT SLEEVE
95A	TIE BAR

DRG REF	DESCRIPTION
P101	HEX HEAD SCREW
P102	PLAIN WASHER
P103	SPRING WASHER
P104	HEX NUT
P201	PLAIN WASHER
P202	SPRING WASHER
P203	HEX NUT
P204	STUD
P205	TAPER PLUG
P401	O RING
P402	ROLL PIN
P403	ROLL PIN
P404	SOCKET SET SCREW
P405	ROLL PIN
P406	SOCKET BUTTON HEAD SCREW
P407	ROLLER BEARING
P408	THRUST WASHER
P409	O RING
P410	O RING
P411	O RING
P501	TAPER PLUG
P502	PLAIN WASHER
P503	SPRING WASHER
P504	HEX NUT
P505	TAPER PLUG
P506	PLAIN WASHER
P507	SPRING WASHER
P508	HEX NUT
P509	STUD
P510	PLAIN WASHER
P511	SPRING WASHER
P512	HEX NUT
P513	HEX HEAD SCREW
P514	PLAIN WASHER
P515	HEX NUT
P600	HEX HEAD SCREW
P601	PLAIN WASHER
P602	SPRING WASHER
P603	HEX NUT

IMPORTANT NOTE

THE DRAWING REFERENCES SHOWN GIVE THE DESCRIPTION OF ALL THE PARTS DETAILED ON THE SECTIONAL DRAWINGS IN THIS SECTION OF THE BOOK. THEREFORE SOME OF THE REFERENCES MAY NOT BE SHOWN ON ANY ONE.

C1CK & C1CB BARESHAFT

DRG REF	DESCRIPTION
01A	BODY
06A	NAMEPLATE (SOG)
08A	GLAND FOLLOWER
10A	GLAND PACKING SET (6 RINGS)
11A	BEARING COVER
15A	THROWER GUARD
20B	GASKET - GLAND
20C	INSPECTION PORT GASKET
22A	STATOR
23A	SUCTION CHAMBER
24A	END COVER
25A	ROTOR
26A	COUPLING ROD
27A	COUPLING ROD BUSH
28A	SEALING BOOT
29A	COUPLING ROD PIN
29B	SHAFT PIN
30A	COUPLING YOKE
30B	COUPLING BLOCK
30C	BEARING WASHER
32A	DRIVE SHAFT
32B	SHAFT
35A	BEARING SPACER
42A	THROWER
59A	INSPECTION PORT COVER
62A	SUPPORT FOOT
65A	GLAND SECTION
75A	ROTOR / SHAFT SLEEVE
95A	TIE BAR

DRG REF	DESCRIPTION
P101	TAPER ROLLER BEARING
P102	TAPER ROLLER BEARING
P103	ROTARY SHAFT LIPSEAL
P104	ROTARY SHAFT LIPSEAL
P105	HEX HEAD BOLT
P106	HEX NUT
P107	PLAIN WASHER
P108	SPRING WASHER
P110	PLAIN WASHER
P111	HEX HEAD SCREW
P112	SPRING WASHER
P201	PLAIN WASHER
P202	SPRING WASHER
P203	HEX NUT
P204	STUD
P205	TAPER PLUG
P301	KEY
P401	O RING
P402	ROLL PIN
P403	ROLL PIN
P404	SOCKET SET SCREW
P405	ROLL PIN
P406	SOCKET BUTTON HEAD SCREW
P407	CLINDER ROLLER BEARING
P408	THRUST WASHER
P409	O RING
P410	O RING
P411	O RING
P412	LOCKNUT
P413	LOCKWASHER
P501	TAPER PLUG
P502	PLAIN WASHER
P503	SPRING WASHER
P504	HEX NUT
P505	TAPER PLUG
P506	PLAIN WASHER
P507	SPRING WASHER
P508	HEX NUT
P509	STUD
P510	PLAIN WASHER
P511	SPRING WASHER
P512	HEX NUT

IMPORTANT NOTE

THE DRAWING REFERENCES SHOWN GIVE THE DESCRIPTION OF ALL THE PARTS DETAILED ON THE SECTIONAL DRAWINGS IN THIS SECTION OF THE BOOK. THEREFORE SOME OF THE REFERENCES MAY NOT BE SHOWN ON ANY ONE.

C1DB & C1EB BARESHAFT

DRG REF	DESCRIPTION
01A	BODY
06A	NAMEPLATE (SOG)
08A	GLAND FOLLOWER
10A	GLAND PACKING SET (6 RINGS)
11A	BEARING COVER
12A	STATOR ANTI-ROTATION RING
15A	THROWER GUARD
20B	GASKET - GLAND
20C	INSPECTION PORT GASKET
22A	STATOR
23A	SUCTION CHAMBER
24A	END COVER
25A	ROTOR
26A	COUPLING ROD
27A	COUPLING ROD BUSH
28A	SEALING BOOT
29A	COUPLING ROD PIN
29B	SHAFT PIN
30A	COUPLING YOKE
30B	COUPLING BLOCK
30C	BEARING WASHER
32A	DRIVE SHAFT
32B	SHAFT
35A	BEARING SPACER
42A	THROWER
59A	INSPECTION PORT COVER
62A	SUPPORT FOOT
65A	GLAND SECTION
75A	ROTOR / SHAFT SLEEVE
95A	TIE BAR
P101	TAPER ROLLER BEARING
P102	TAPER ROLLER BEARING
P103	ROTARY SHAFT LIPSEAL
P104	ROTARY SHAFT LIPSEAL
P105	HEX HEAD BOLT
P106	HEX NUT
P107	PLAIN WASHER
P108	SPRING WASHER

DRG REF	DESCRIPTION
P110	PLAIN WASHER
P111	HEX HEAD SCREW
P112	SPRING WASHER
P201	PLAIN WASHER
P202	SPRING WASHER
P203	HEX NUT
P204	STUD
P205	TAPER PLUG
P301	KEY
P401	O RING
P402	ROLL PIN
P403	ROLL PIN
P404	SOCKET SET SCREW
P405	ROLL PIN
P406	SOCKET BUTTON HEAD SCREW
P407	CLINDER ROLLER BEARING
P408	THRUST WASHER
P409	O RING
P410	O RING
P411	O RING
P412	LOCKNUT
P413	LOCKWASHER
P501	TAPER PLUG
P502	PLAIN WASHER
P503	SPRING WASHER
P504	HEX NUT
P505	TAPER PLUG
P506	PLAIN WASHER
P507	SPRING WASHER
P508	HEX NUT
P509	STUD
P510	PLAIN WASHER
P511	SPRING WASHER
P512	HEX NUT
P513	HEX HEAD SCREW
P514	PLAIN WASHER
P515	HEX NUT

IMPORTANT NOTE

THE DRAWING REFERENCES SHOWN GIVE THE DESCRIPTION OF ALL THE PARTS DETAILED ON THE SECTIONAL DRAWINGS IN THIS SECTION OF THE BOOK. THEREFORE SOME OF THE REFERENCES MAY NOT BE SHOWN ON ANY ONE.

Pump Coding

Range	Monobloc Compact	C																			
	Monobloc Compact Square Inlet	S																			
DesignMarkNo.	Monobloc		1																		
	Monobloc (January 2007)		2																		
Size	1.3m ³ /h (5.7 USGPM) @ 1750 rpm			1																	
	3.3m ³ /h (14.5 USGPM) @ 1750 rpm			2																	
	10m ³ /h (44 USGPM) @ 1500 rpm			3																	
	13m ³ /h (66 USGPM) @ 1000 rpm			X																	
	22m ³ /h (97 USGPM) @ 1000 rpm			4																	
	37m ³ /h (163 USGPM) @ 800 rpm			5																	
	57m ³ /h (251 USGPM) @ 700 rpm			6																	
	79m ³ /h (348 USGPM) @ 600 rpm			7																	
	97m ³ /h (427 USGPM) @ 500 rpm			8																	
	125m ³ /h (551 USGPM) @ 450 rpm			9																	
	165m ³ /h (727 USGPM) @ 400 rpm			A																	
	225m ³ /h (991 USGPM) @ 350 rpm			B																	
	440m ³ /h (1938 USGPM) @ 270 rpm			C																	
	310m ³ /h (1366 USGPM) @ 250 rpm (Trilobe)			D																	
450m ³ /h (1982 USGPM) @ 250 rpm (Trilobe)			E																		
Stages	Single stage				A																
	Two stage				B																
	Four stage				D																
	Single stage - extended pitch				K																
Casing Material	Cast iron					C															
	Stainless steel					S															
Rotating Parts	Code 1						1														
	Code 5						5														
	Code 8						8														
Rotor Mark No	MK 0 (Oversized)						0														
	MK 1 (Standard)						1														
	MK 3 (Temperature)						3														
	MK 5 (Temperature)						5														
Stator Mat'l	RA, RR etc.									R											
Seal Type	Mechanical Seal											M									
	Packed Gland											P									
Build Option	Refer to product manual section 2 & 3, drive selections												A								
													B								
													H								
/																		/			
Variation	For special requirements contact your Supplier																	A	1	2	3

Example

C C Range
1 Design MK 1
X Size 0X
A Single Stage
C Cast Iron
8 Code 8 Rot Parts
1 MK1 Rotor
R Nitrile Stator
M Mechanical Seal
A Build Option A

Note: Refer to Pre Selection Table for availability of pump models.

1: 2 stage D & E sizes are available in 2:3 (Trilobe) geometry only.

2: For other material options please contact your Supplier.

Full Pump and Quarter Section

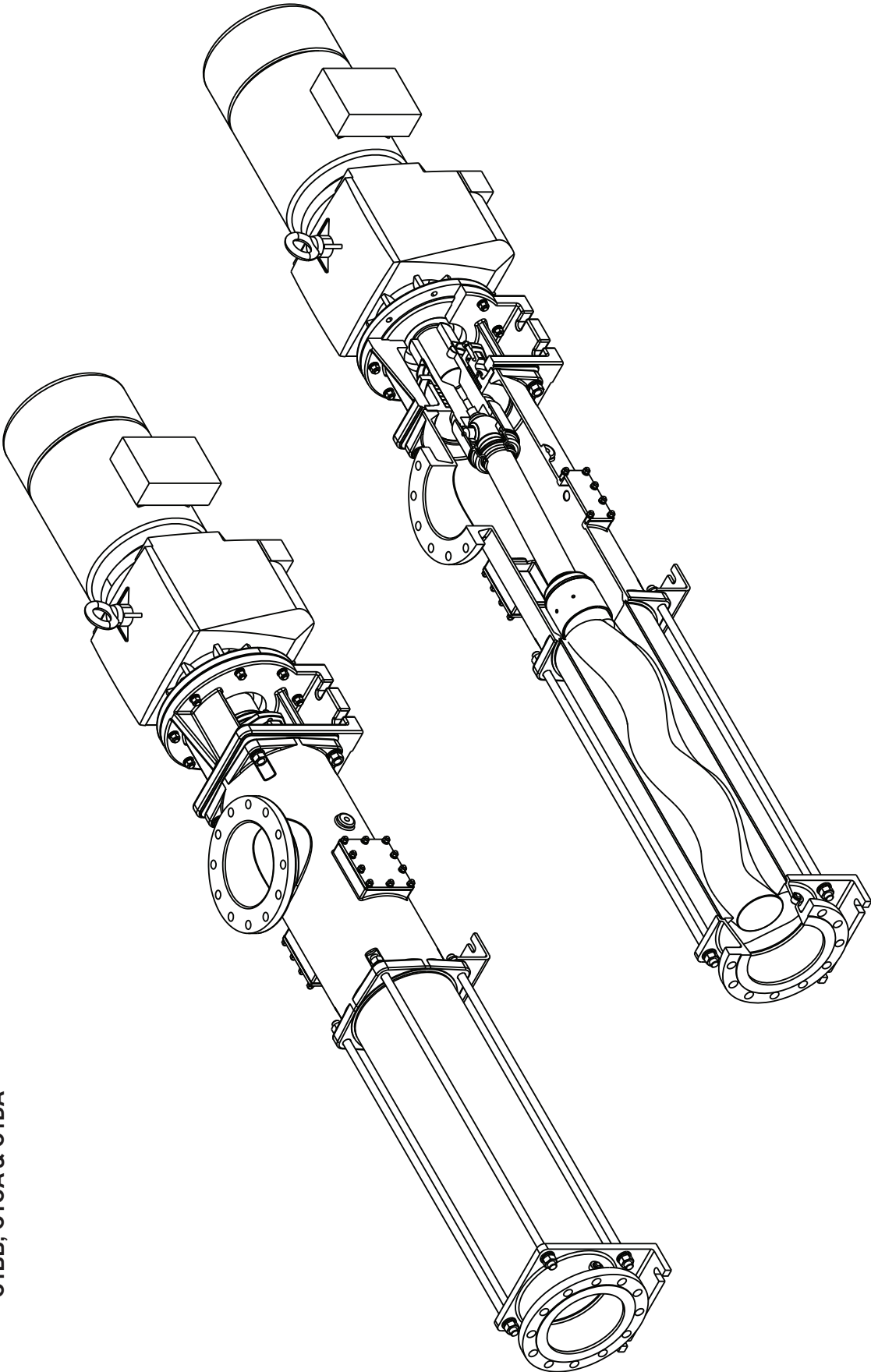

COMPACT RANGE
C1BB, C1CA & C1DA

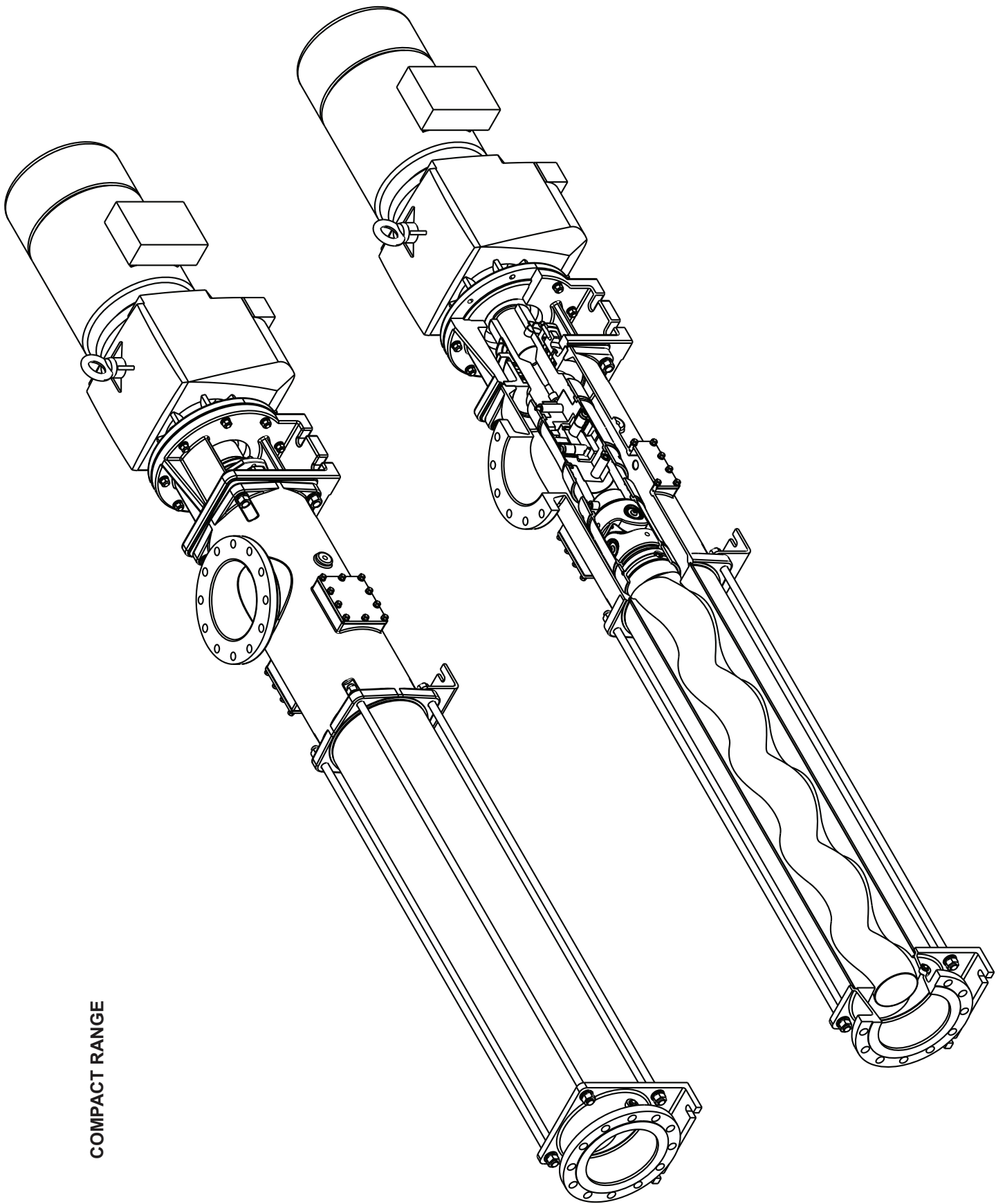

COMPACT RANGE

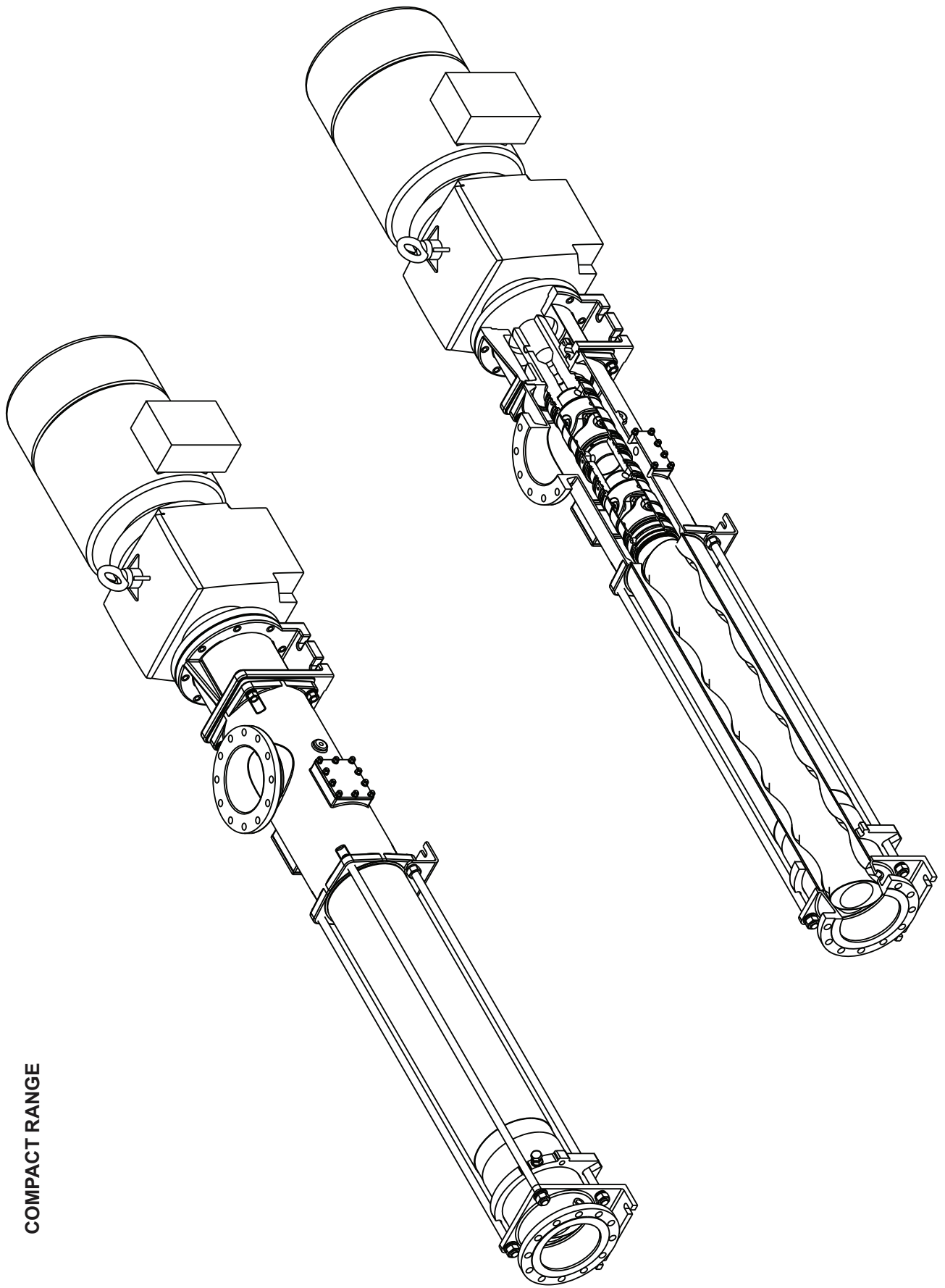

COMPACT RANGE

Dismantling

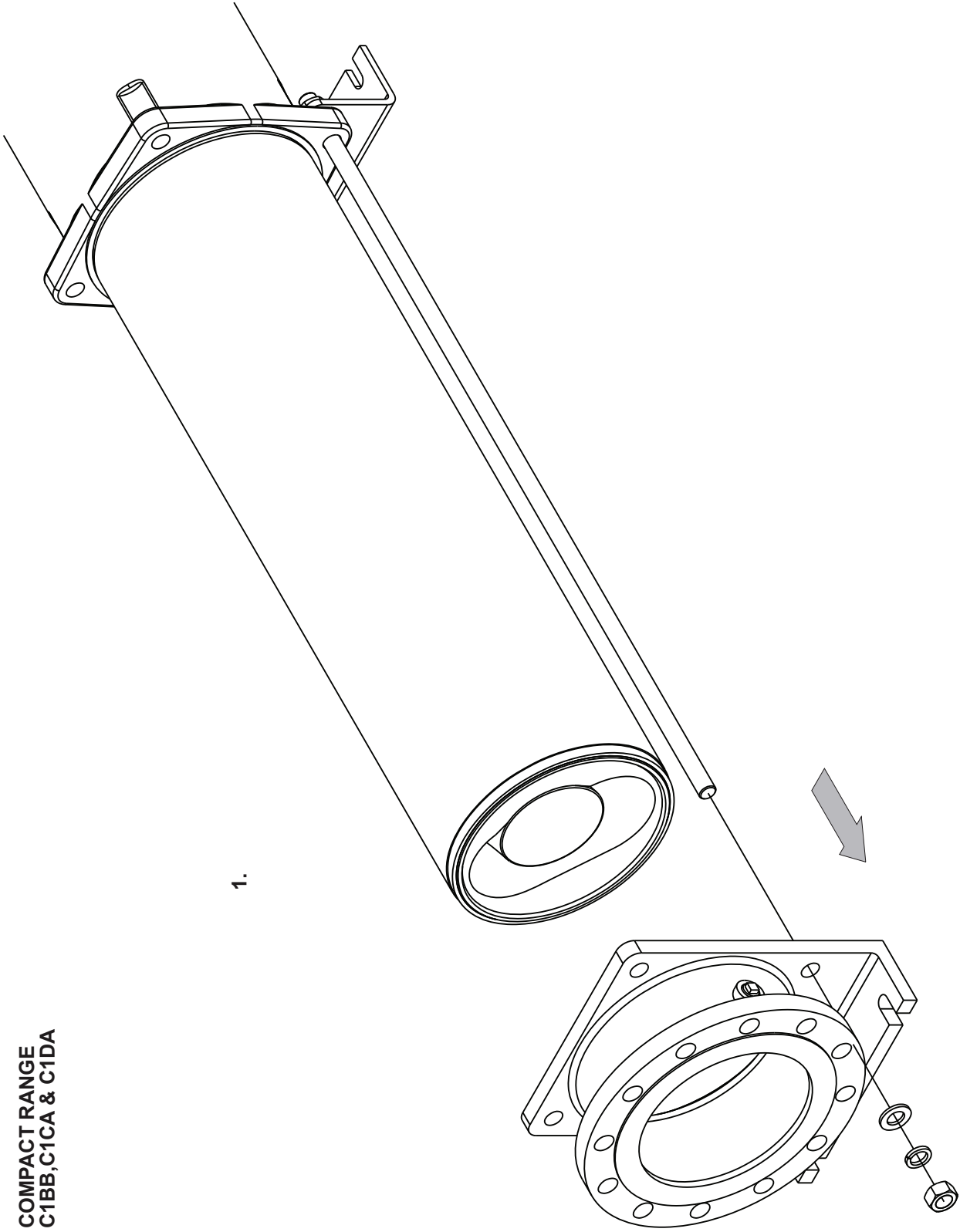

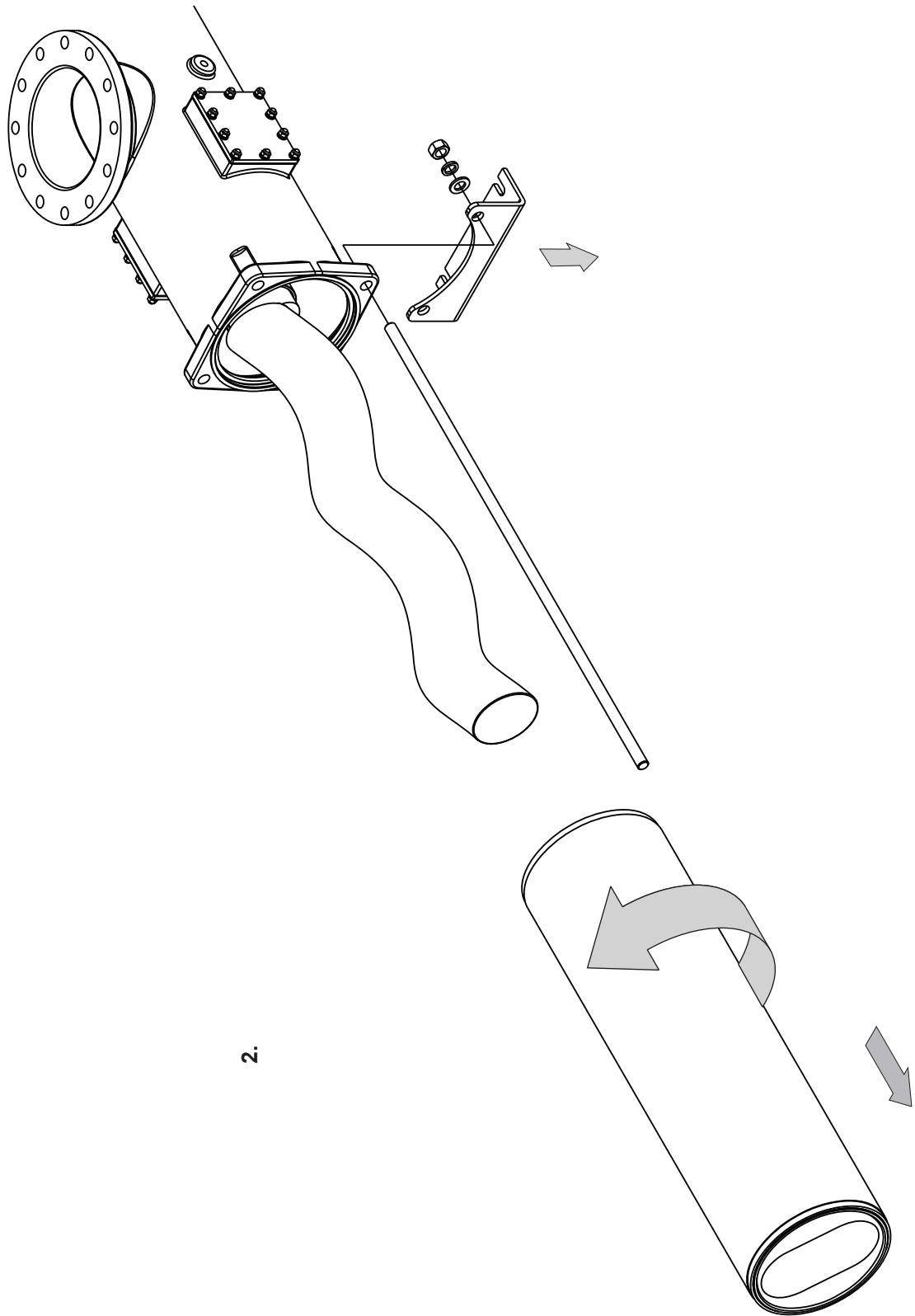

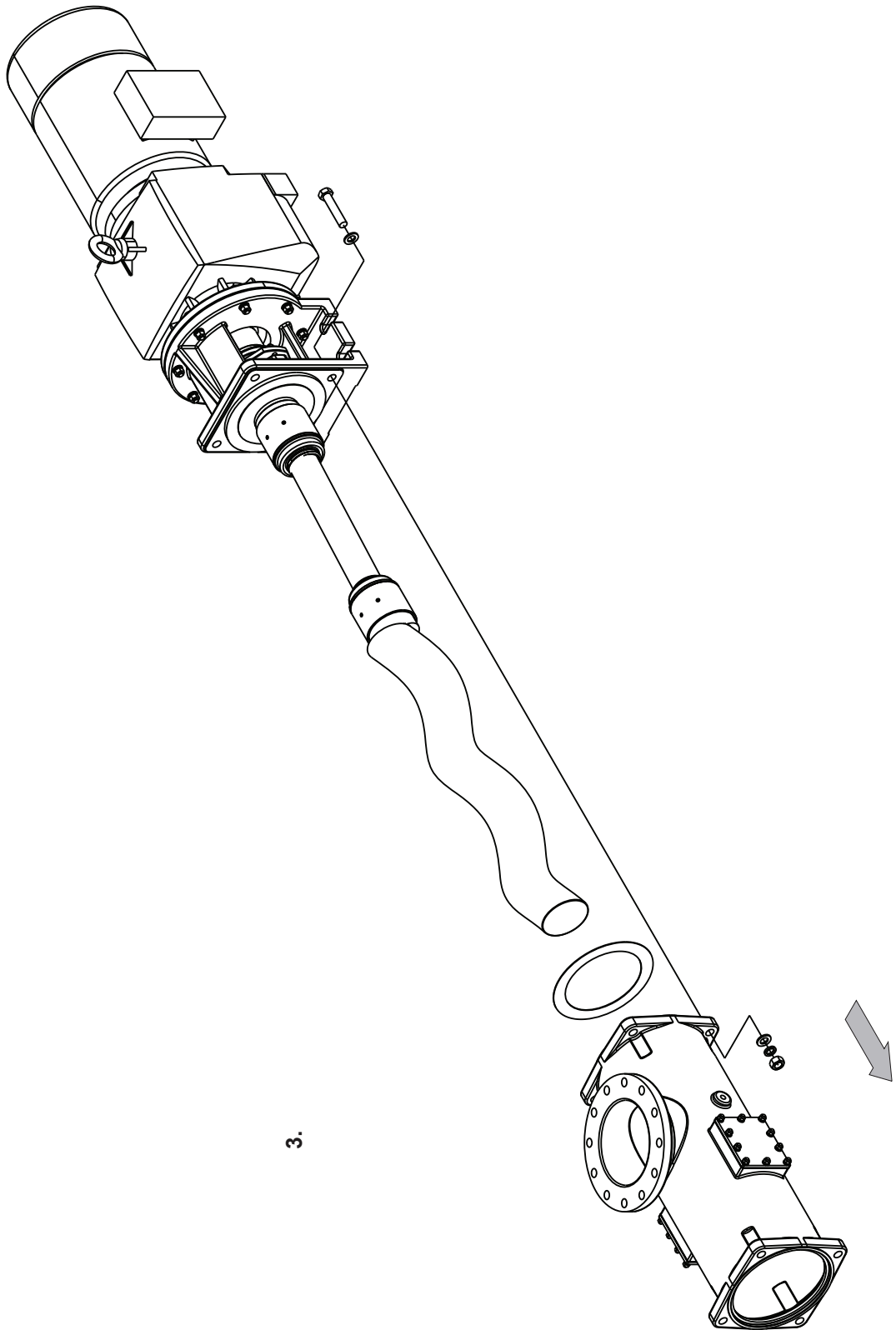

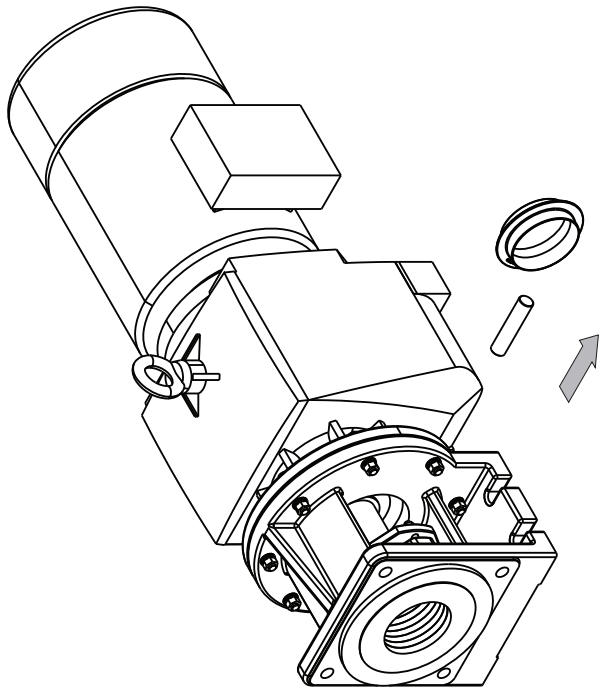

4.

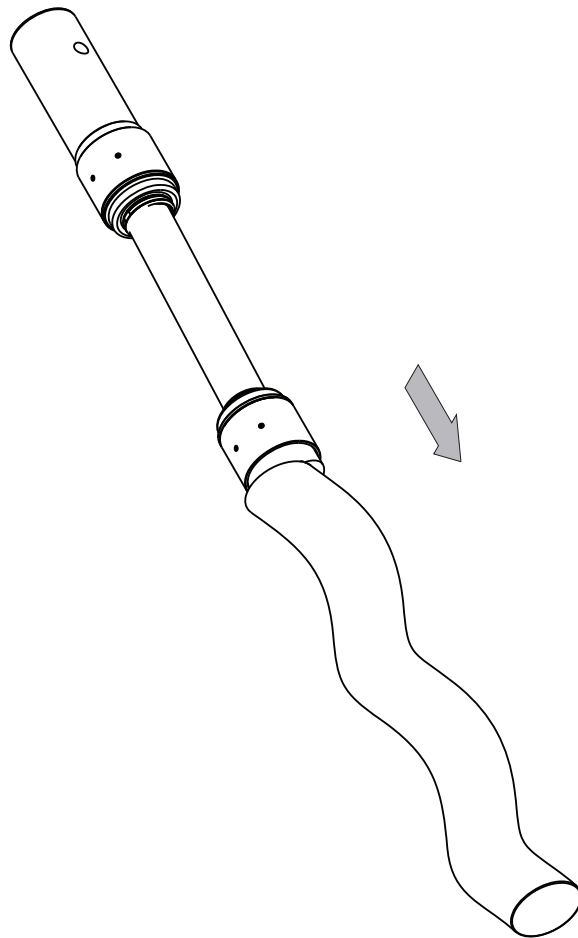

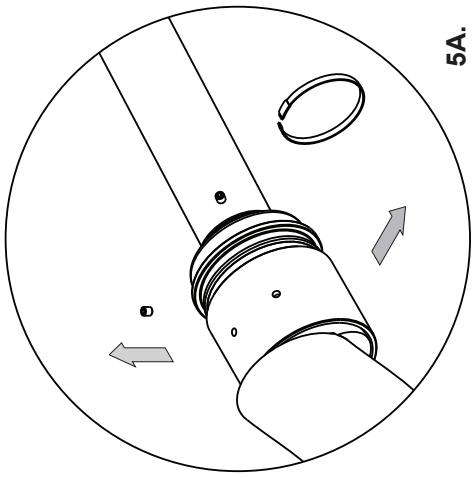

5A.

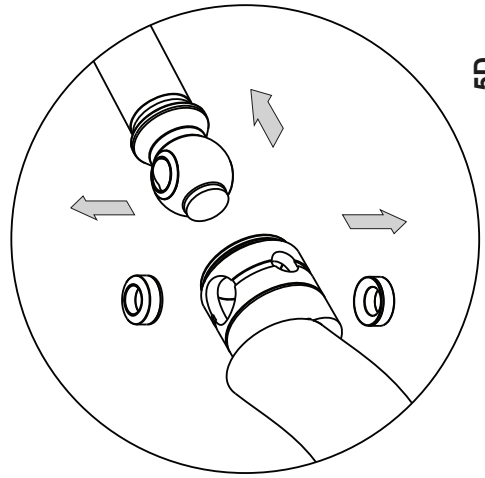

5D.

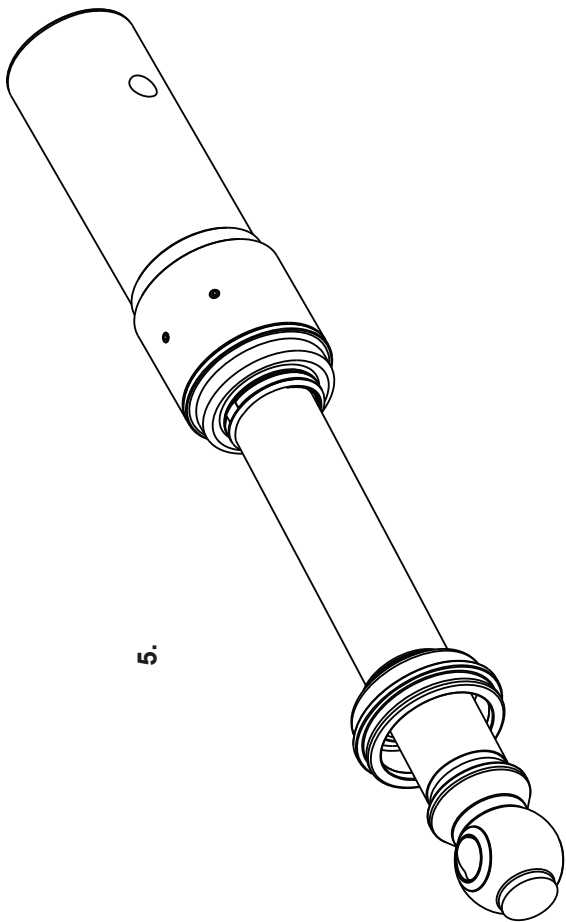

5.

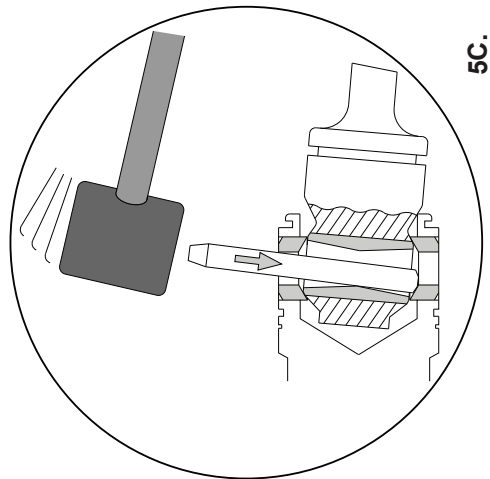

5C.

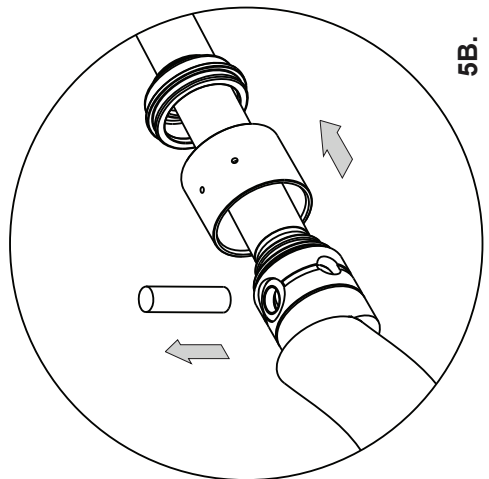

5B.

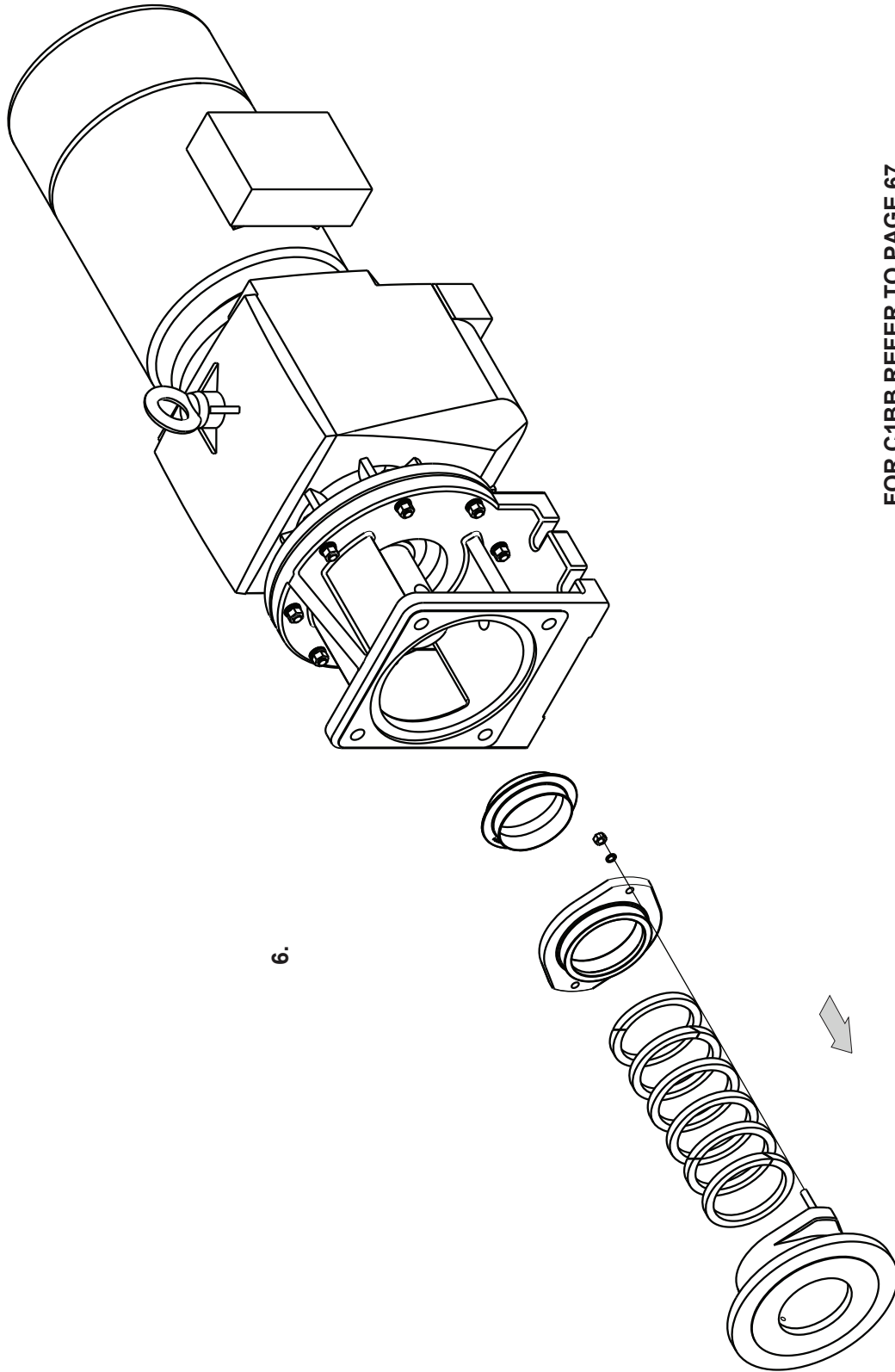

6.

FOR C1BB REFER TO PAGE 67

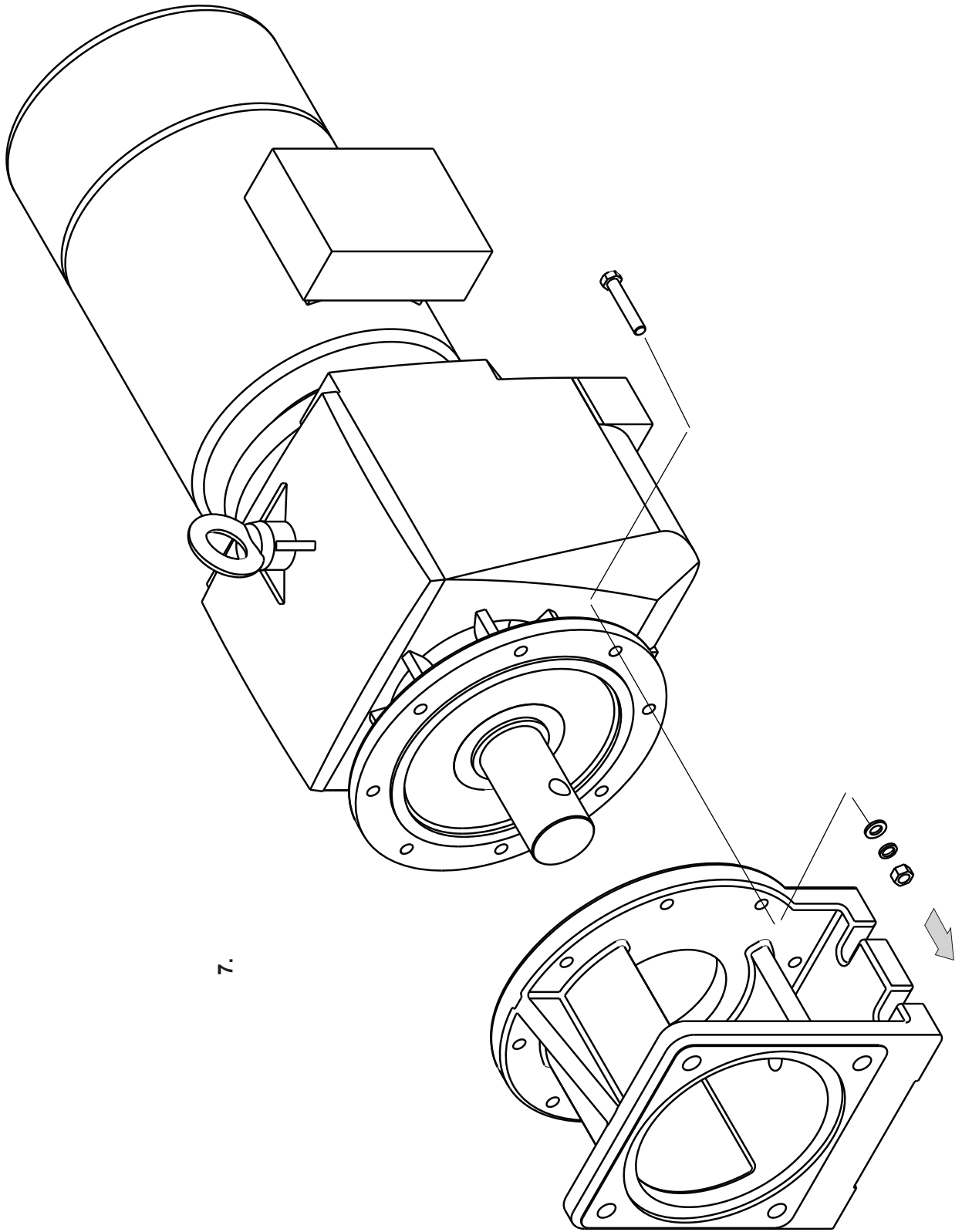

7.

Assembly

COMPACT RANGE
C1BB, C1CA & C1DA

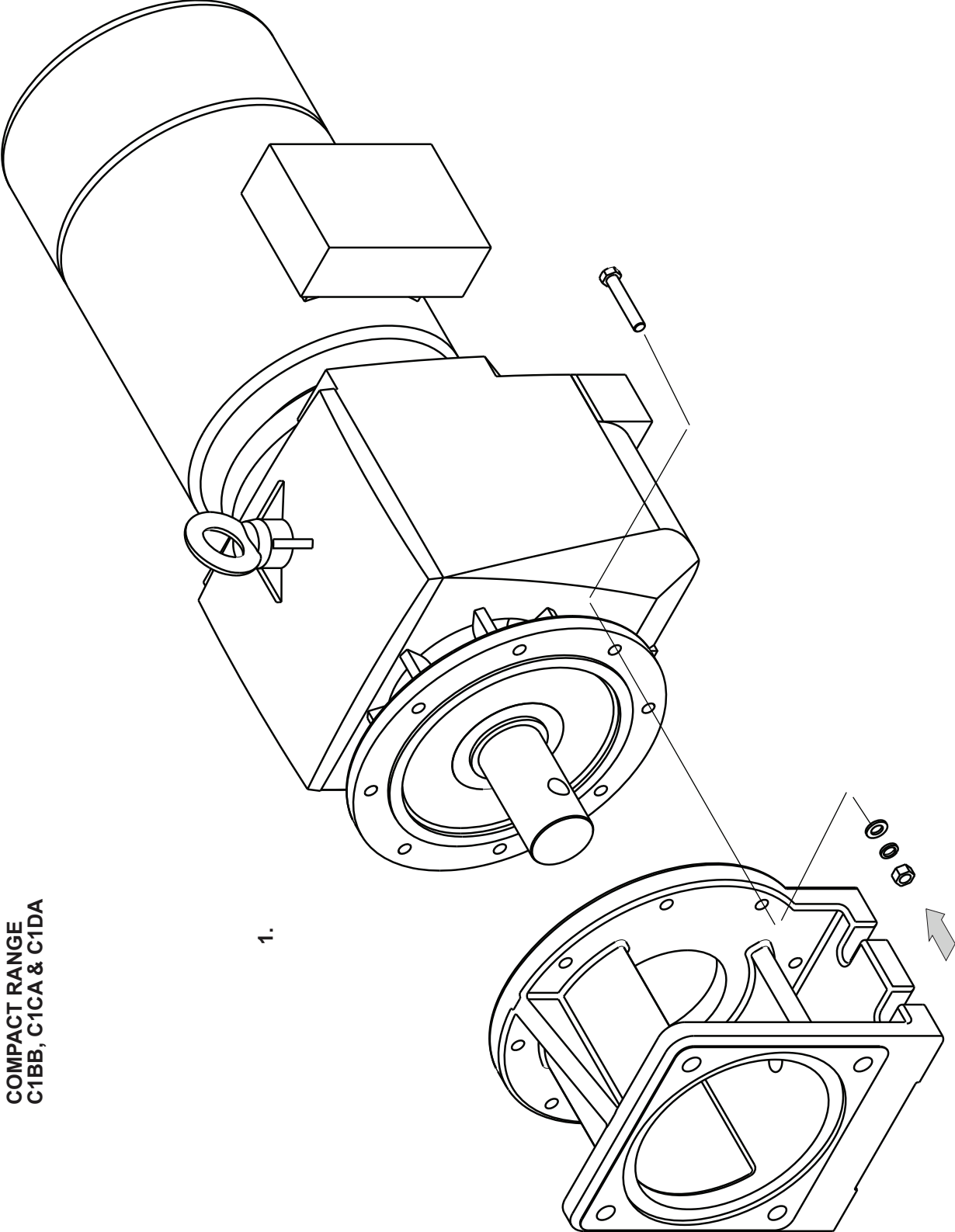

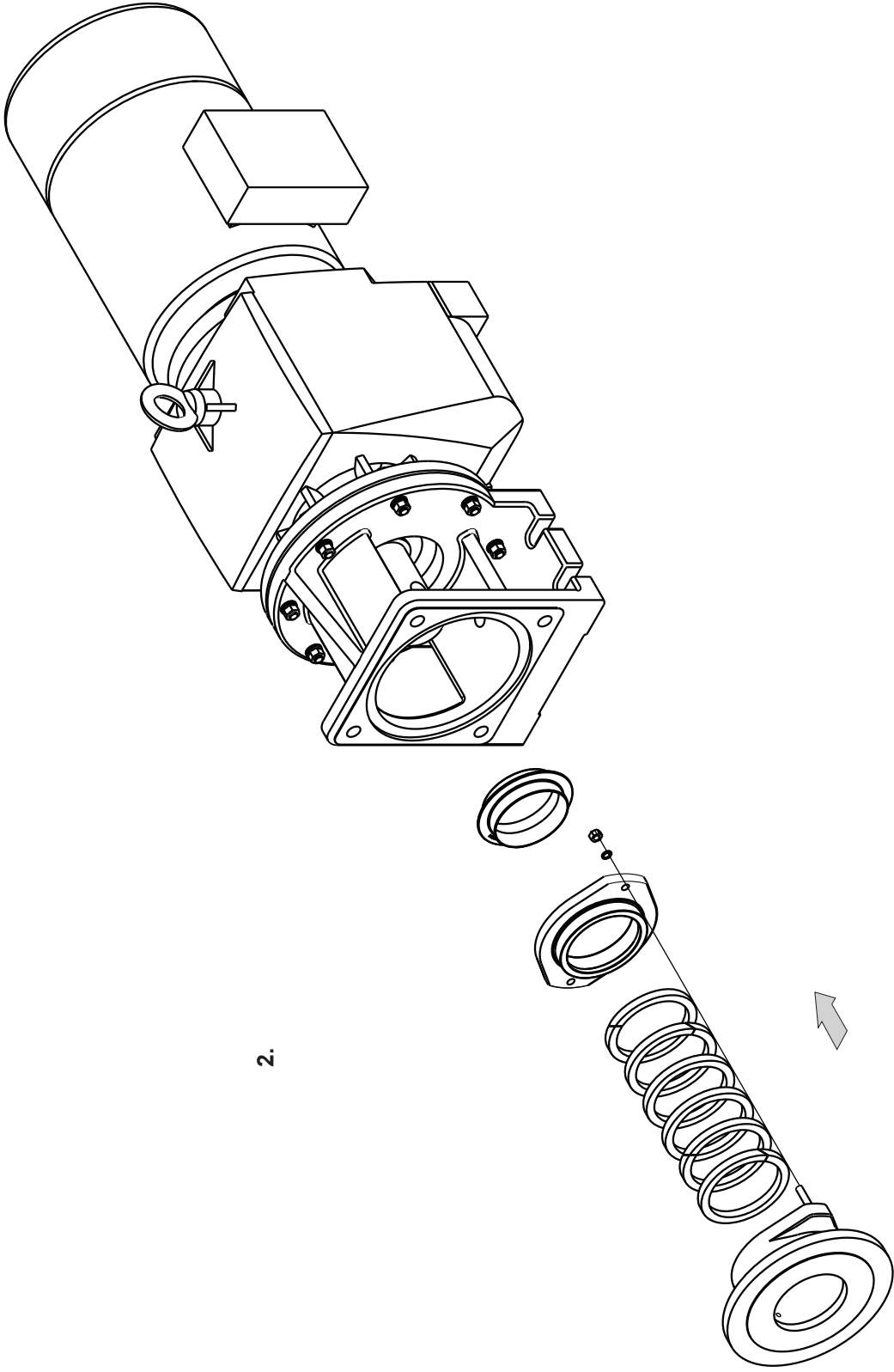

2.

FOR C1BB REFER TO SECTION 4, PAGE 41

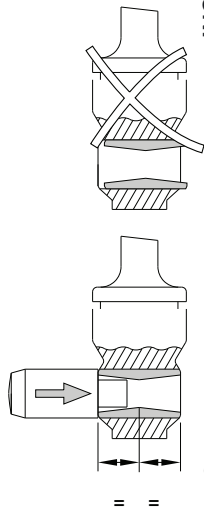
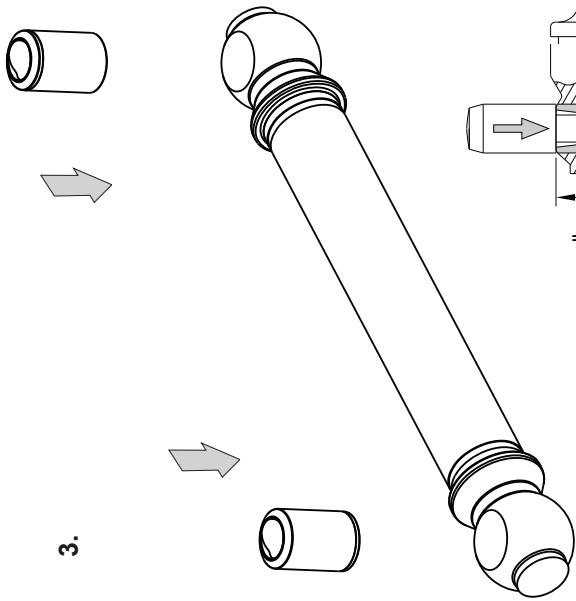

CORRECT

INCORRECT

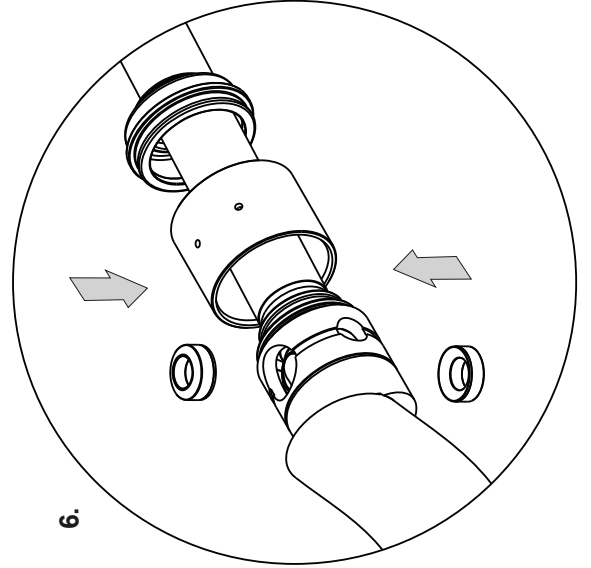
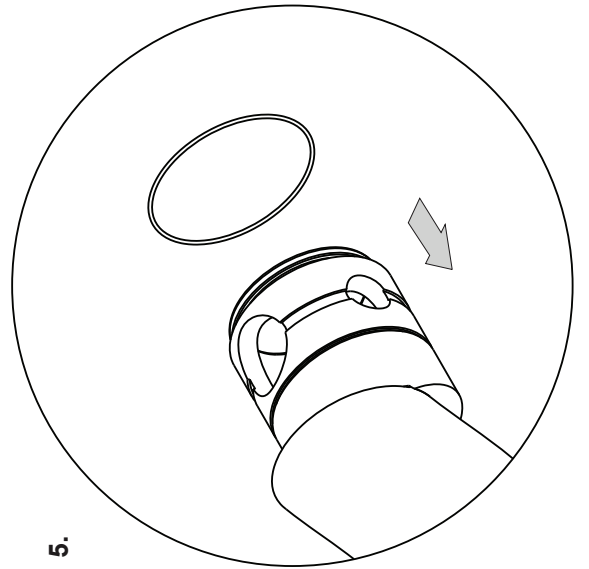
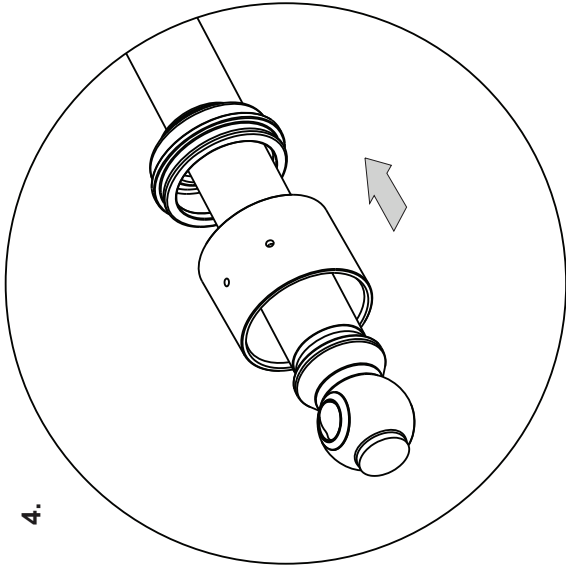

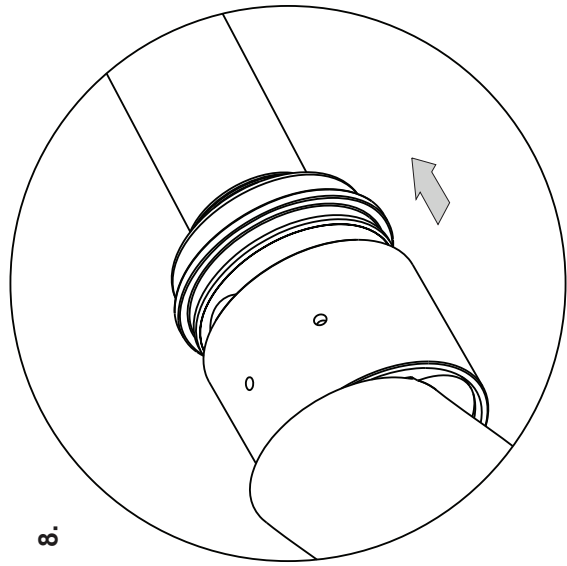

8.

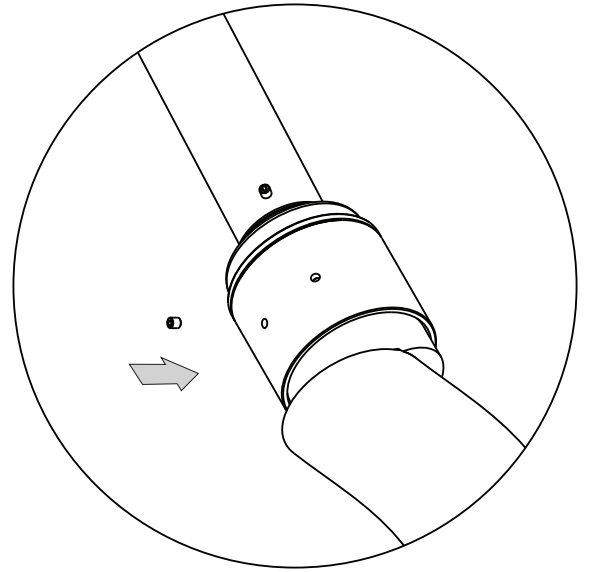

11.

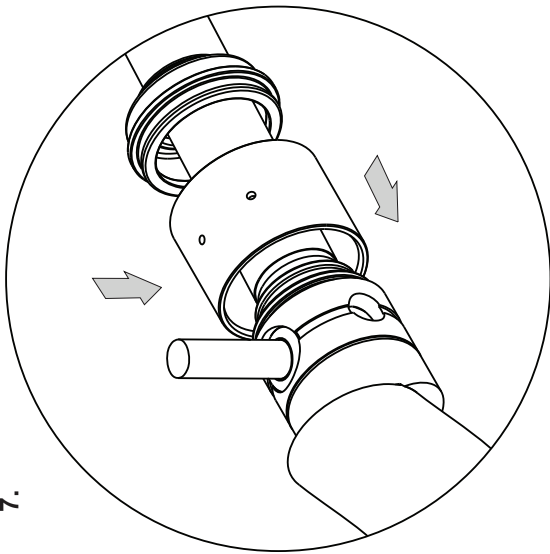

7.

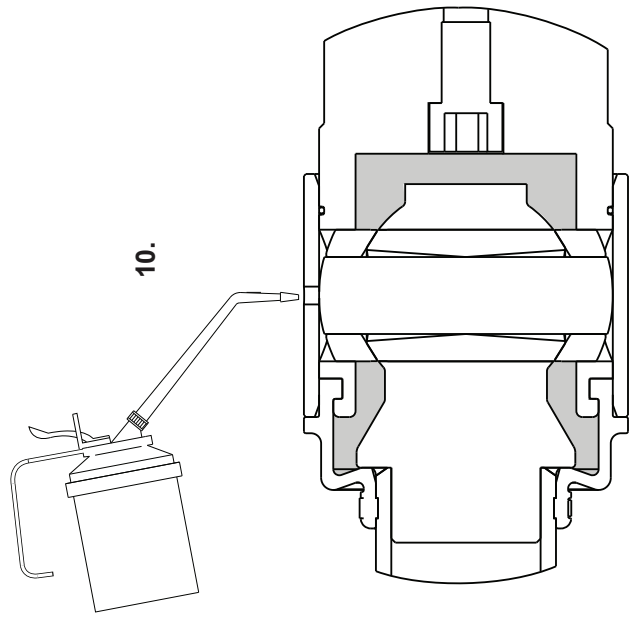

10.

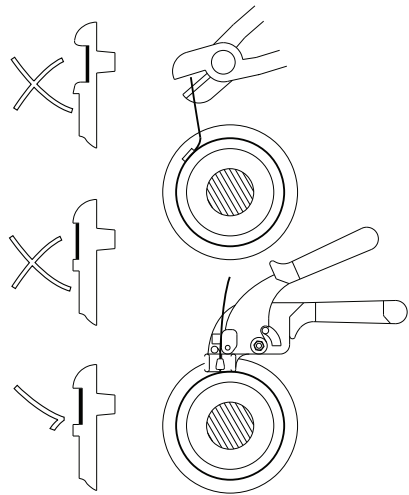

9.

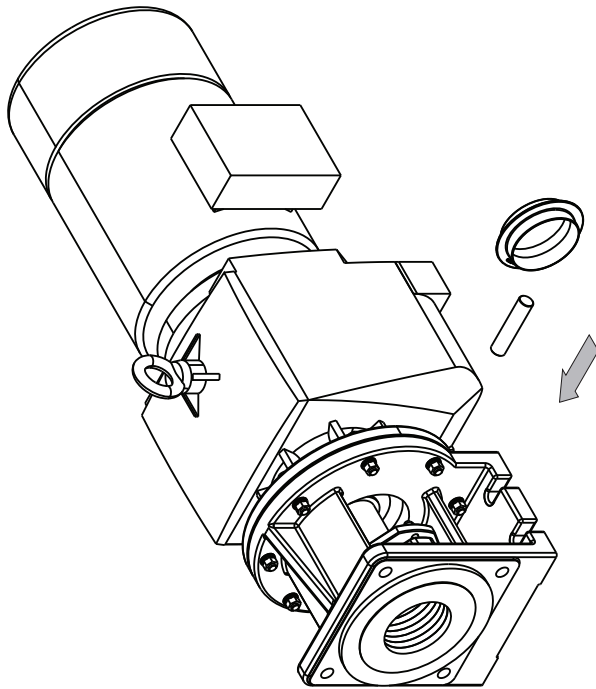

12.

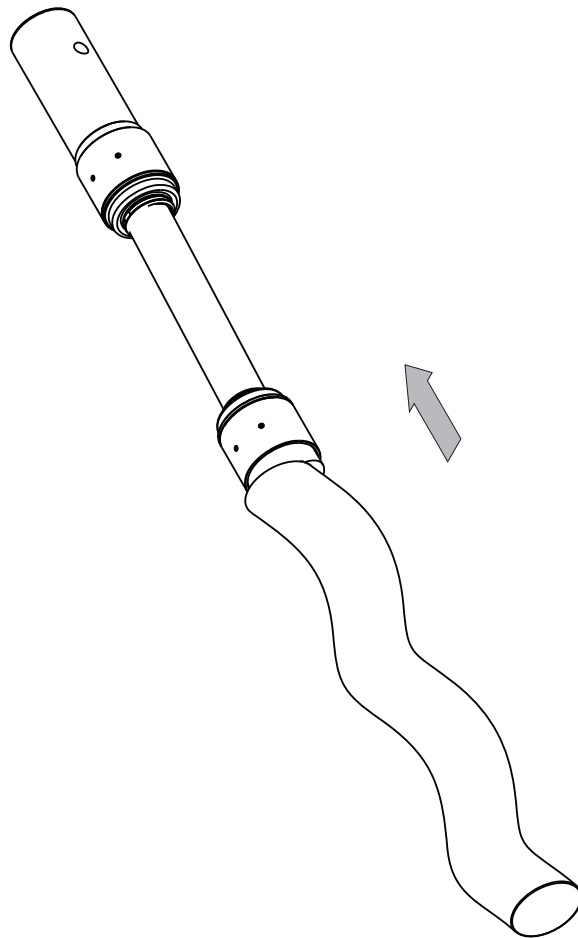

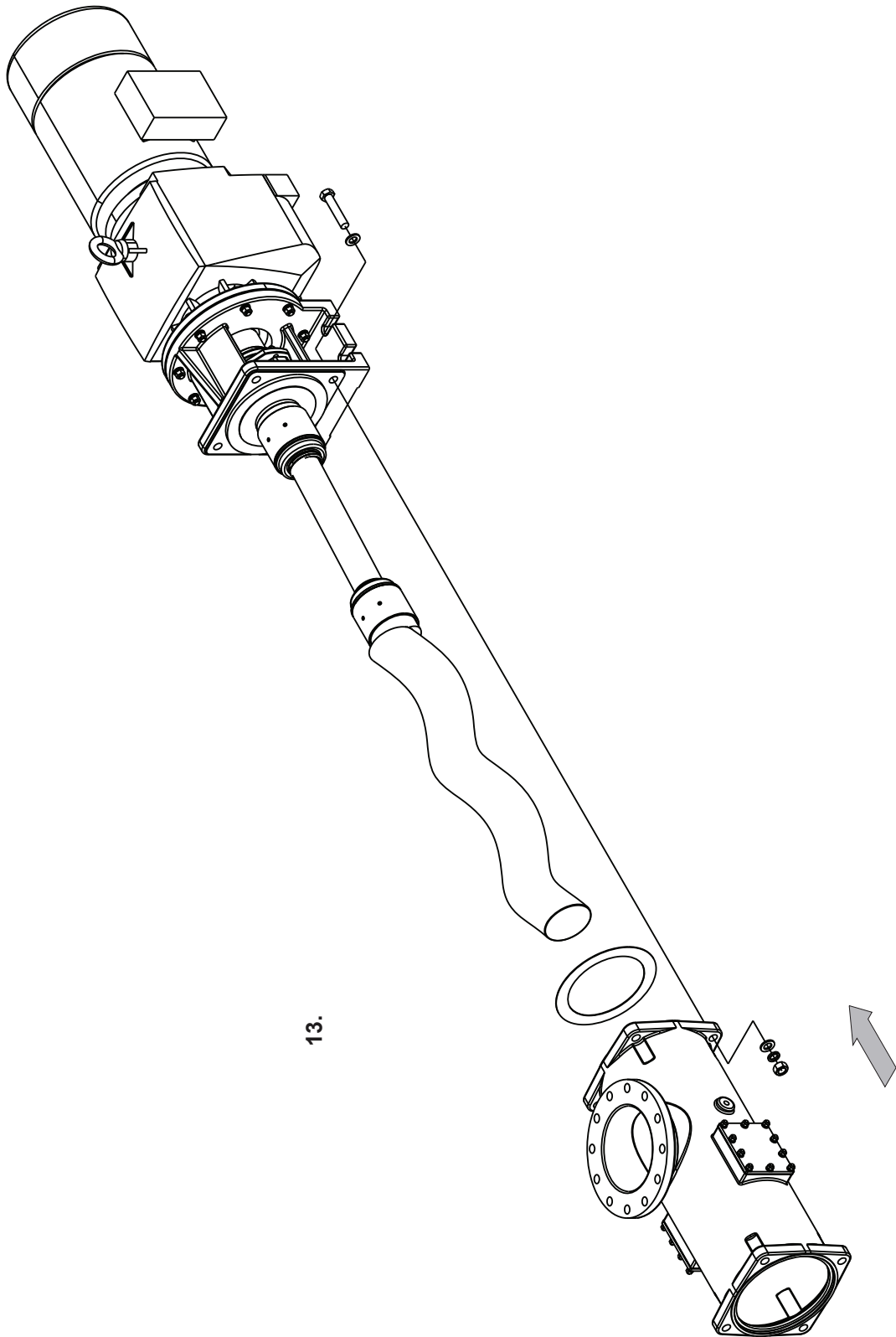

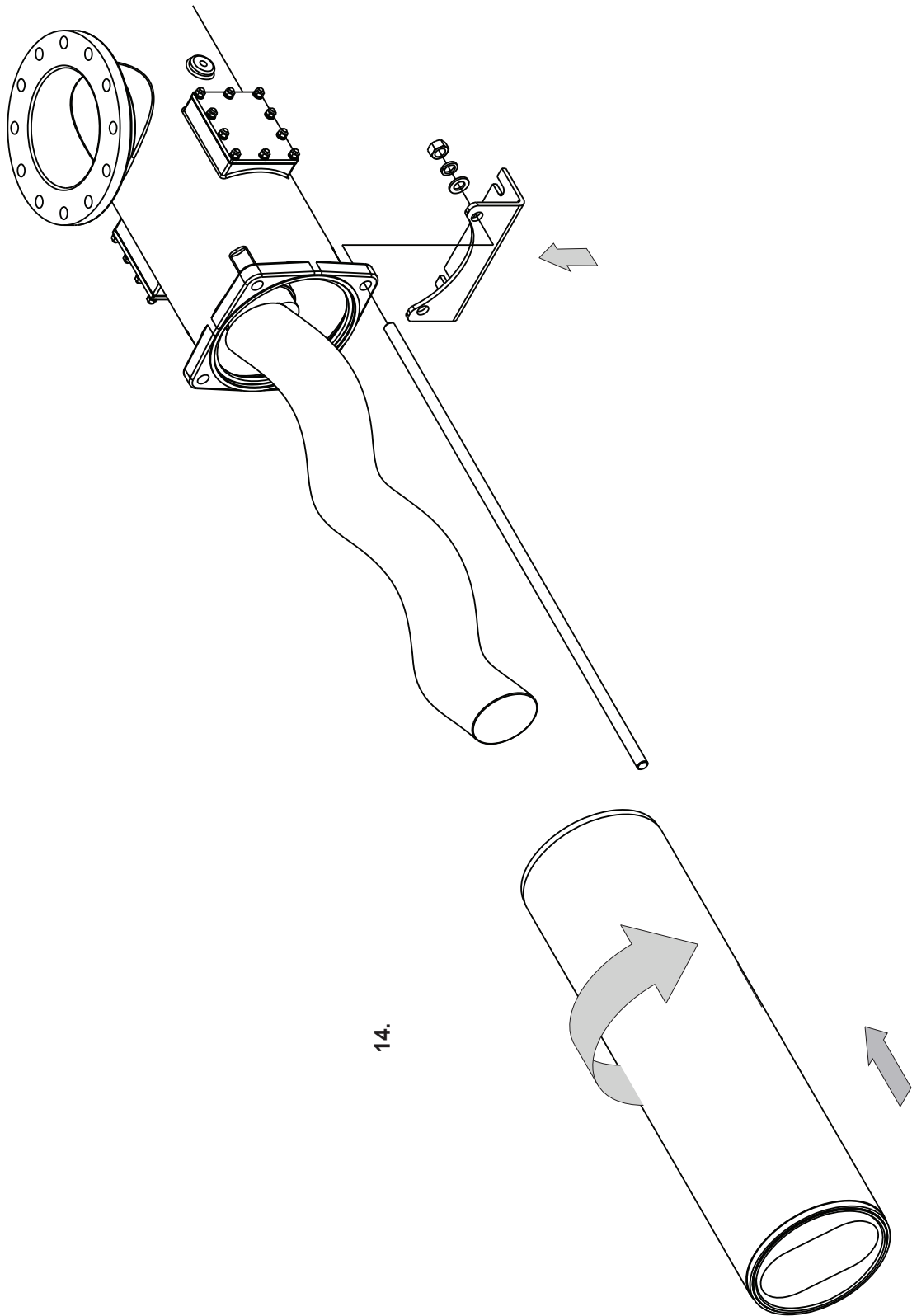

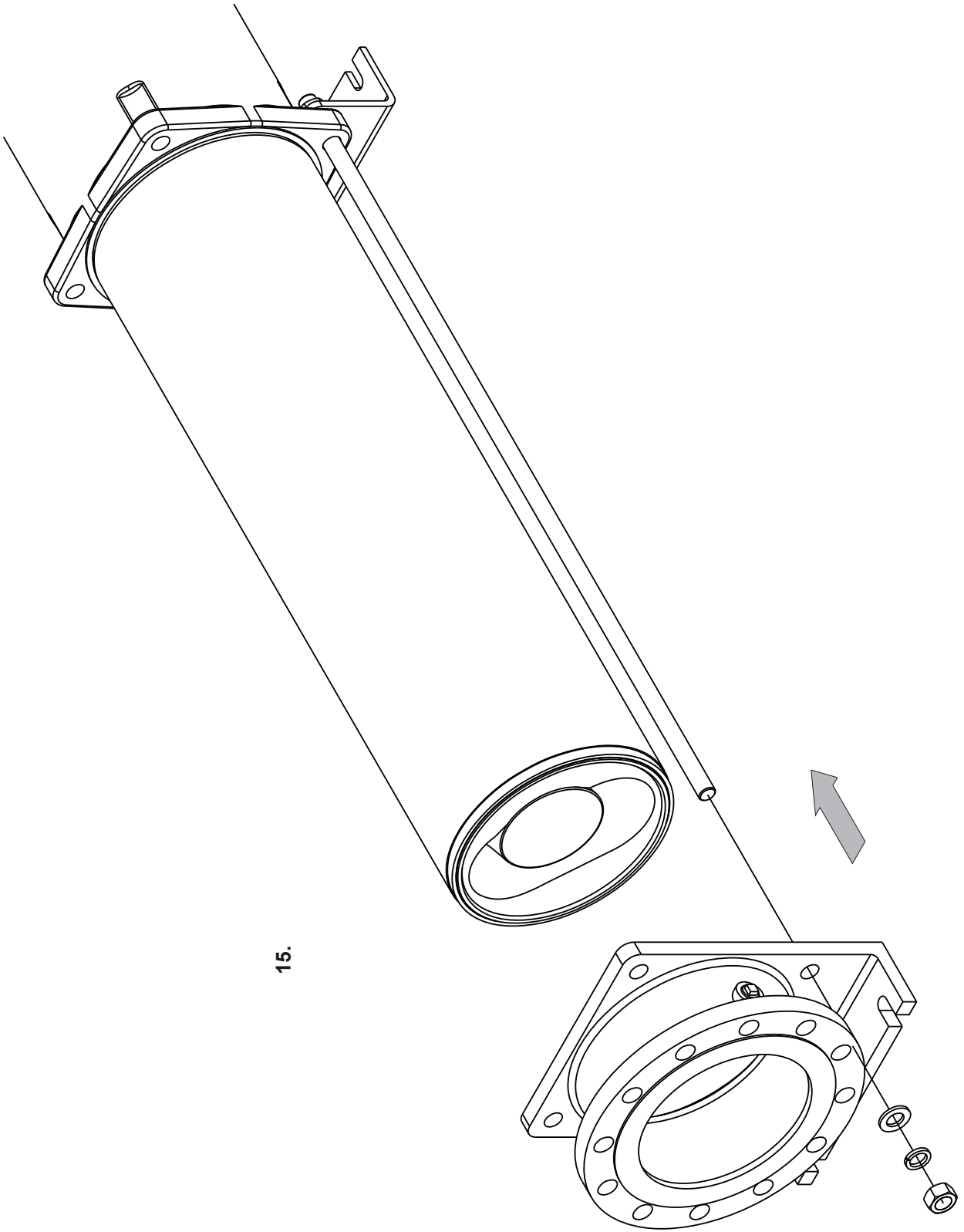

Dismantling - C1CB and C1CK

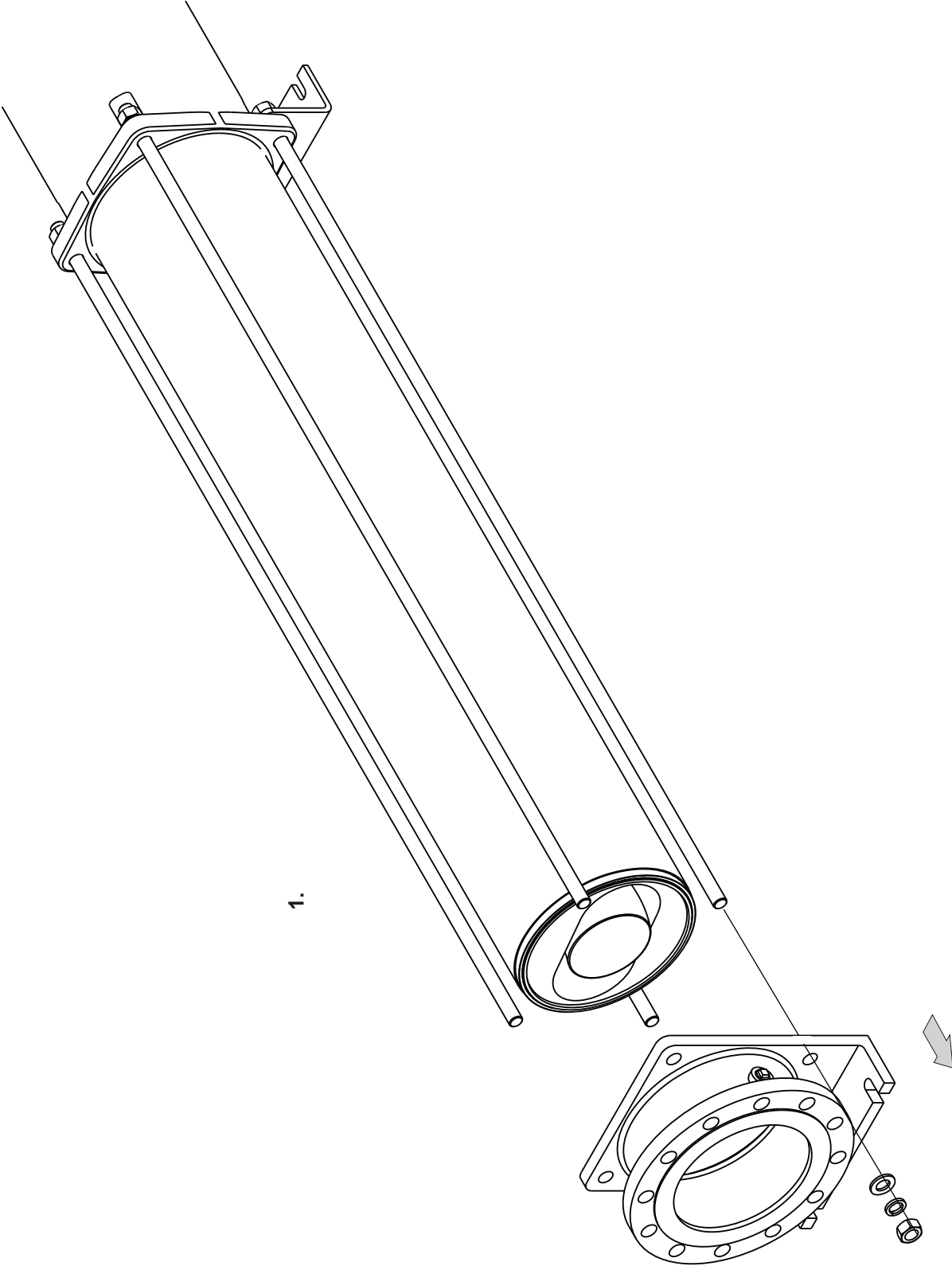

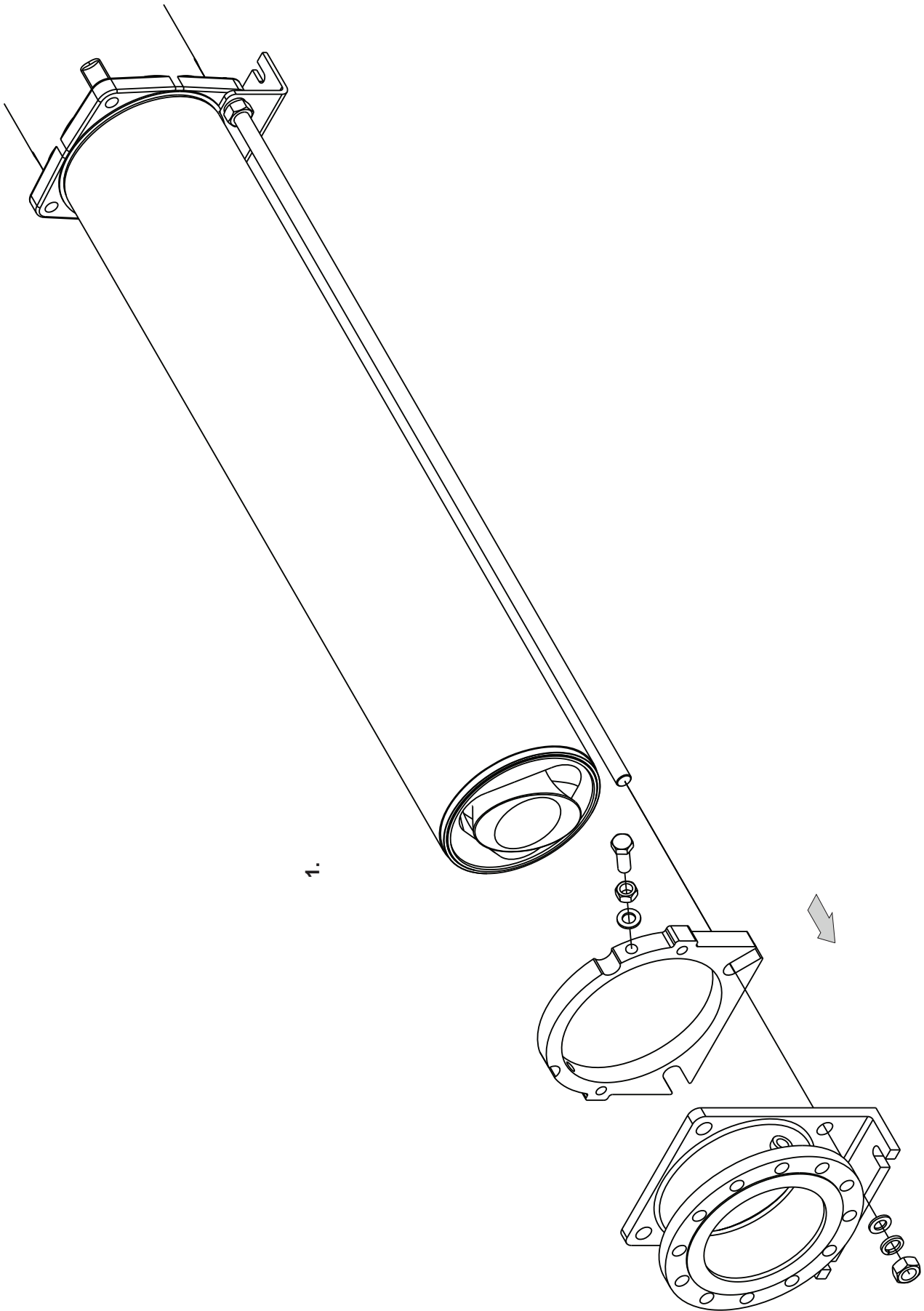

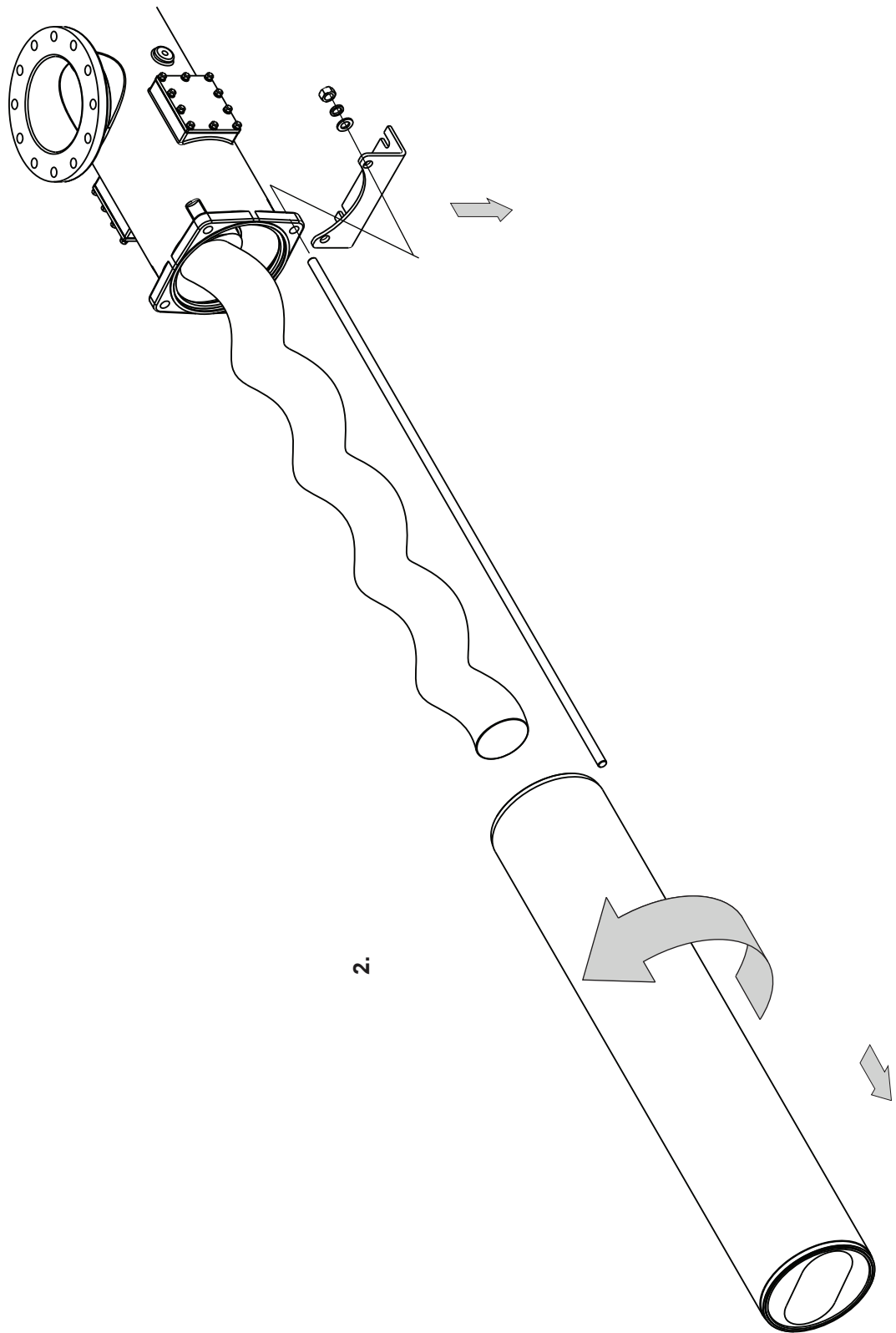

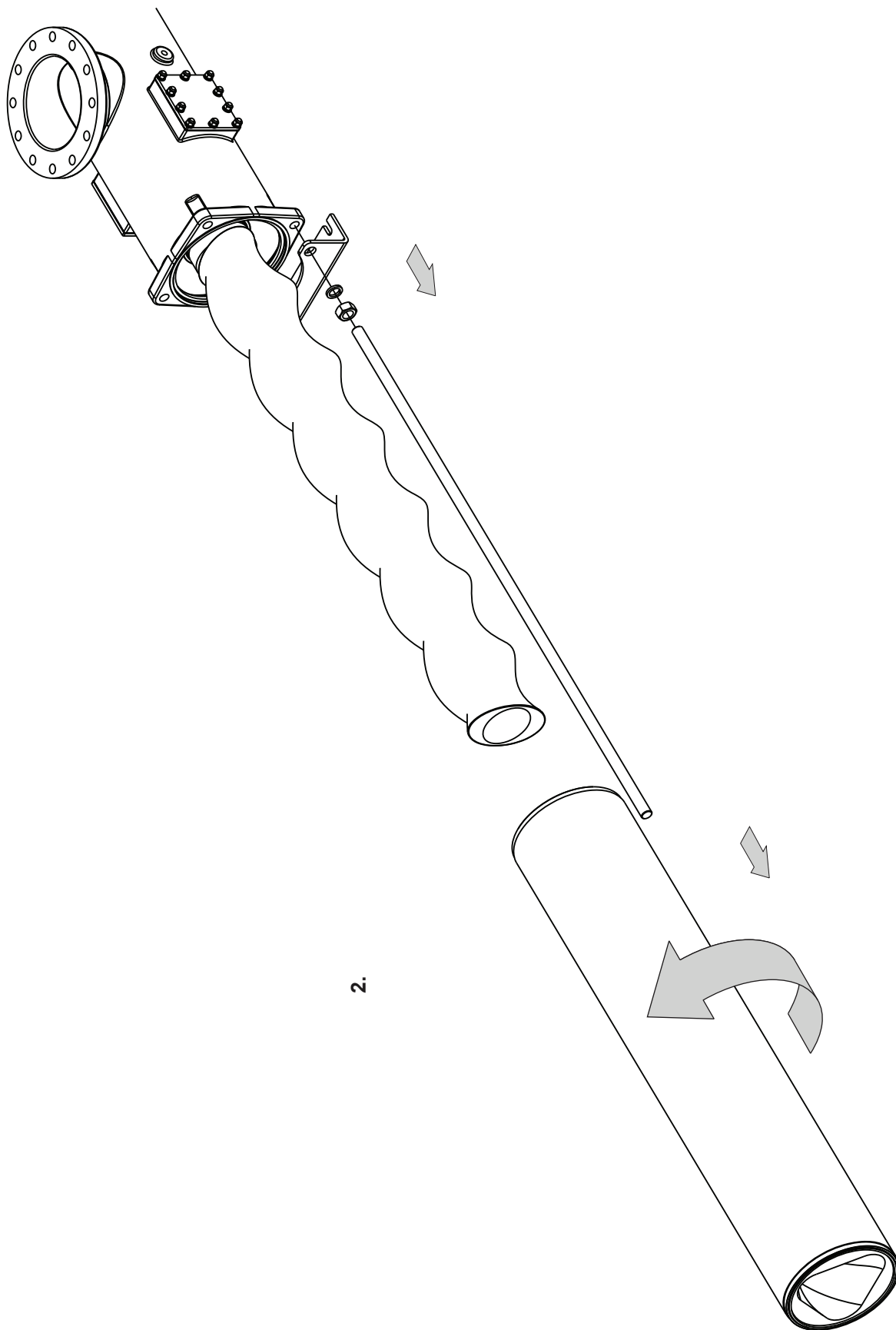

2.

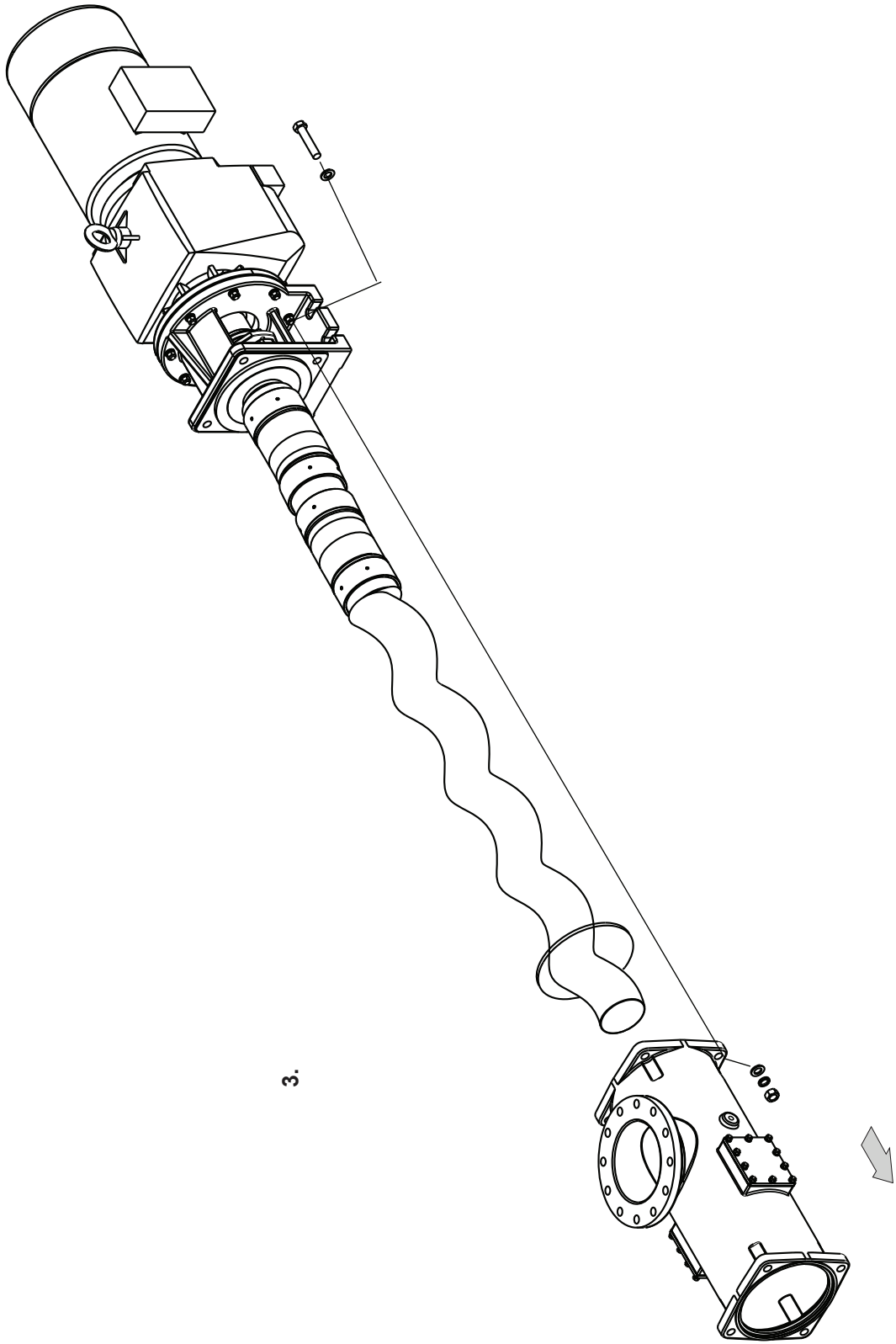

3.

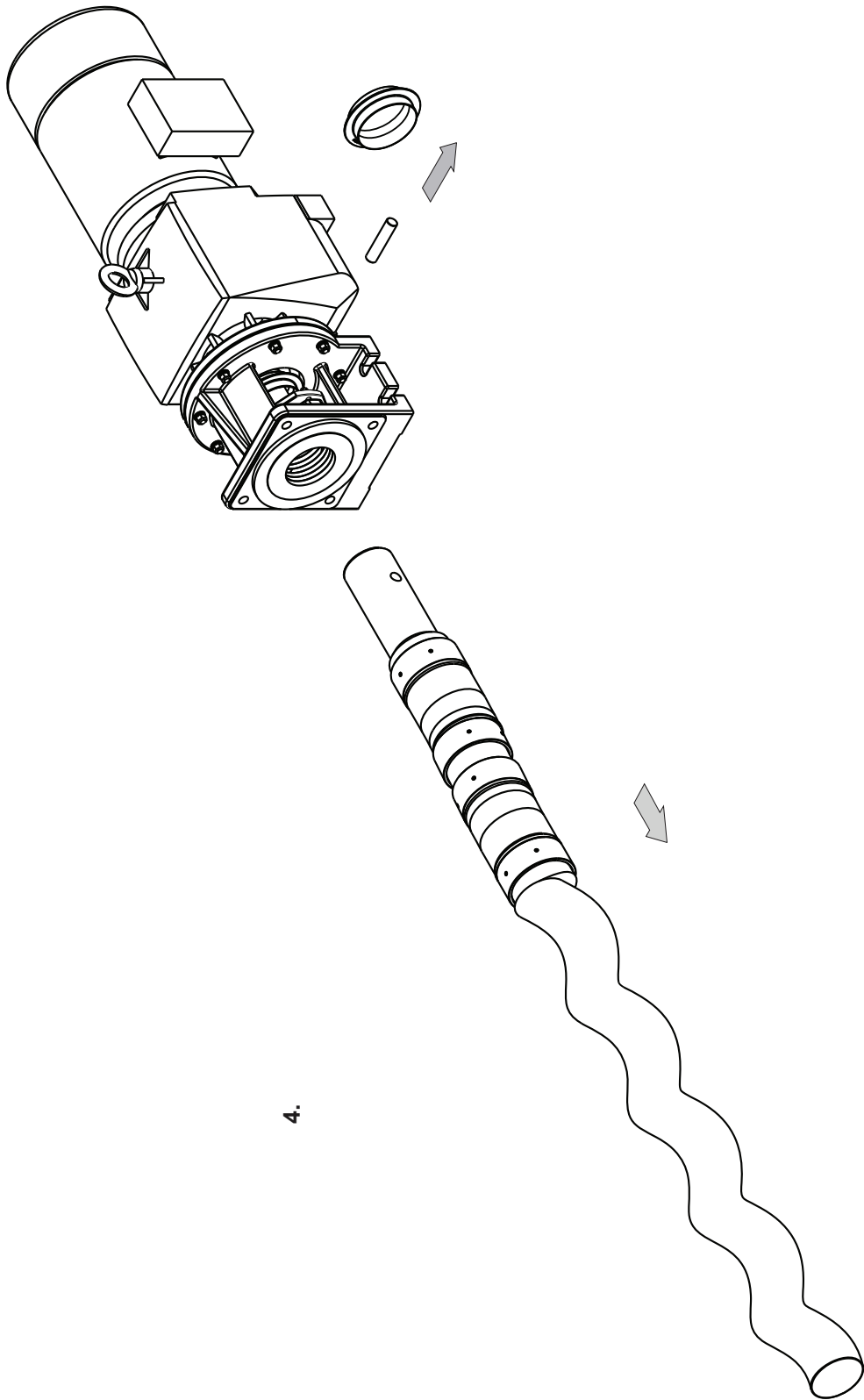

4.

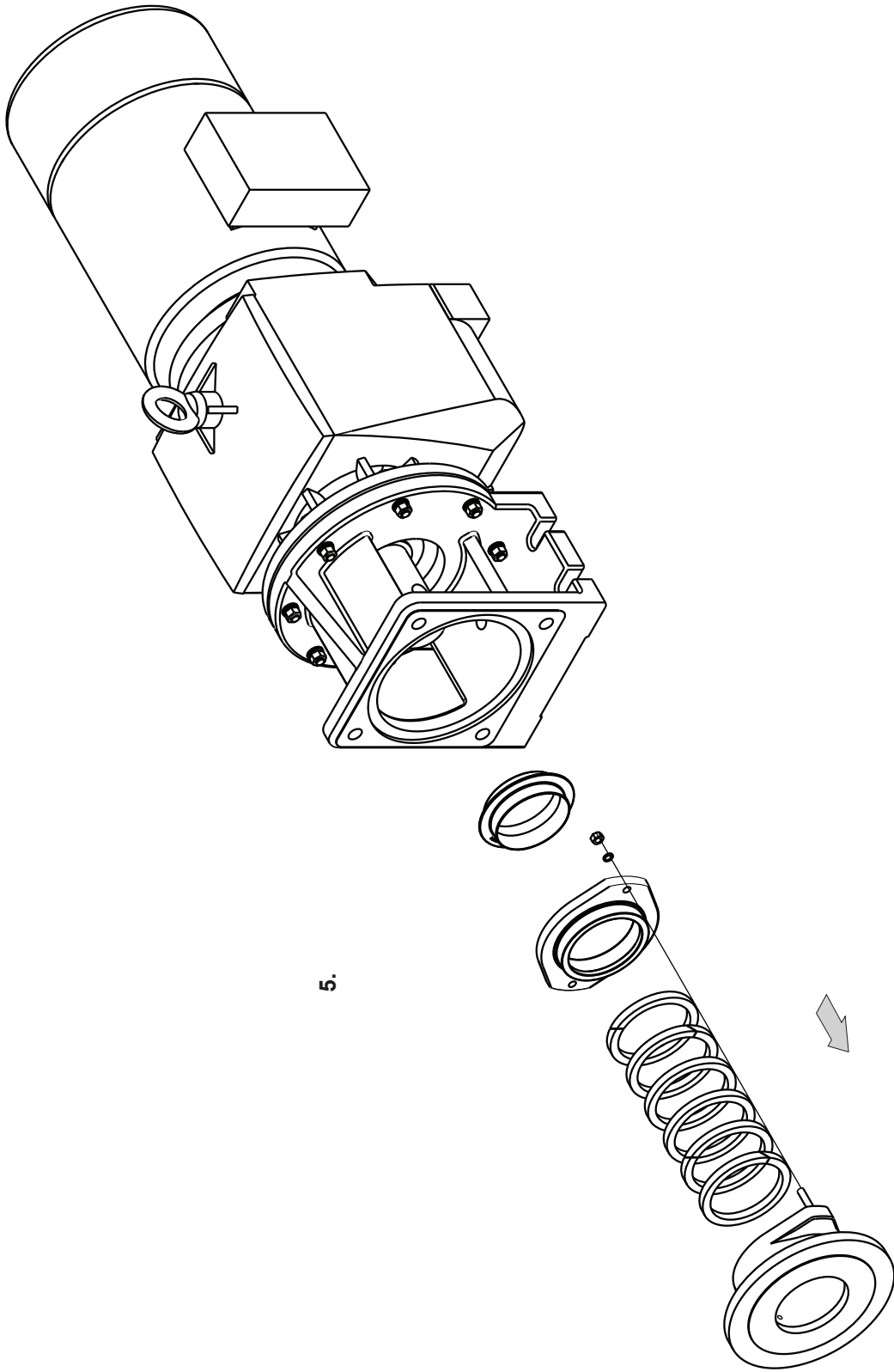

5.

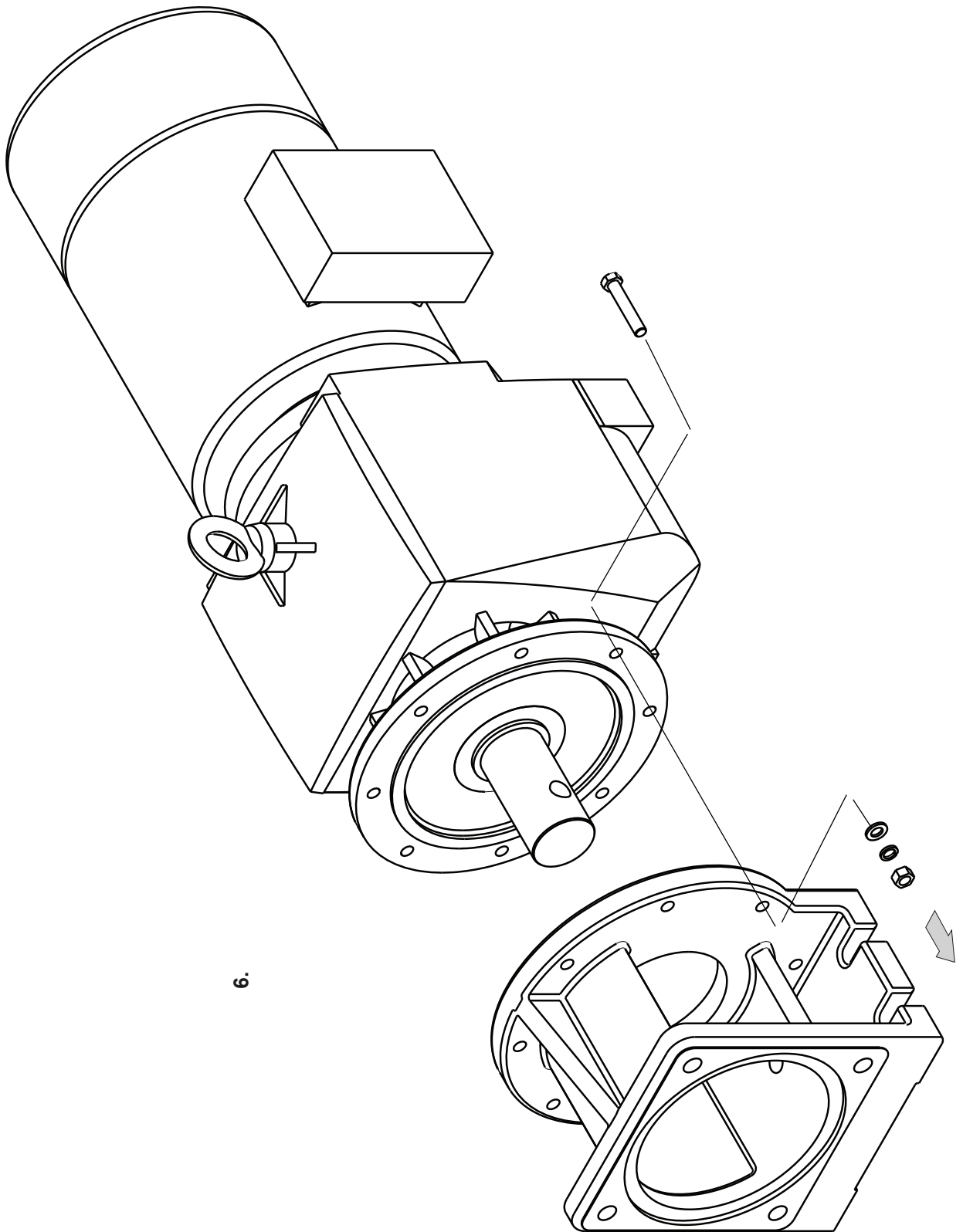

6.

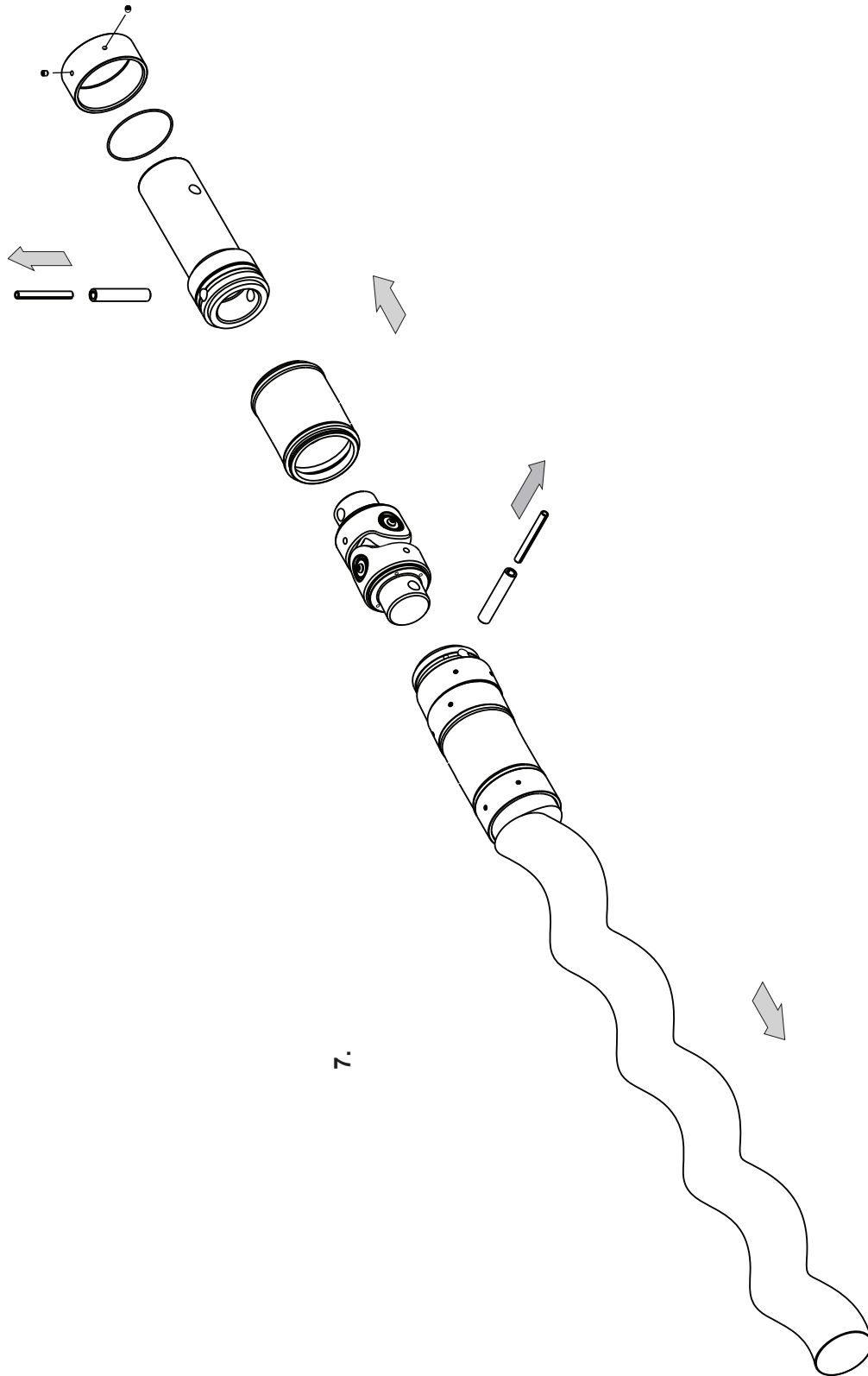

7.

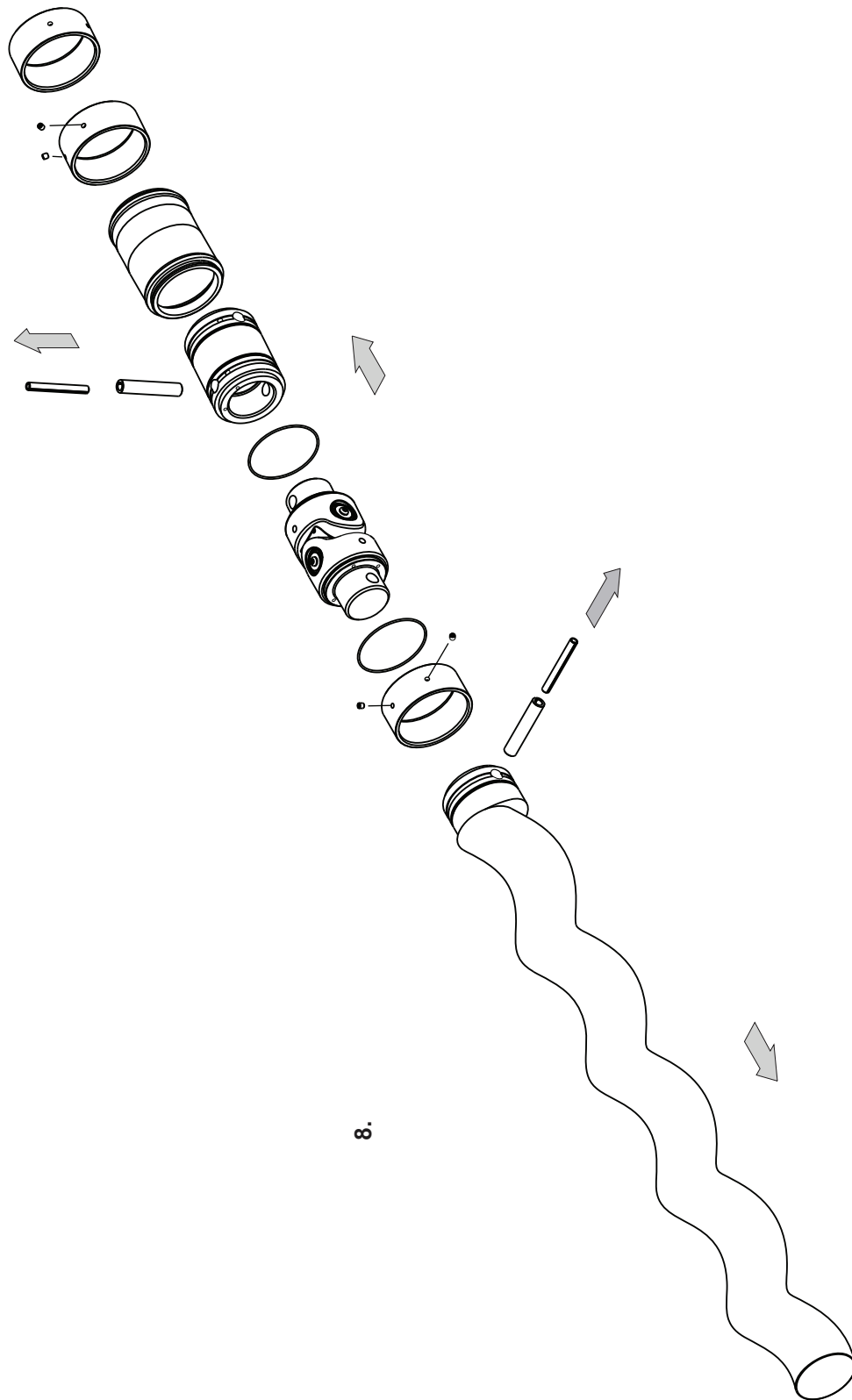

8.

9.

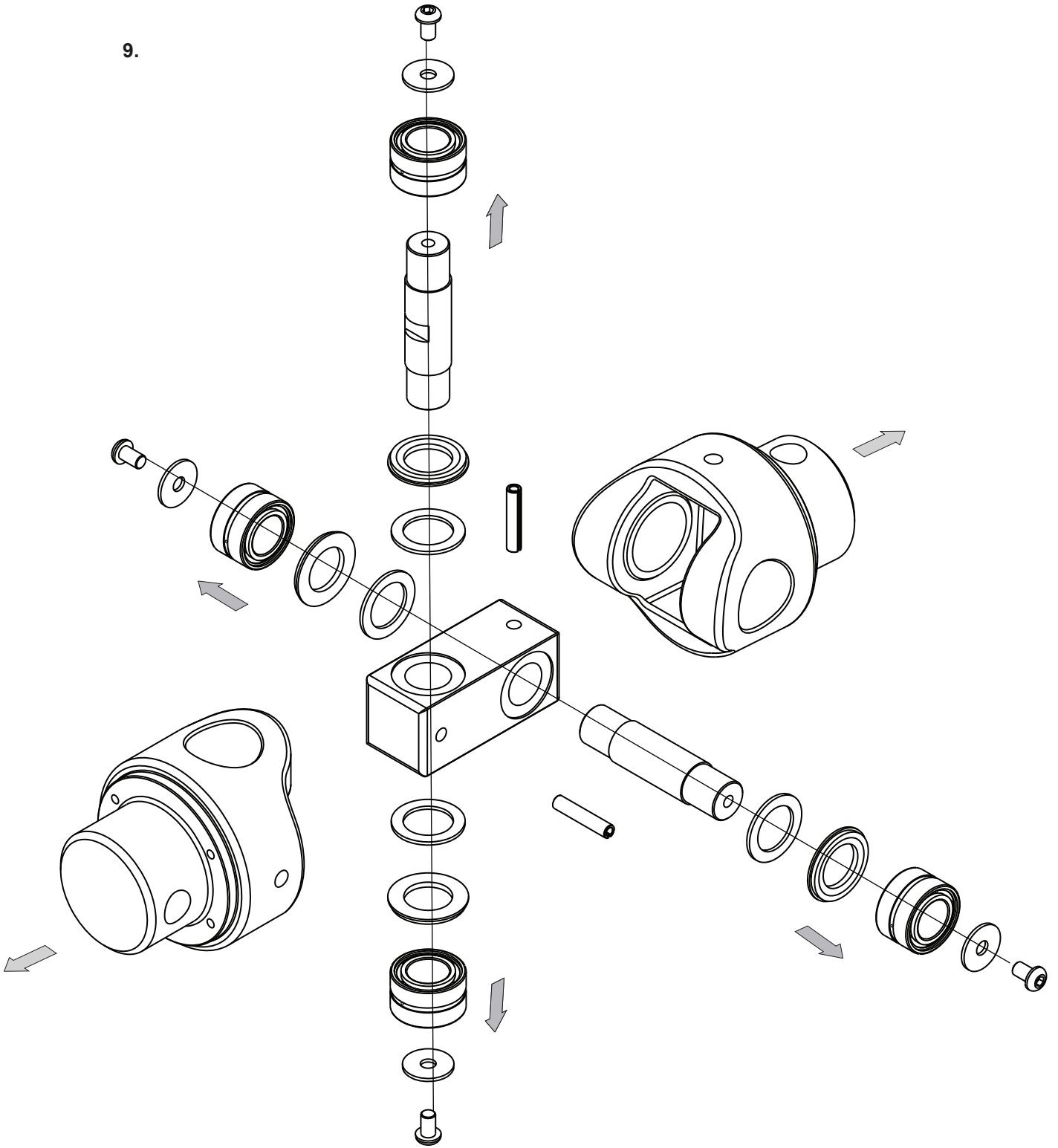

Assembly - C1CB and C1CK

1.

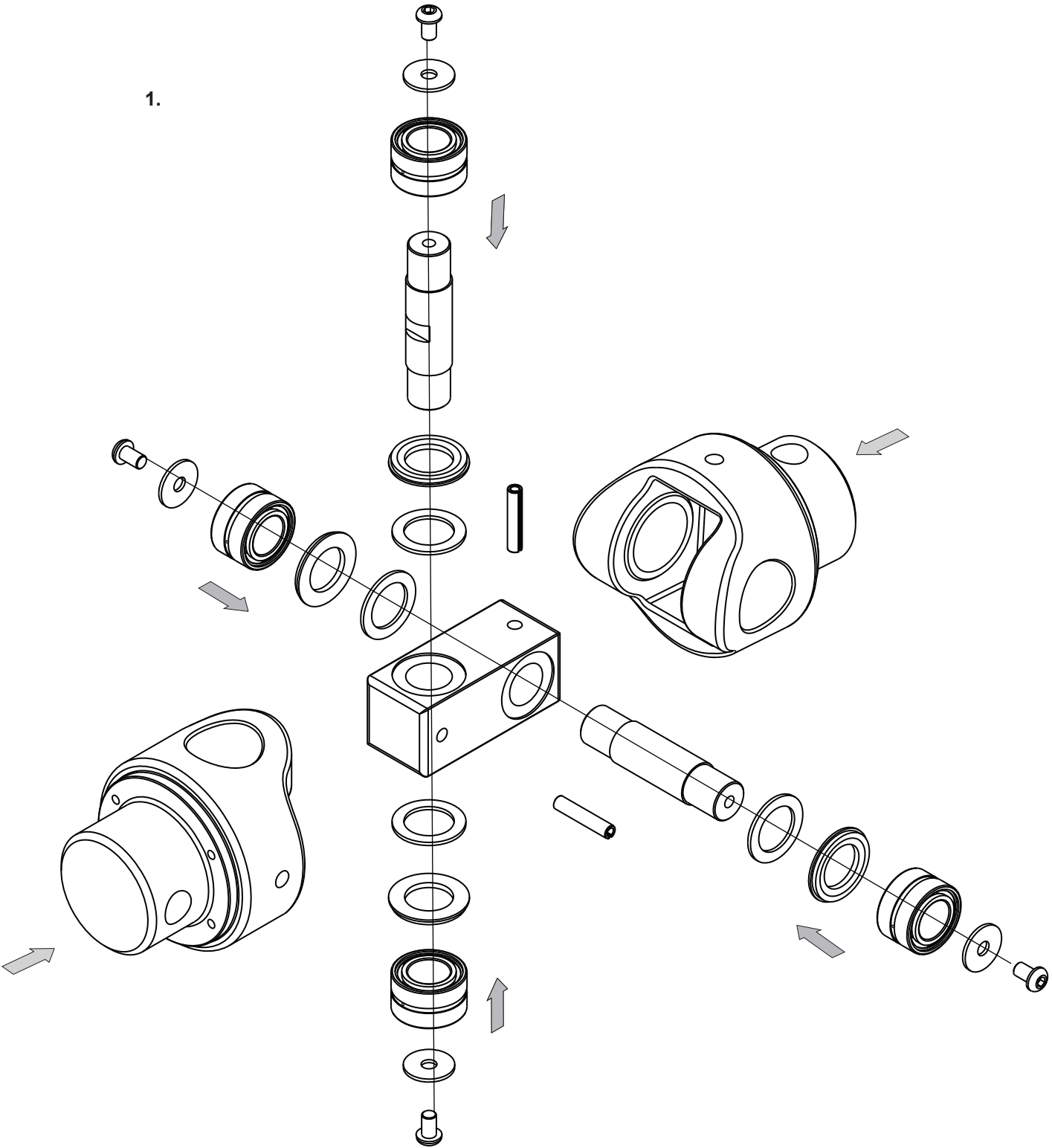

PIN ORIENTATION

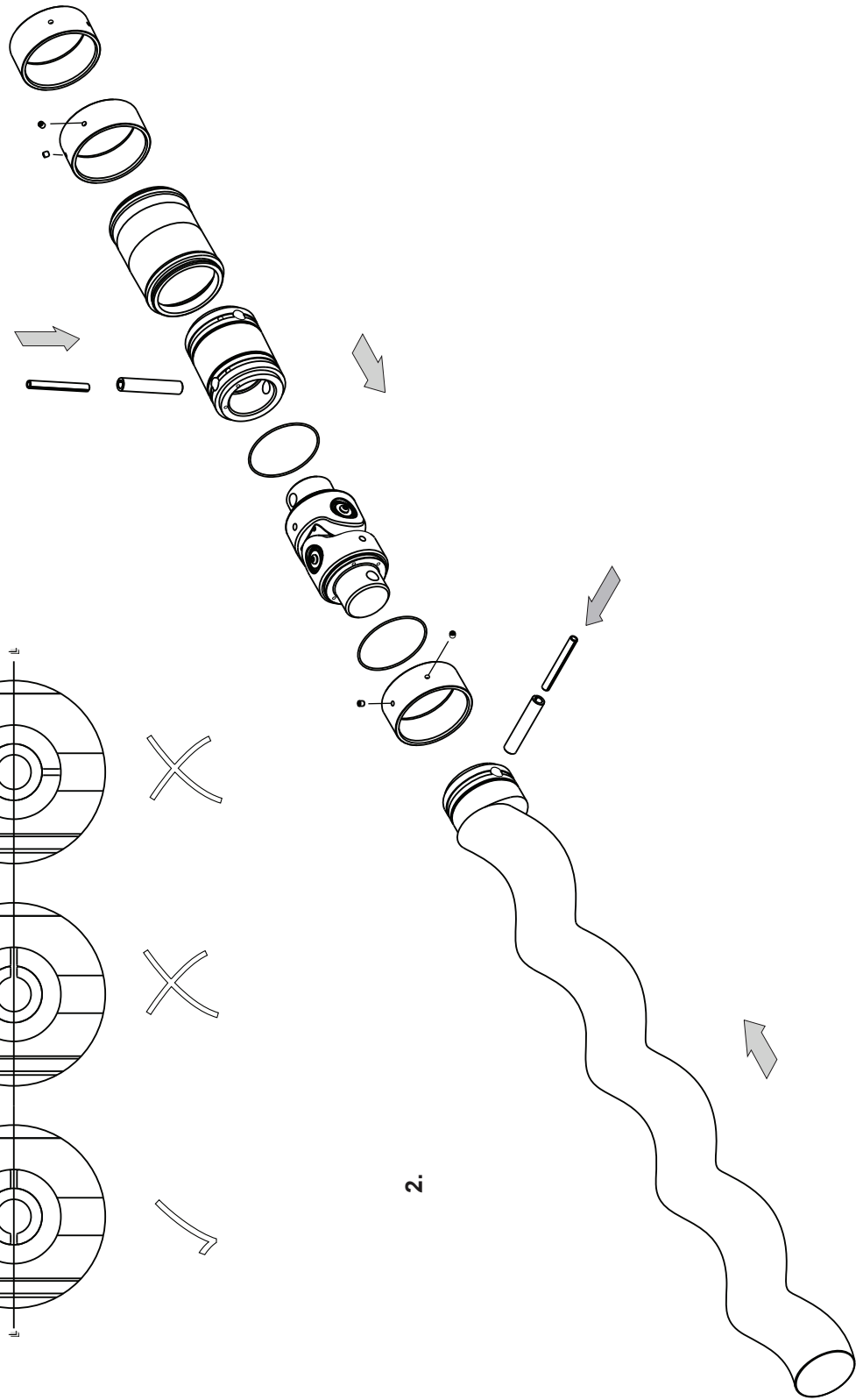
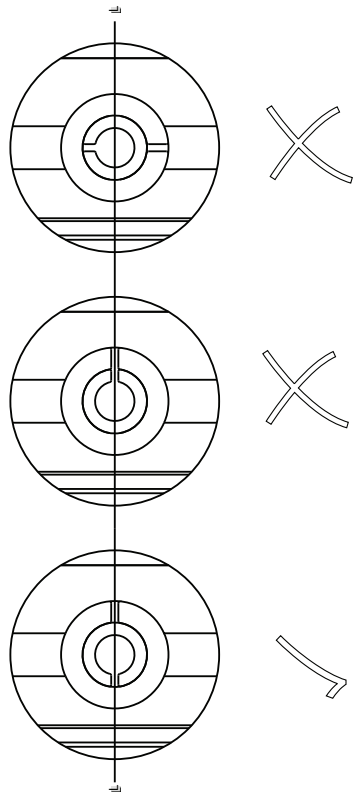

PIN ORIENTATION

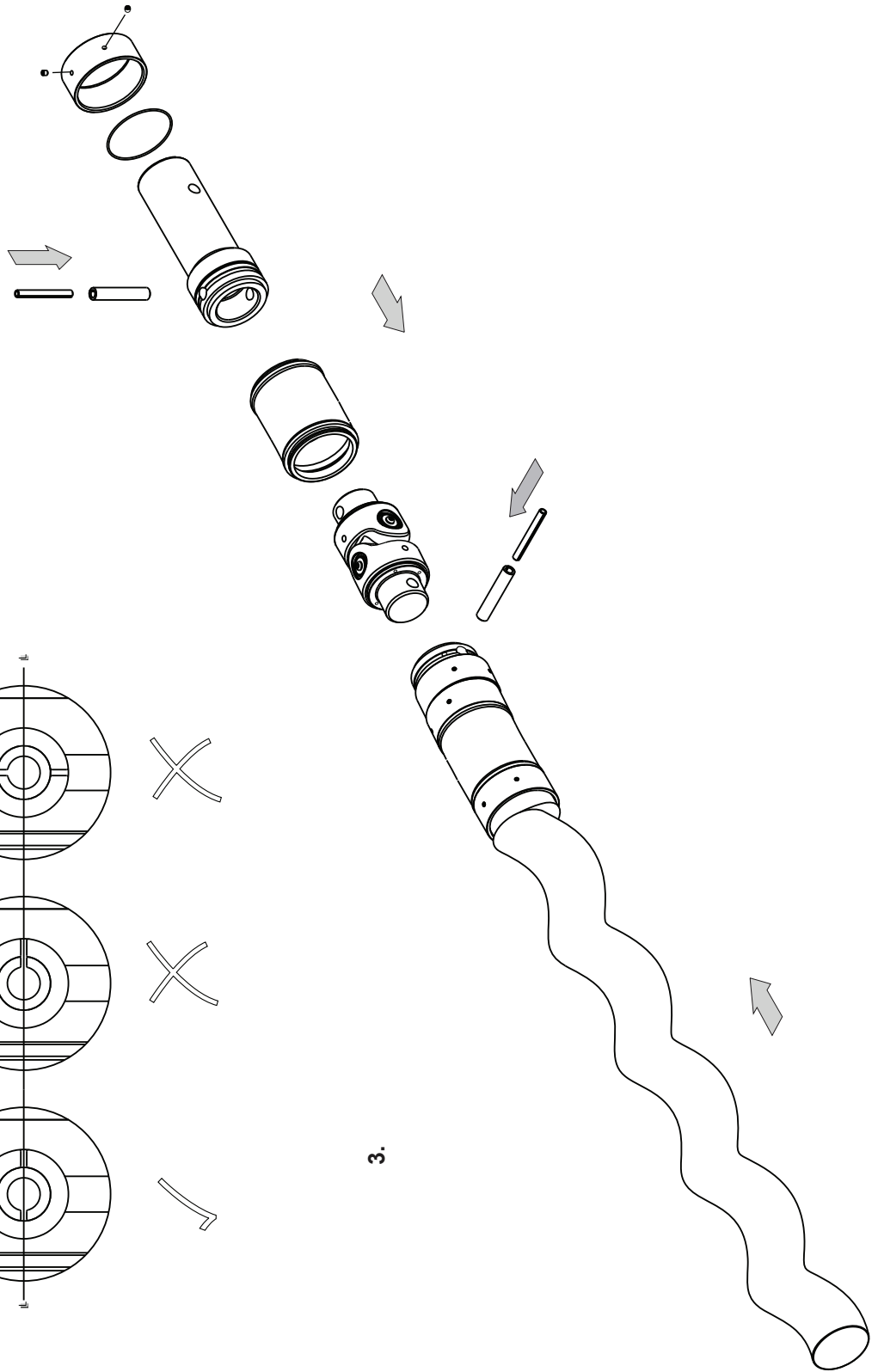
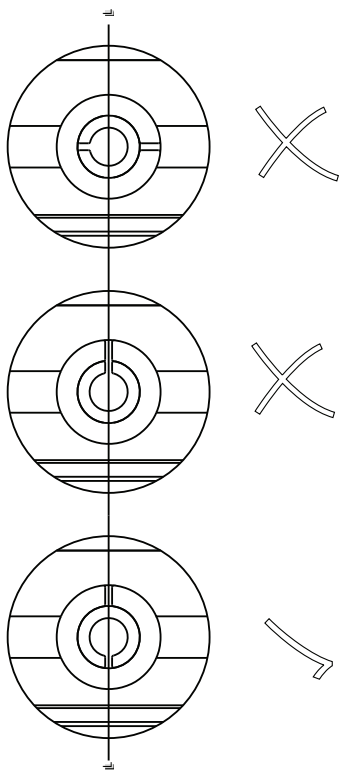

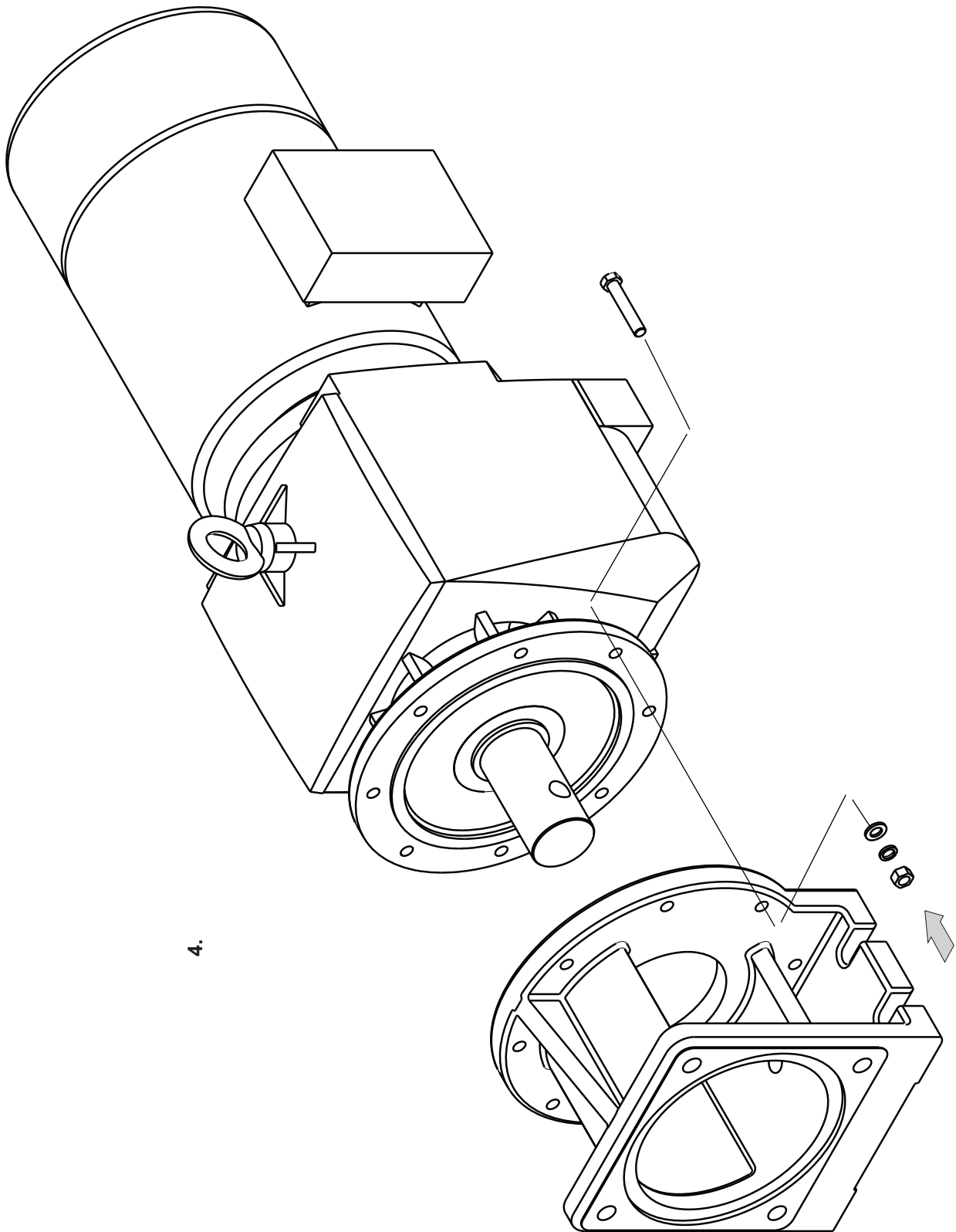

4.

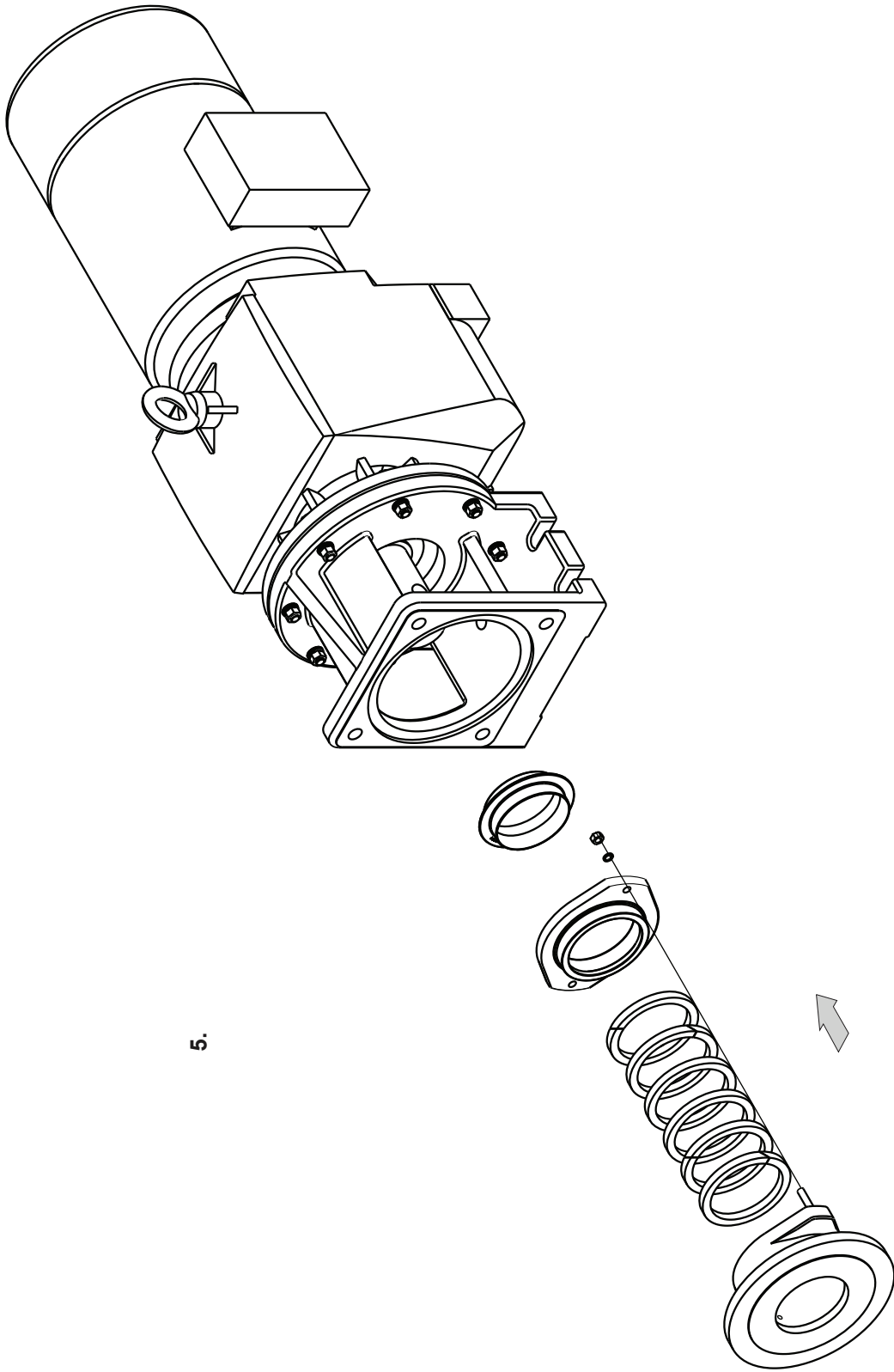

5.

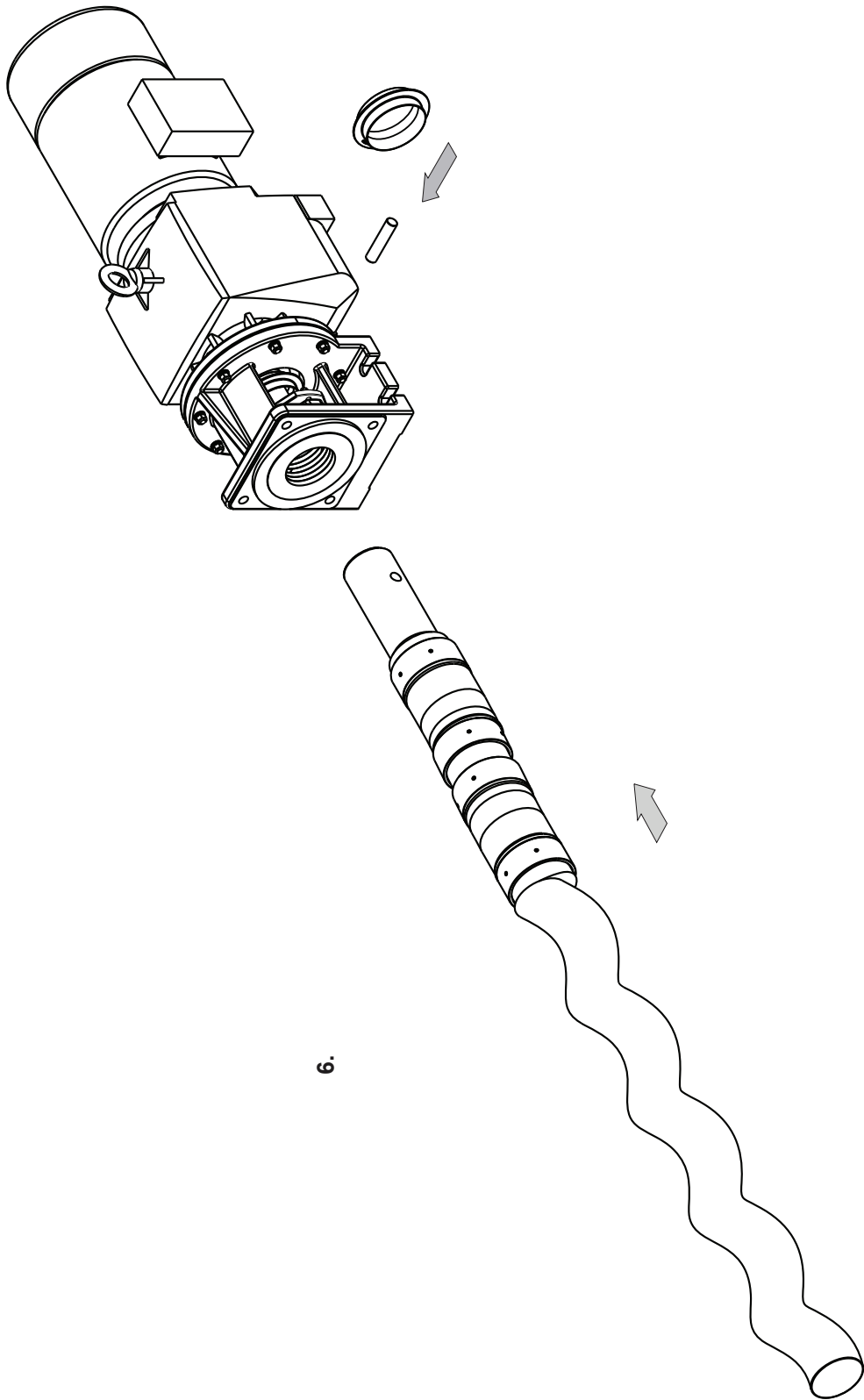

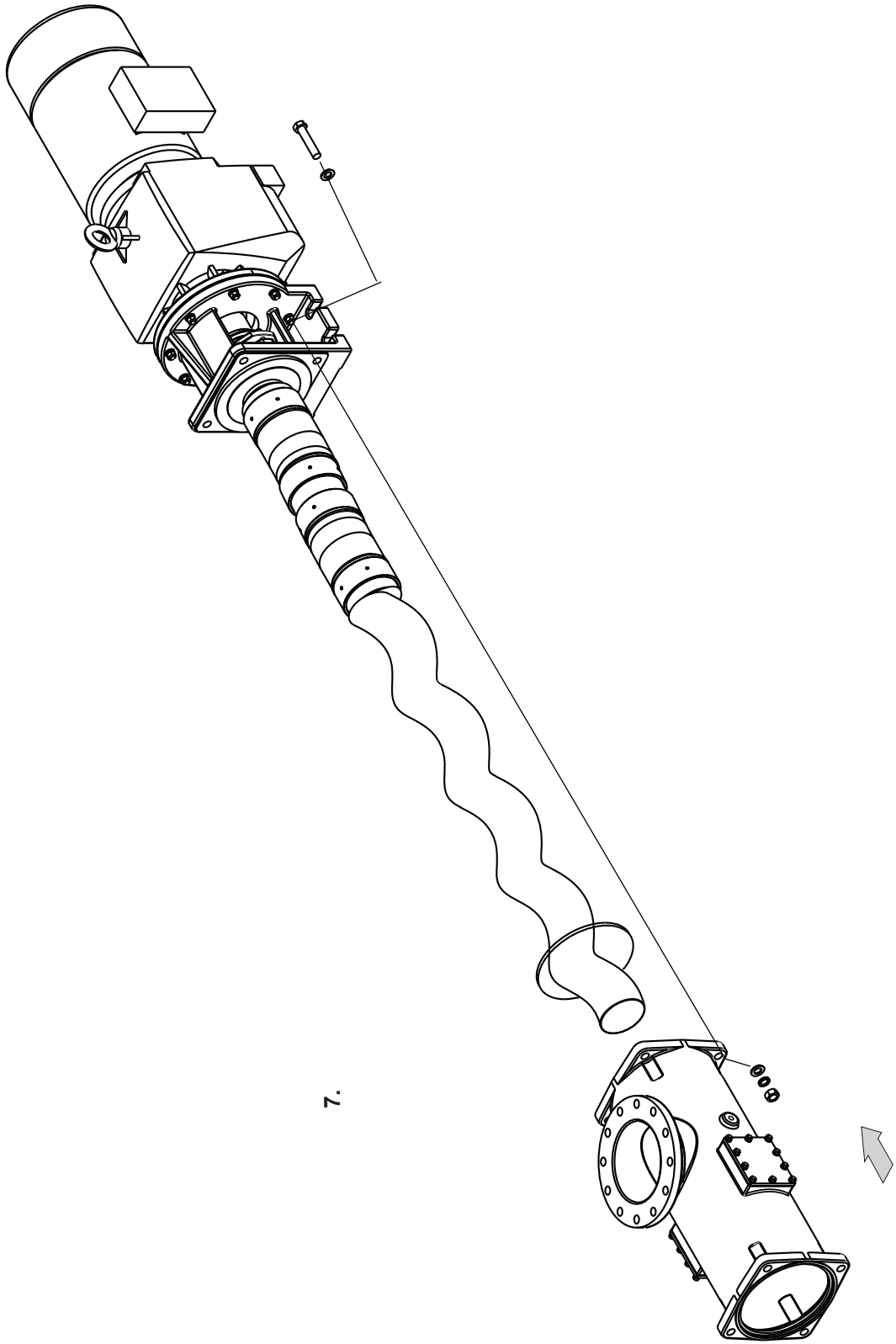

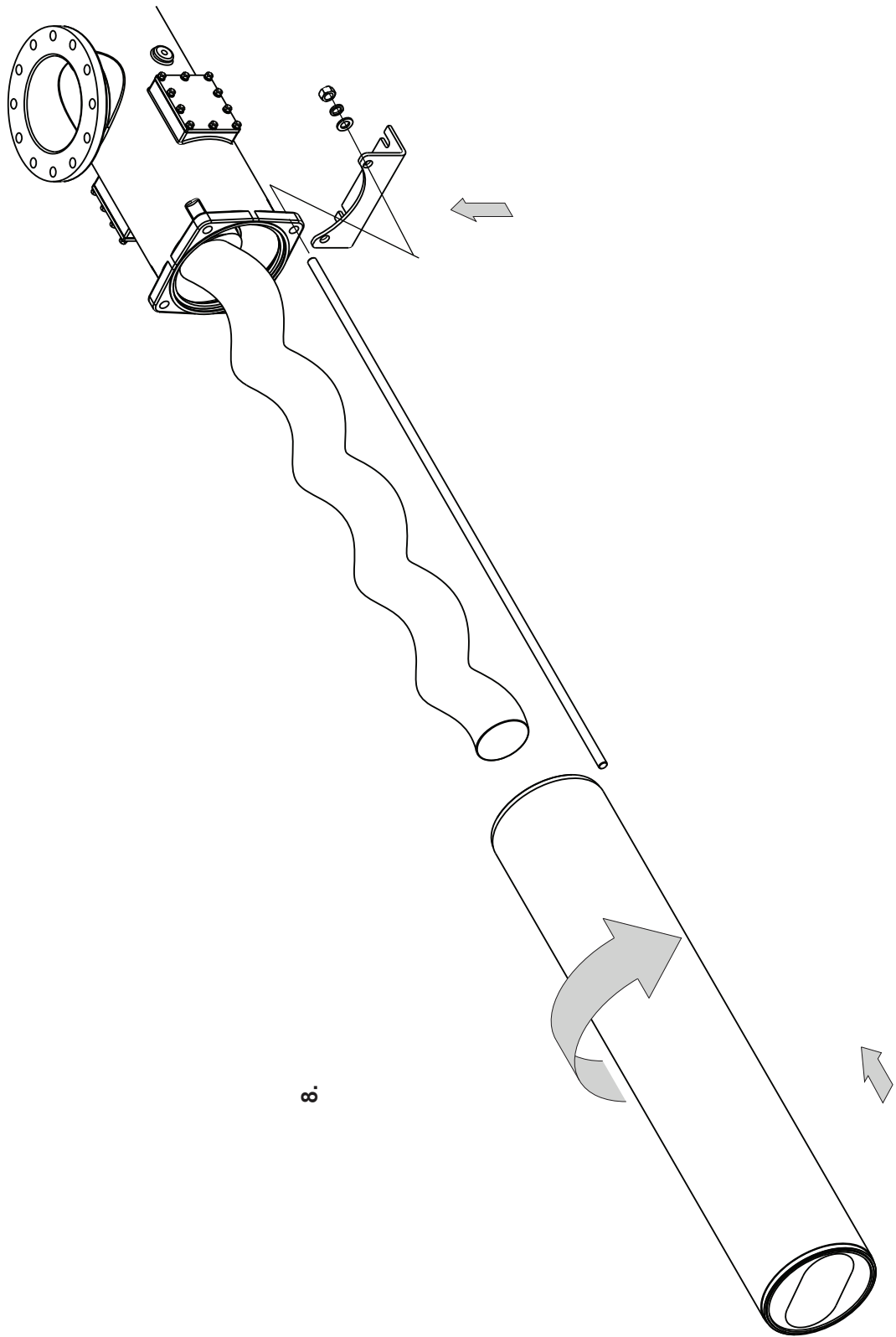

8.

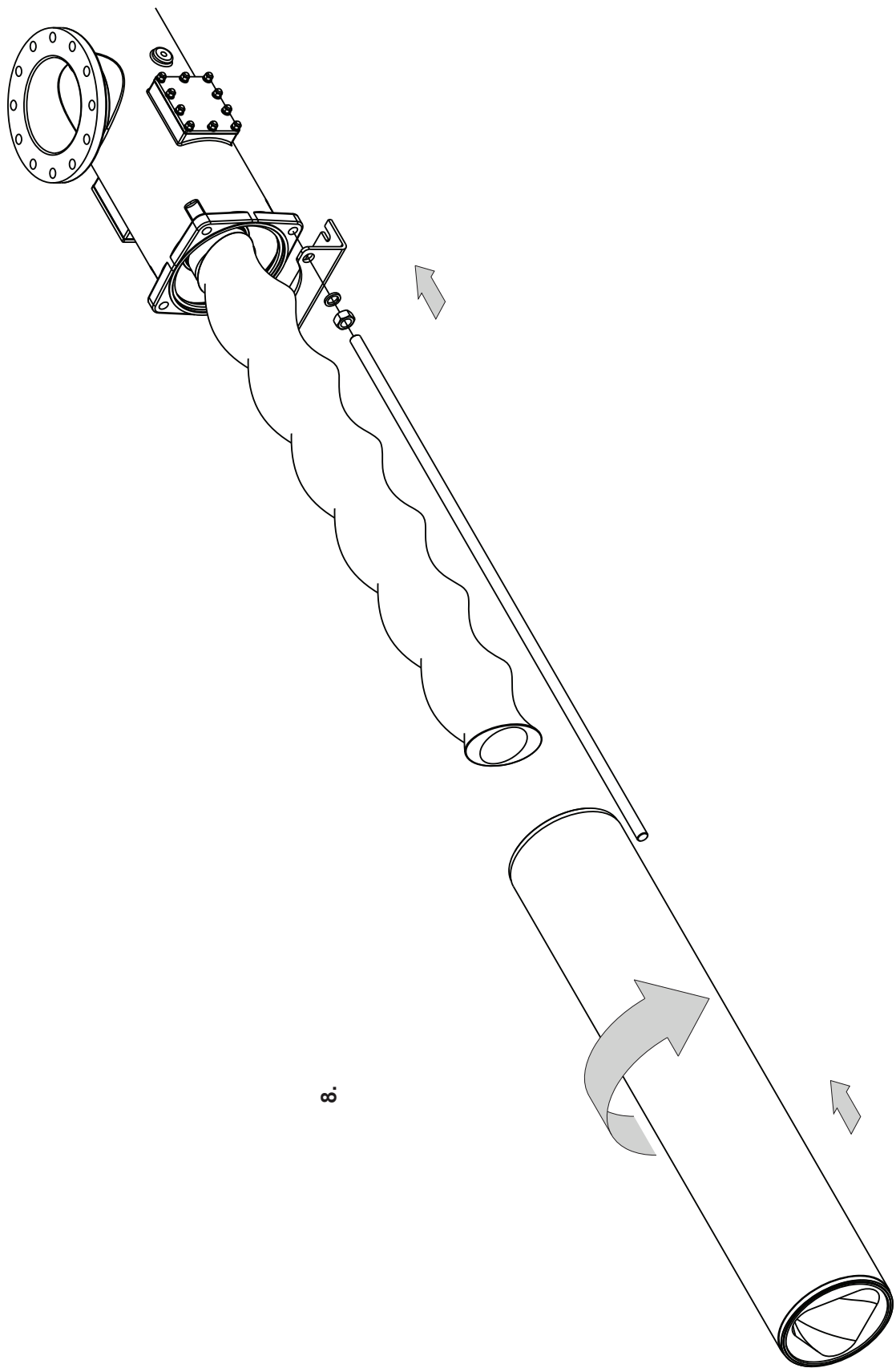

8.

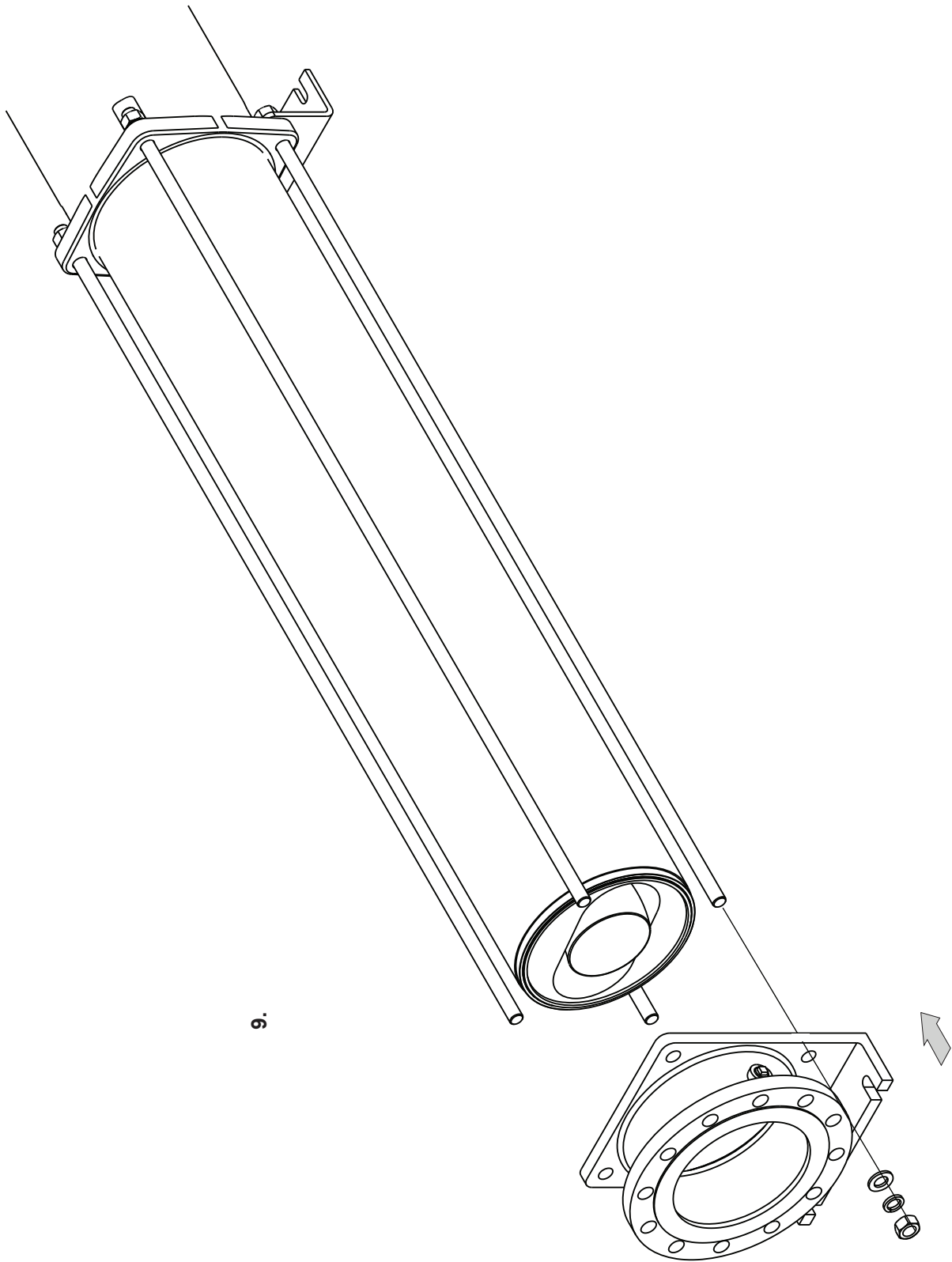

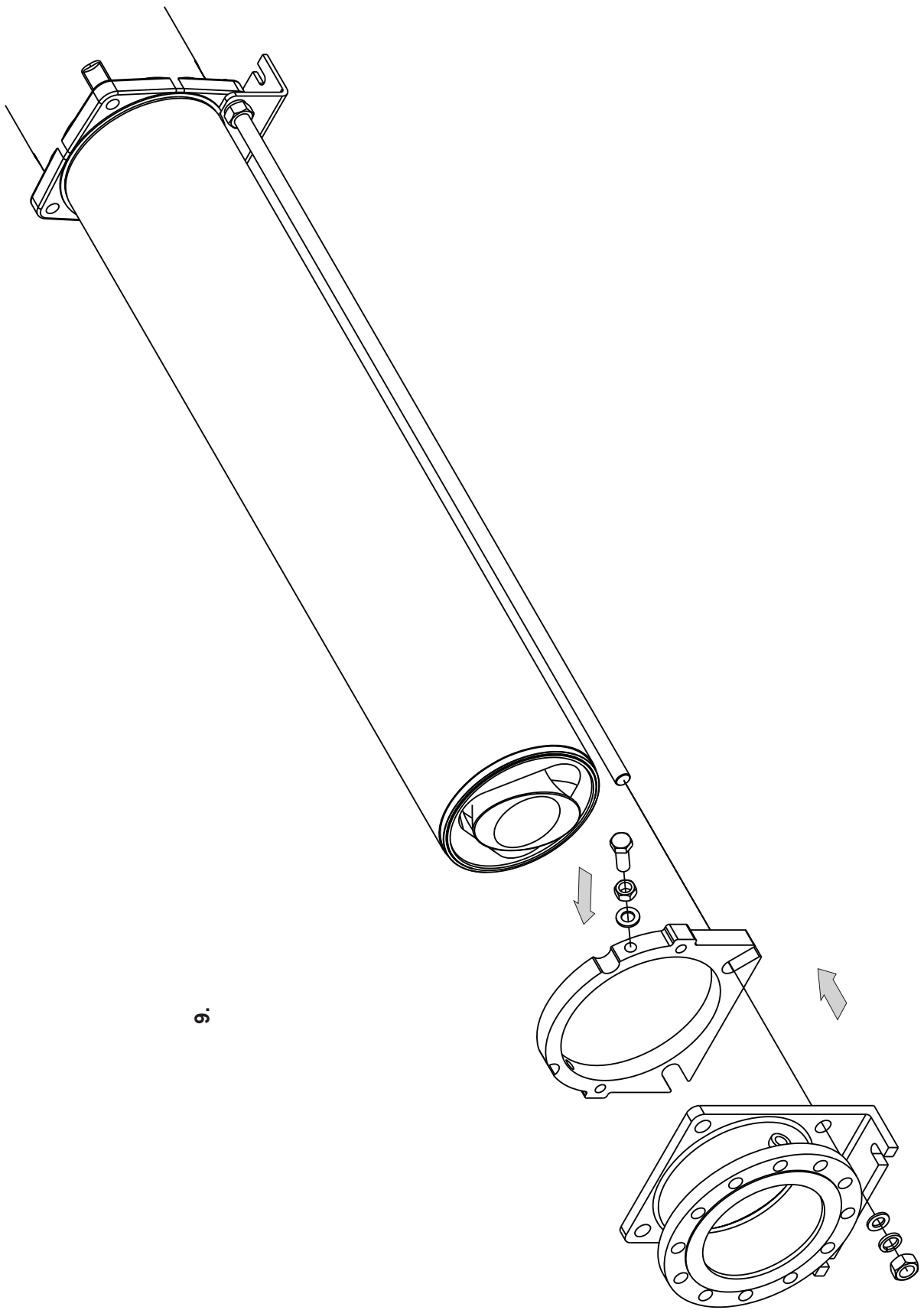

9.

BARESHAFTE MODELS ONLY

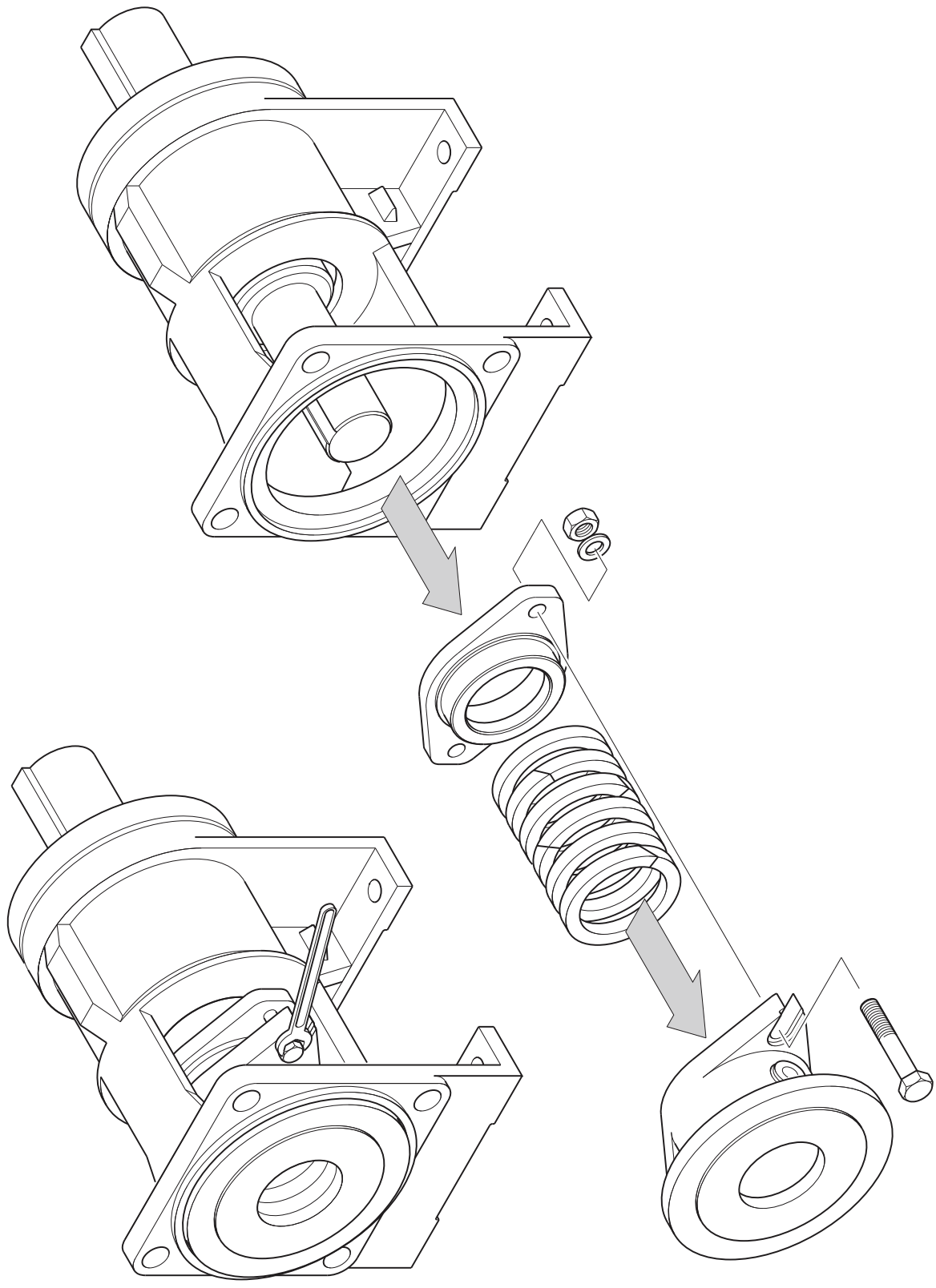

BARESHAFTE MODELS ONLY

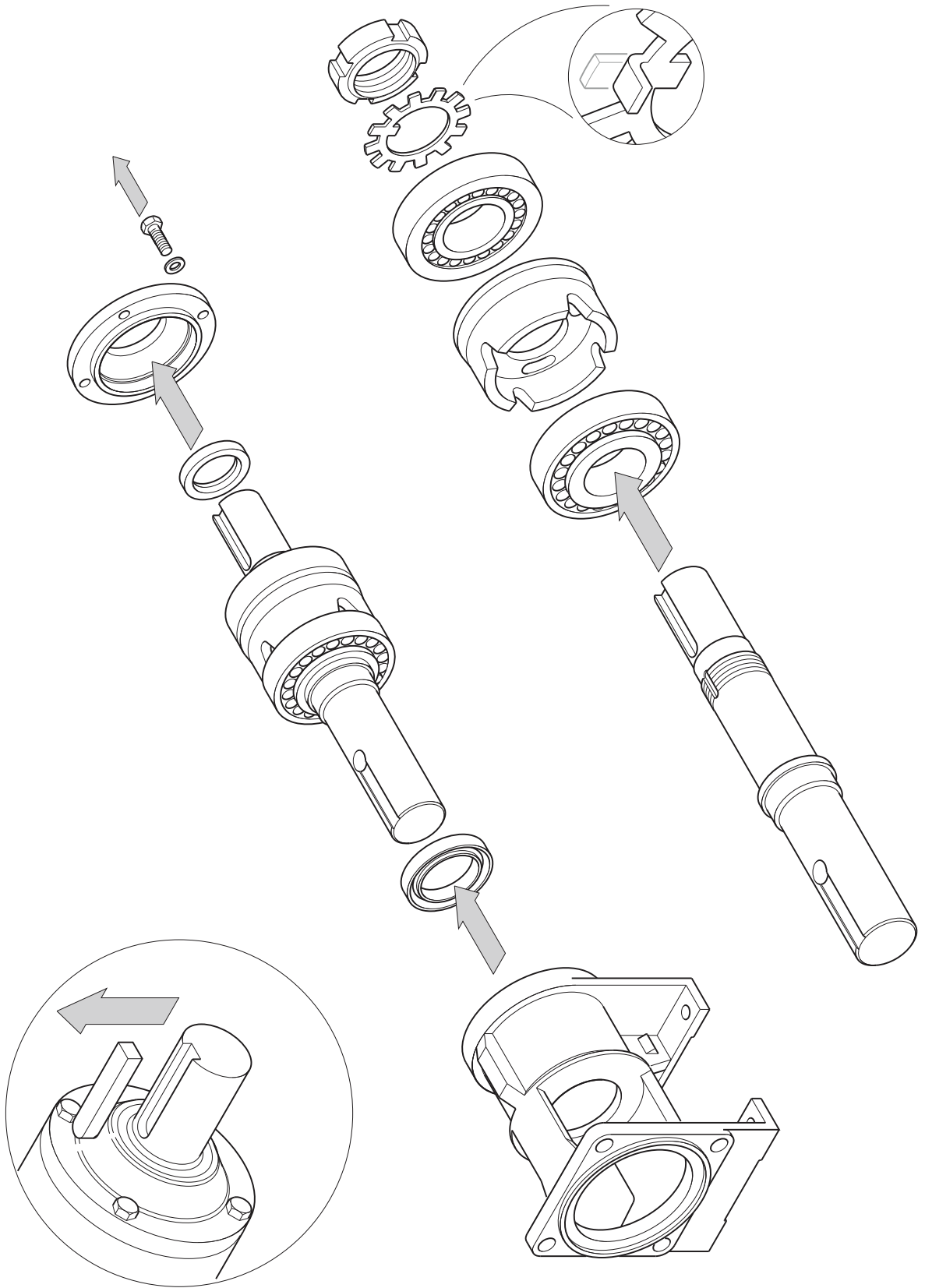

BARESHAFTE MODELS ONLY

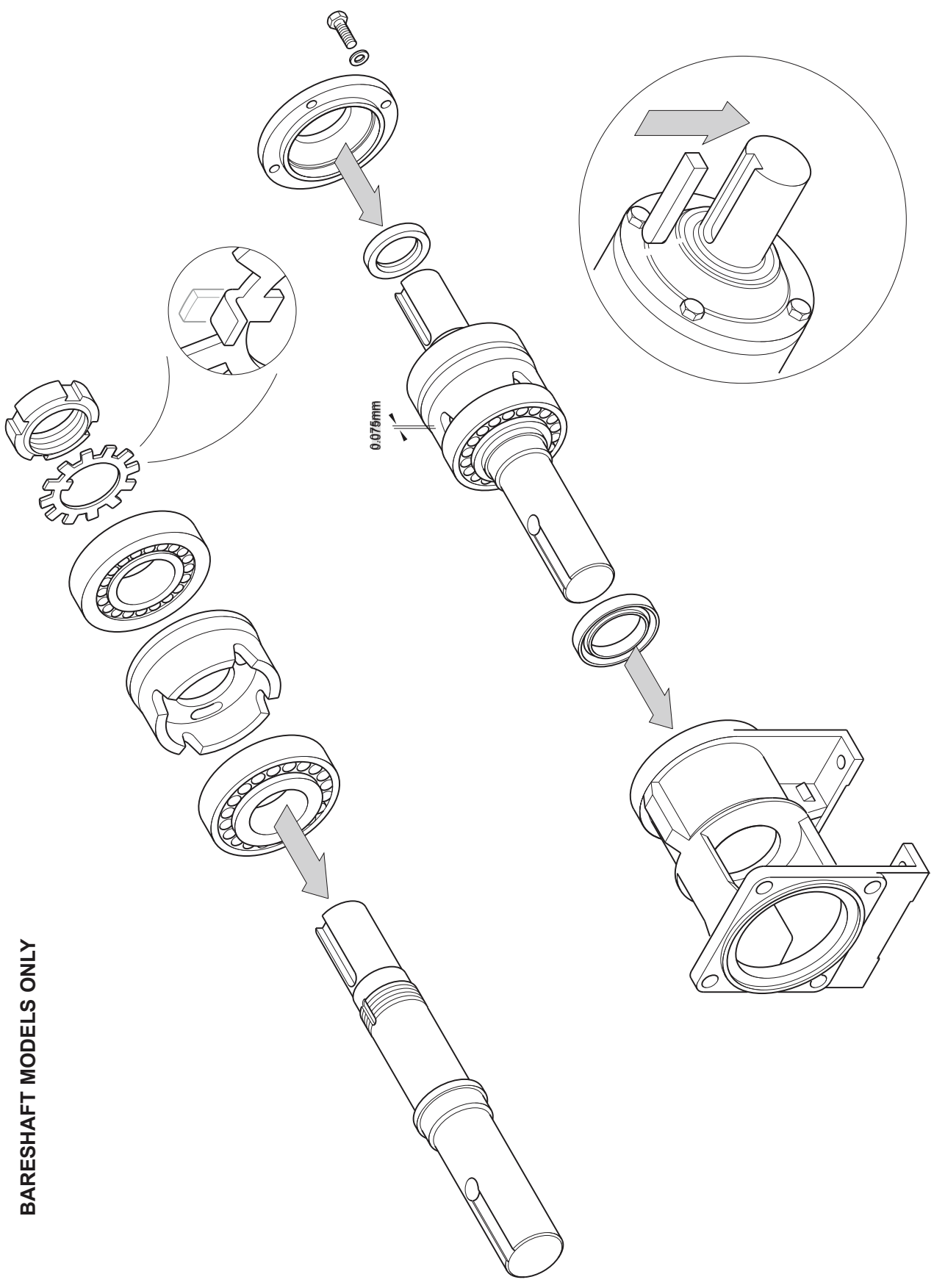

BARESHAFTE MODELS ONLY

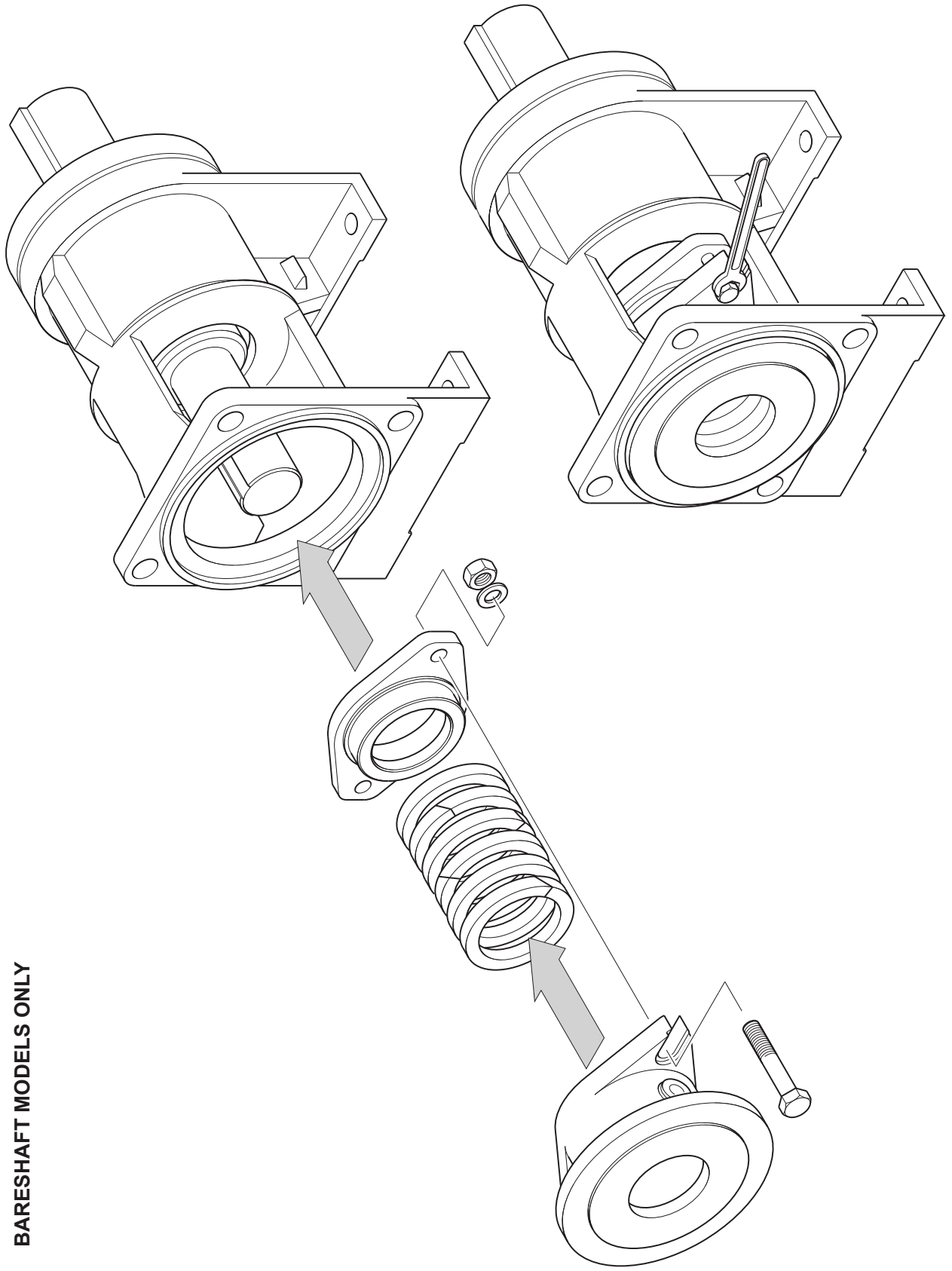

Exploded Views

COMPACT RANGE C1BB, C1CA & C1DA

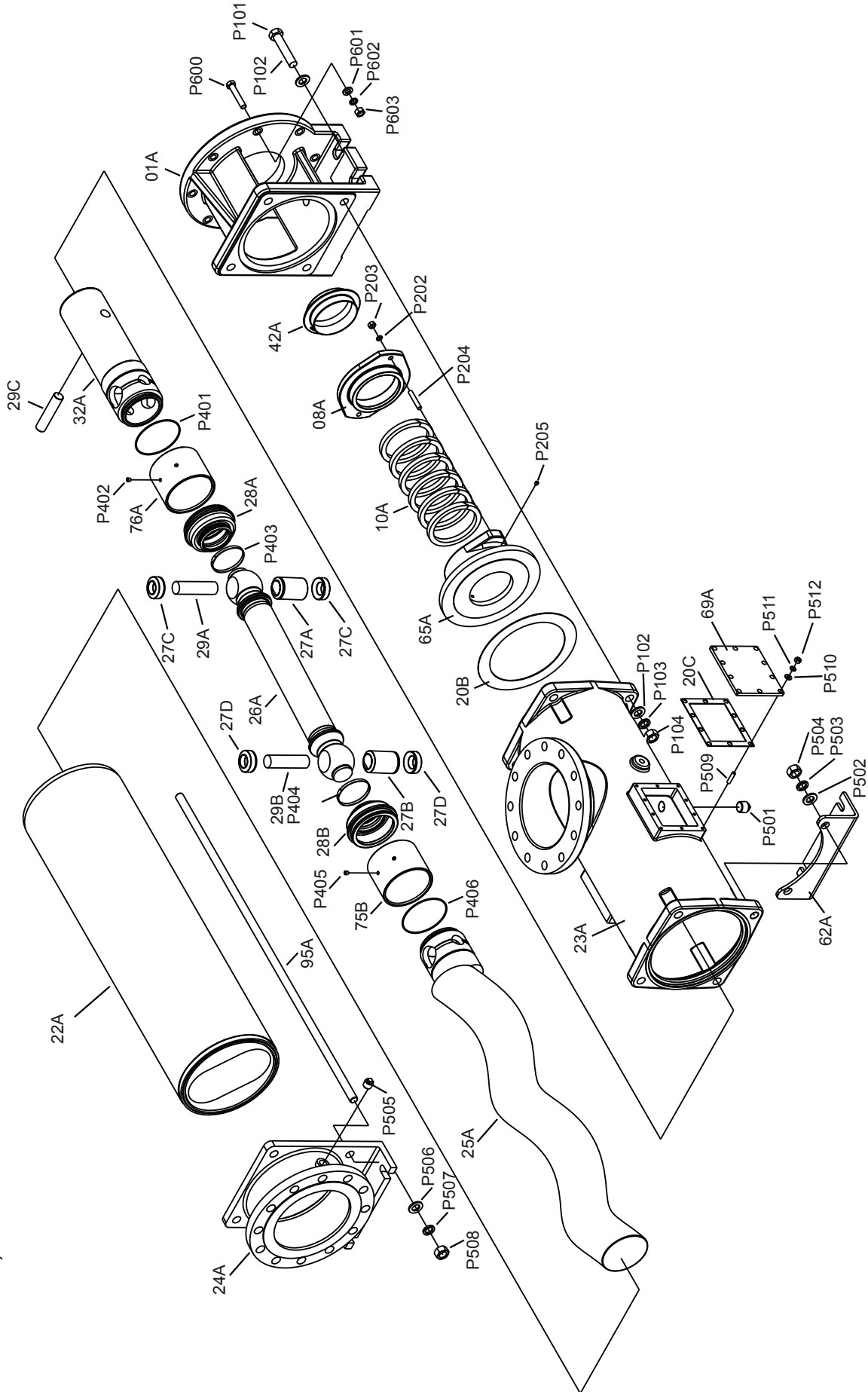

**BODY ADAPTER
FOR C1BB**

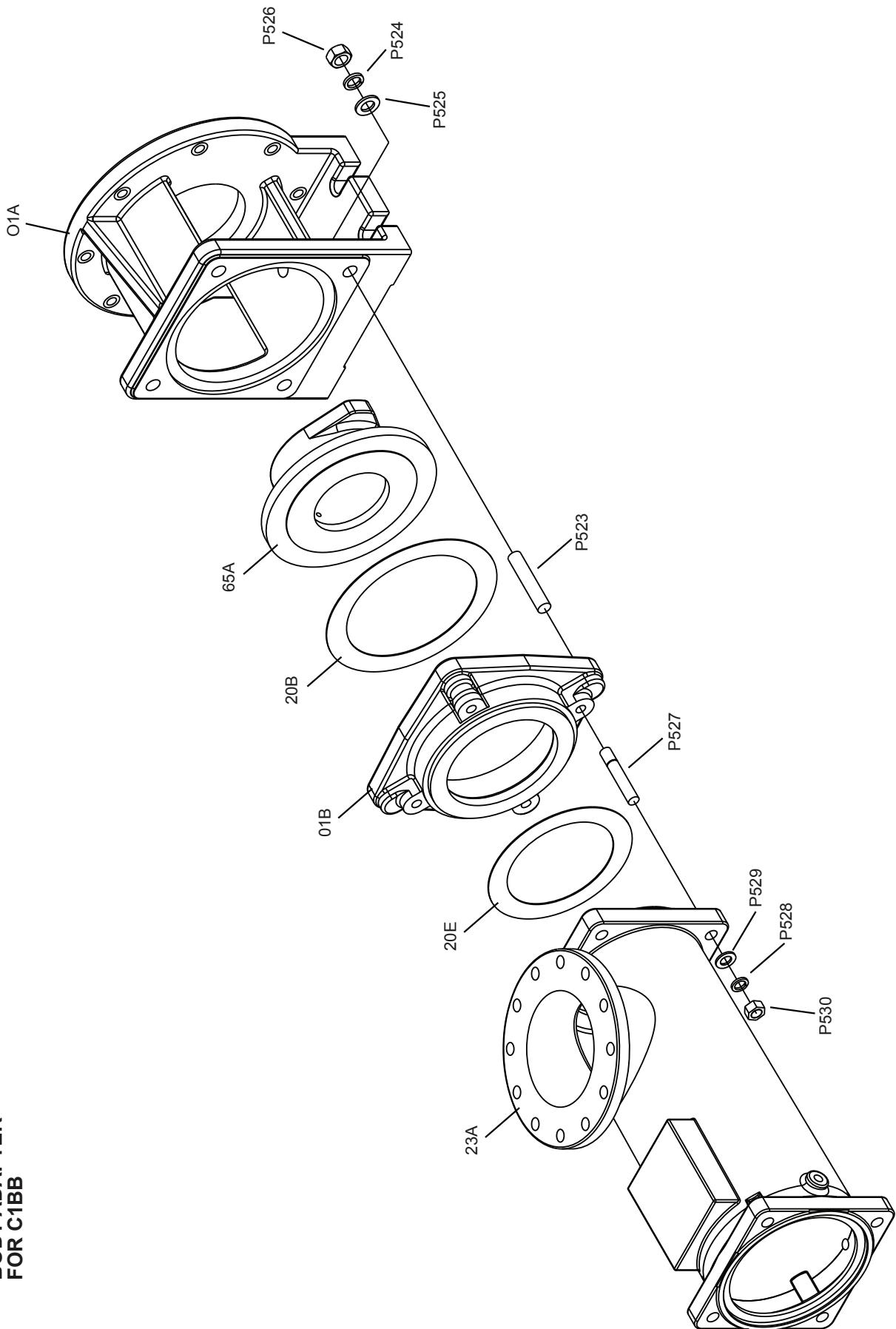

C1CK & C1CB

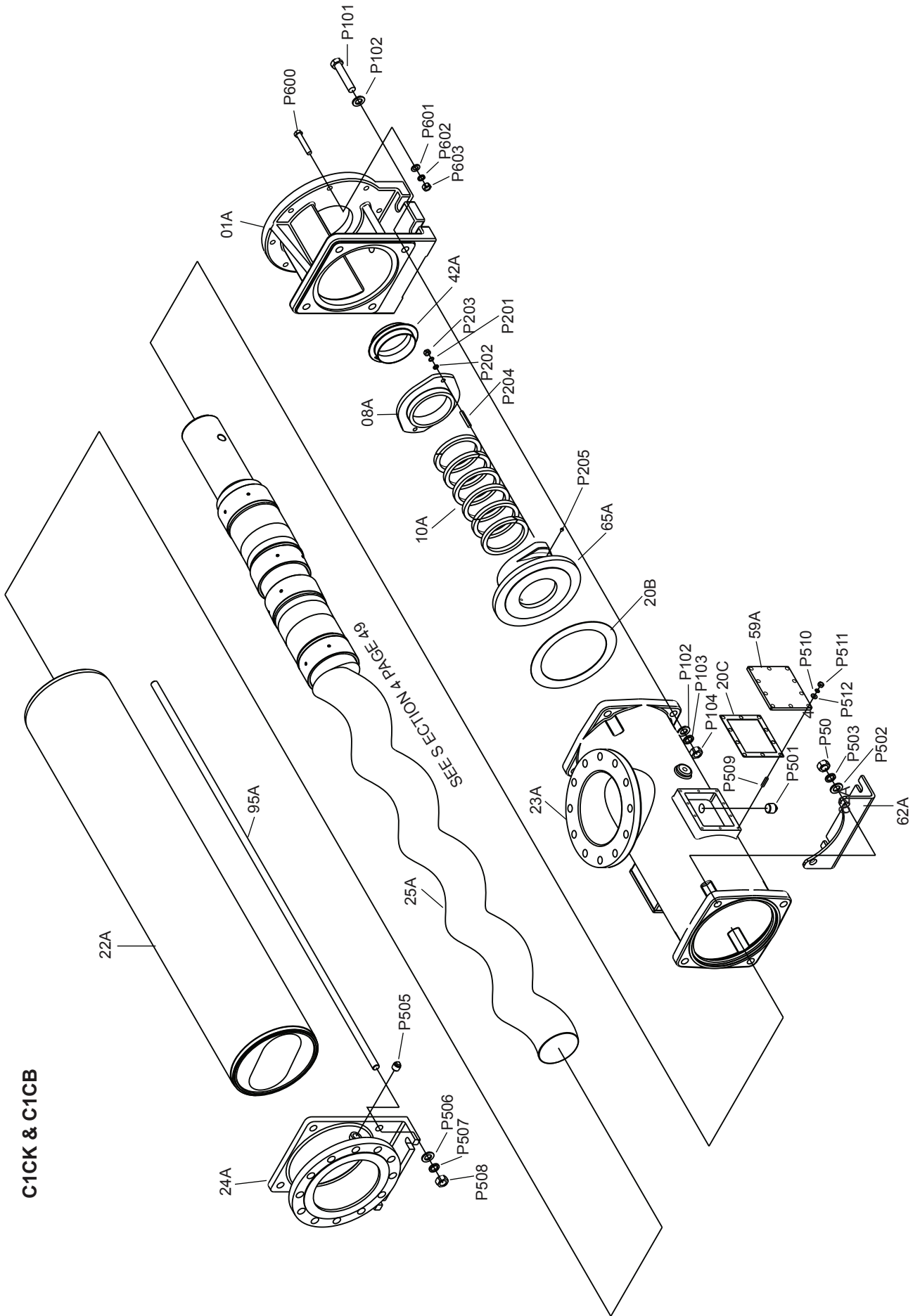

C1DB & C1EB

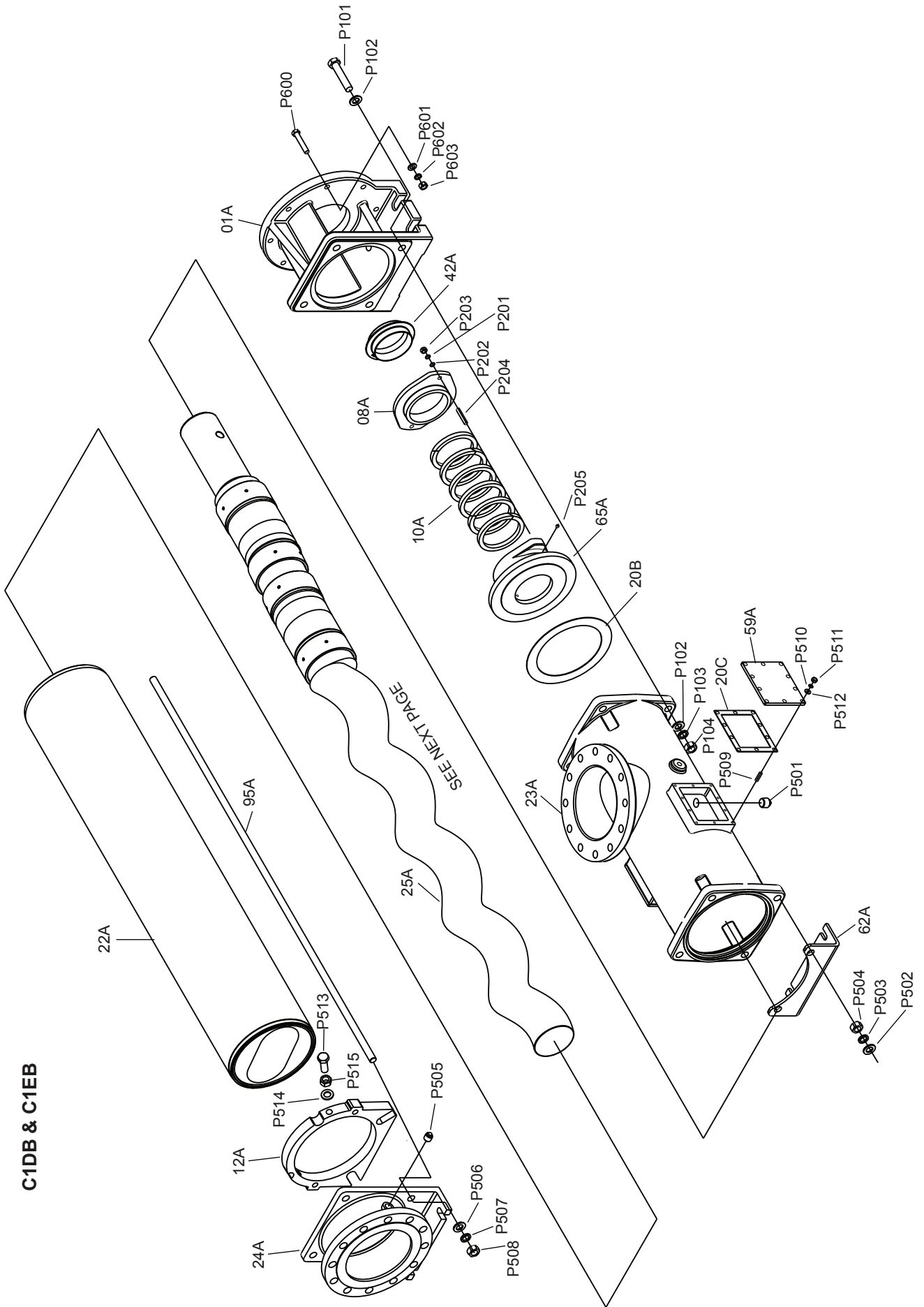

C1CK, C1CB, C1DB & C1EB
CONTINUED

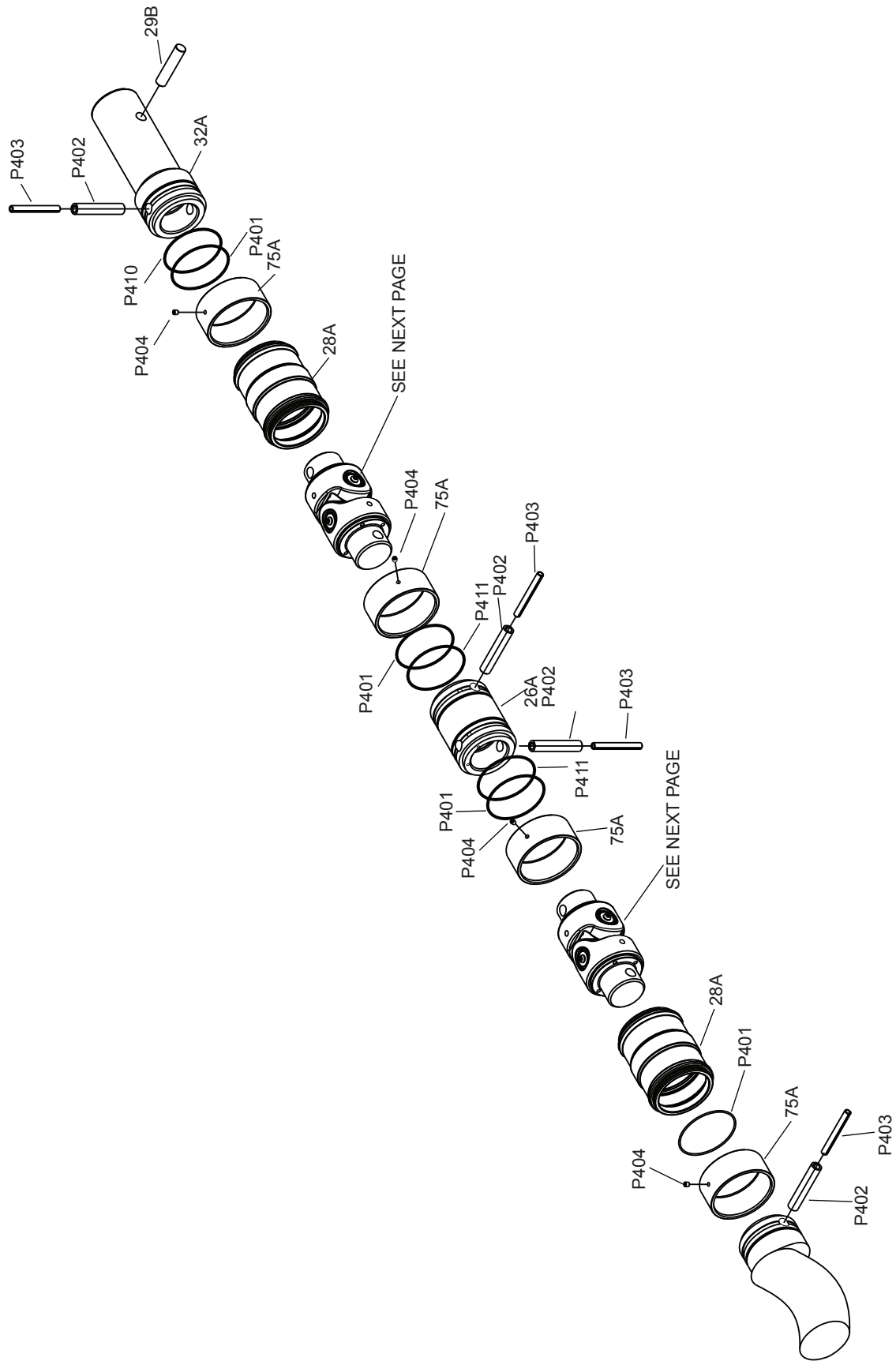

**C1CK, C1CB, C1DB & C1EB
CONTINUED**

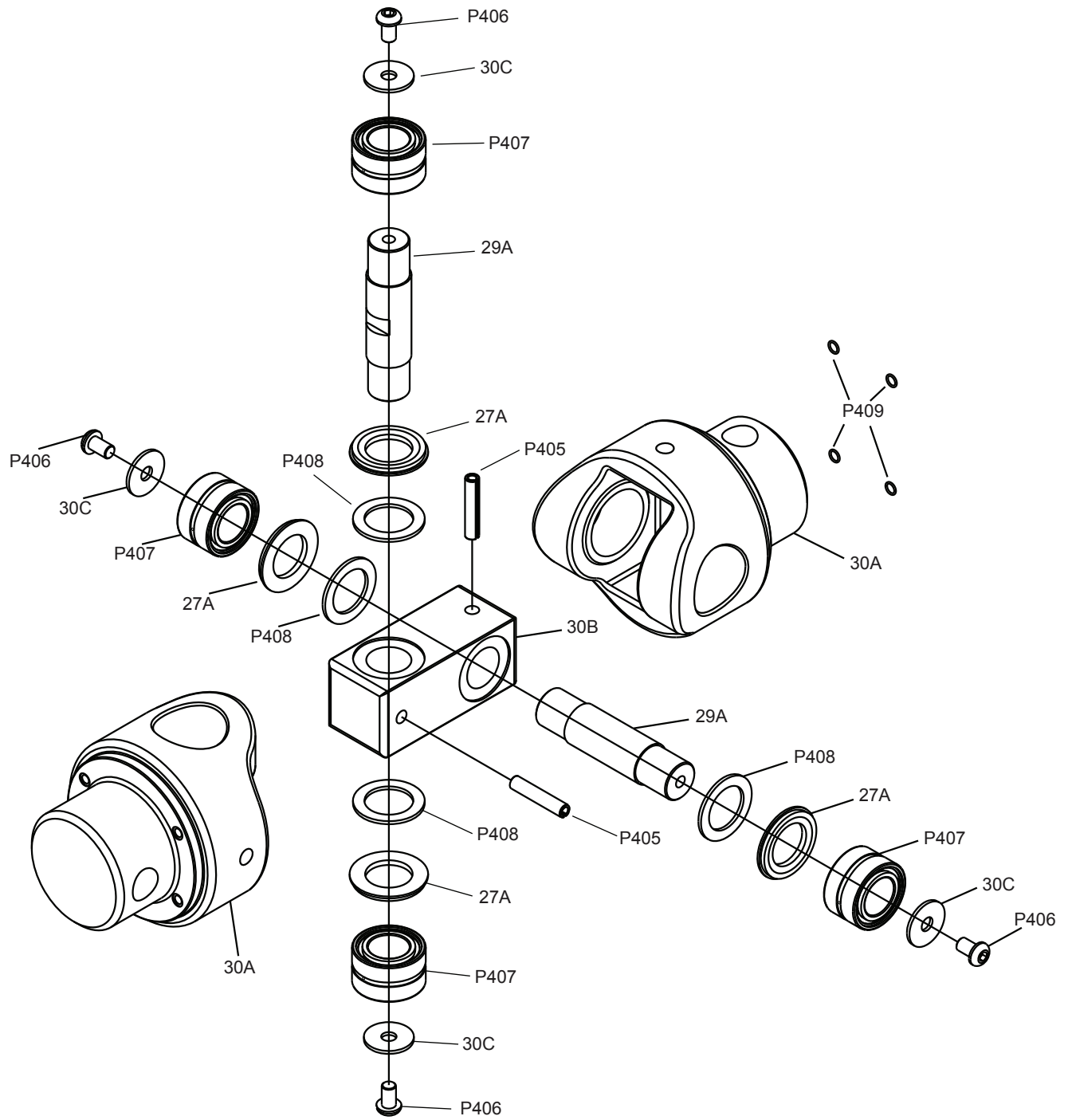

BARESHAFTE MODELS ONLY

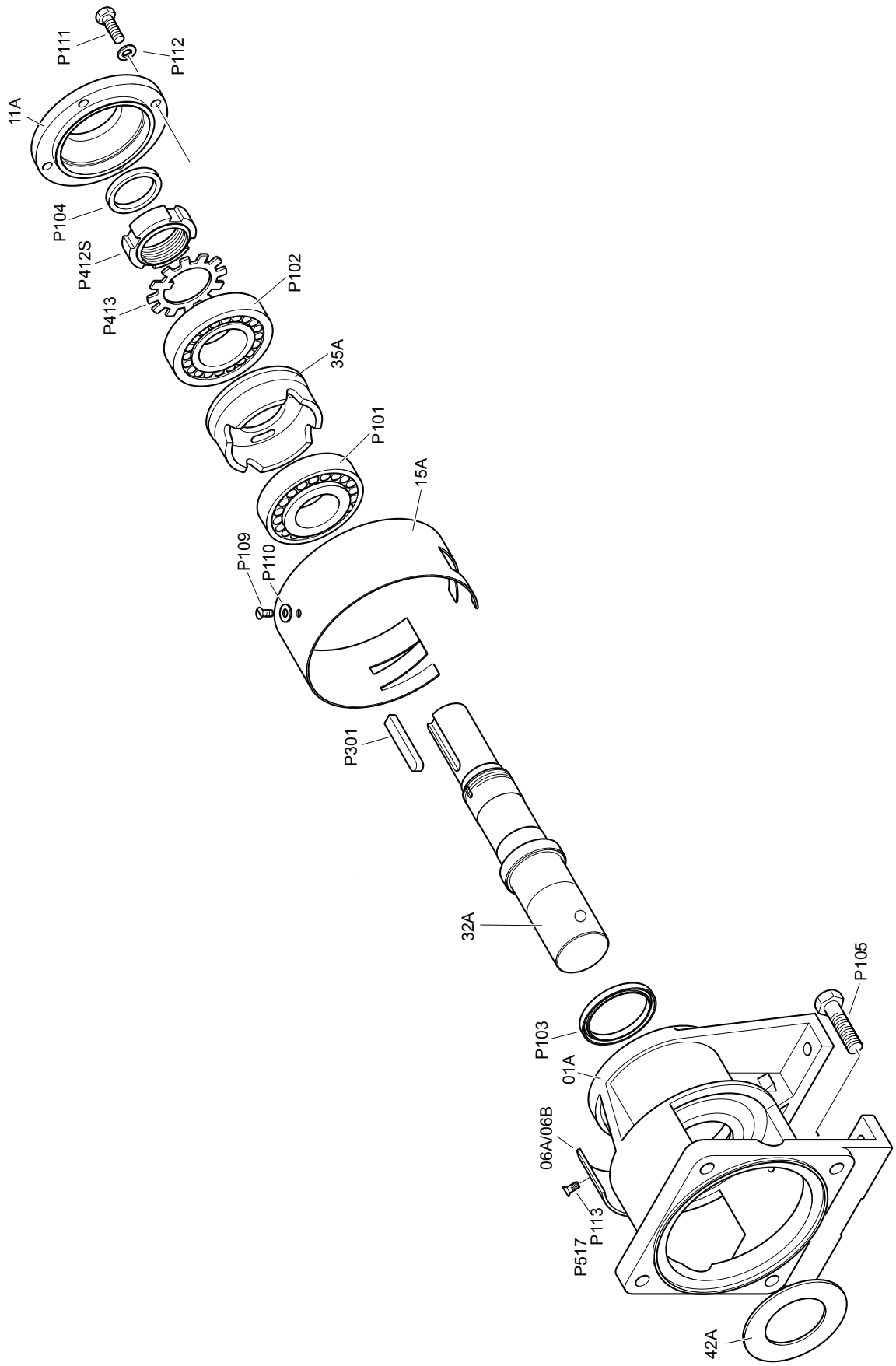

Drive Shaft Assembly with Plug

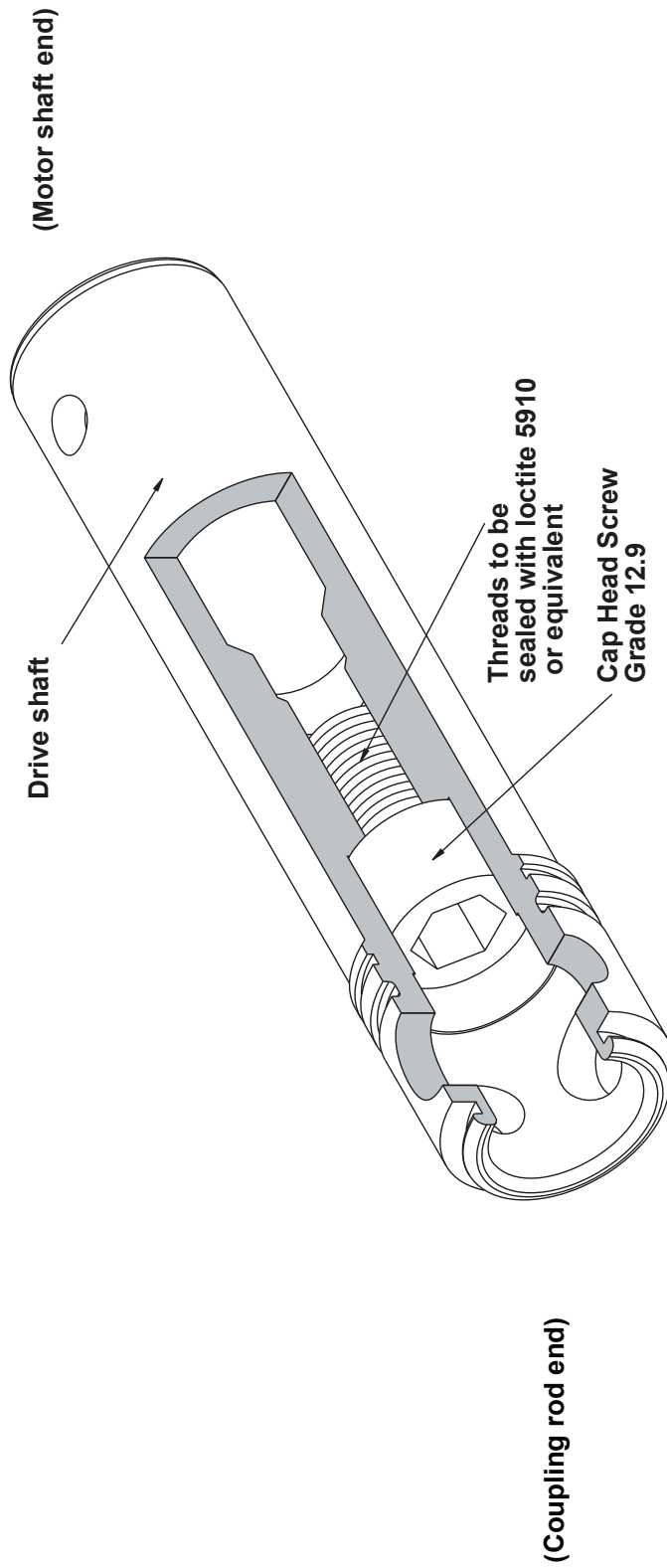

NOTE: ENSURE THE CAP HEAD SCREW IS TIGHTENED & SEALED BEFORE ASSEMBLING WITH COUPLING ROD

Torque Tightening Figures

Pump Size	Body/Suction Chamber (Nm)	Stator Tie Bars (Nm)	Bearing Cover (Nm)
	P526 P104 P530	P508, P504	P111
C1BB	190 -120	120	17
C1CA	190	190	17
C1CK	190	190	17
C1CB	190	190	17
C1DA	190	190	17
C1DB	190	450	17
C1EB	190	450	17

Note: Torque tolerances are +/-5% of stated nominal figures.

Pump Size	Body/Suction Chamber (lb/ftf)	Stator Tie Bars (lb/ftf)	Bearing Cover (lb/ftf)
	P526 P104 P530	P508, P504	P111
C1BB	140 - 88.5	88.5	12.5
C1CA	140	140	12.5
C1CK	140	140	12.5
C1CB	140	140	12.5
C1DA	140	140	12.5
C1DB	140	332	12.5
C1EB	140	332	12.5

Note: Torque tolerances are +/-5% of stated nominal figures.

Pin Joint Lubrication

Pump Model	Joint Lubrication Capacity (Approx) per Joint (ml)	Non-Food Applications Only		Food Applications
		Recommended	Suitable Alternative	
C1BB C1CA C1DA	620	GH6-460 Oil SHC 320	Mobil Gear Oil SHC 320	Kluberoil 4 UHI 460
C1CK C1CB C1DB C1EB	1200			

Pump Model	Joint Lubrication Capacity (Approx) per Joint (USgal)	Non-Food Applications Only		Food Applications
		Recommended	Suitable Alternative	
C1BB C1CA C1DA	0.16	GH6-460 Oil SHC 320	Mobil Gear Oil SHC 320	Kluberoil 4 UHI 460
C1CK C1CB C1DB C1EB	0.32			

Recommended Lubrication & Service Intervals

COMPONENTS	ALL APPLICATION EXCEPT FOOD	FOOD APPLICATIONS ONLY	SERVICE COMMENTS
PUMP DRIVE JOINTS	SEE TABLE ABOVE		INSPECT AND LUBRICATE AS NECESSARY EVERY 4000 OPERATING HOURS
PUMP BEARINGS (WHERE FITTED)	BP Energrease LC2 OR EQUIVALENT		INSPECT AND RE GREASE IF NECESSARY EVERY 12 MONTHS
GEARED DRIVERS (WHERE FITTED)	AS RECOMMENDED BY THE MANUFACTURER		
<p>NOTE: ABOVE SERVICE AND LUBRICATION INTERVALS ARE FOR GUIDANCE ONLY TO ENSURE MAXIMUM COMPONENT LIFE. PUMP WILL OPERATE FOR CONSIDERABLY LONGER PERIODS WITHOUT ATTENTION DEPENDING ON SERVICE CONDITIONS</p>			



nov.com/industrial

© National Oilwell Varco - All rights reserved