



English

Installation, Operation and Maintenance Instructions

Discam

Spares & Service Contact Details

Mono UK

Spares	+44 (0)161 214 2380 (direct line 8.15 am – 5.00 pm)
E-mail	spares@mono-pumps.com
Service	+44 (0)161 214 2390 (direct line 8.15 am – 5.00 pm)
E-mail	customerservices@mono-pumps.com
Service	+44 (0)161 339 9000 (24 hrs)

Mono Australia

	Telephone	Facsimile
Melbourne	(03) 9580 5211	(03) 9580 9036
Sydney	(02) 9521 5611	(02) 9542 3649
Brisbane	(07) 3350 4582	(07) 3350 3750
Adelaide	(08) 8447 8333	(08) 8447 8373
Perth	(08) 9479 0444	(08) 9479 0400
Darwin	(08) 8984 3099	(08) 8947 0540
Tasmania	(03) 6249 8704	(03) 6249 8756
E-mail	ozsales@mono-pumps.com	

Mono New Zealand

Spares & Service	+64 (0)9 829 0333
E-mail	info@mono-pumps.co.nz

Monoflo USA

Spares & Service	+1 713 466 7999
E-mail	inquire@monoflo.com

Monoflo South America

Spares & Service	+54 4296 8997	+54 4284 0323
E-mail	inquire@monoflo.com	

Mono China

	Telephone	Facsimile
Beijing	+86 (0) 10 6461 1115	+86 (0) 10 8486 8481
Shanghai	+86 (0) 21 5915 7168	+86 (0) 21 5915 6863
E-mail	info@mono-pumps.com	

Tools

For servicing and maintenance work on the Discam the following tools are recommended.

Metric Hexagon (Allen) Keys - Range 5mm - 14mm

Metric Spanners - Range 13mm - 45mm

Torque Wrench

Circlip Pliers

Lock Nut Key - MB D000 9750

All equipment should be in good working condition with no signs of excessive wear.

Introduction

Discam

This information and all the information contained herein, are the exclusive property of Monoflo, and contain information of a proprietary nature. It is provided for the sole purpose of transmitting the information contained to the designated recipient.

This information is to be used only as specified in the instrument of transmittal. It is not to be reproduced, copied in whole, or in part, nor is information it contains to be disclosed in any manner without the written consent of Monoflo. Its use for any other reason than the specified shall be a violation of the agreement with the recipient concerning the legal rights of Monoflo.

Monoflo reserves the right to make changes, which may obsolete certain parts of this manual.

The manual gives a guide to the operation and maintenance of the Discam given that all Health and Safety and good engineering practices are observed.

The information below is for contract No. _____
supplied.

_____ and gives the duty for which the equipment is

 One Company, Unlimited Solutions	
<hr/>	
<h2>The Discam[®]</h2>	
MODEL No.	<input type="text"/>
SERIAL No.	<input type="text"/>
DATE OF MANUFACTURE	<input type="text"/>
<p>Monoflo Inc., 9700 West Gulf Bank Houston, Texas 77040, USA T. +1 281 272 7700 E. inquire@monoflo.com</p>	

Index

SECTION 1	CODING SHEET
SECTION 2	INSTALLATION & OPERATION PROCEDURE
SECTION 3	DISMANTLING AND ASSEMBLY DIAGRAMS
SECTION 4	BUILD UP
SECTION 5	EXPLODED VIEWS & PARTS LIST
SECTION 6	LOCTITE ASSEMBLY
SECTION 7	LIFTING ARRANGEMENT

Installation, Operation & Maintenance Instructions

1.0 INSTALLATION

1.1 INSTALLATION & SAFETY RECOMMENDATIONS

In common with other items of process plant a Discam must be installed correctly to ensure satisfactory and safe operation. The Discam must also be maintained to a suitable standard. Following these recommendations will ensure that the safety of personnel and satisfactory operation of the Discam is achieved.

1.1.1 OPERATING PRINCIPLE

INTRODUCTION

The Discam is a combined screen and grinder. Screened solids are passed directly from the screening element in to the grinding unit giving improved solids handling and minimising the risk of solids hanging up between the two elements. The external side frames incorporate guide rails to aid installation and removal for maintenance. The two elements of the machine are fitted with separate drives which enables them to be matched to the requirements of their two separate functions and minimise the overall power consumption of the unit.

SCREENING ELEMENT

The screening element is based on the Mono L Series Discreen. The screen is of a modular design so additional shaft stacks can be added where higher capacities are required. Each shaft rotates in the same direction as its neighbour so that solids are transferred across the face of the machine from one shaft to the next. The first and last disc stacks use thicker discs to maintain the screening gap and ensure an effective transfer of solids entering and leaving the screen.

GRINDING ELEMENT

The grinding element is based on Mono's Series A Muncher, having counter rotating shafts which draw solids in to the cutters. The availability of different cutter sizes and stacking arrangements enable different maceration sizes to be achieved as required by the downstream process. Guidance on this is given in the selection section of this manual.

Figure 1 shows how solids are transported across the face of the screen directly into the cutters.

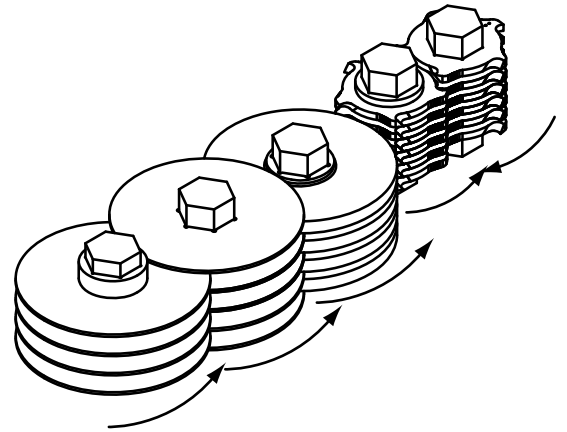

The Discam is available in throat depths of 1m, 1.5m and 2m with between 3 and 10 screen shafts as standard giving a wide range of capacities to suit different applications.

1.2 GENERAL

When handling harmful or objectionable materials, adequate ventilation must be provided in order to disperse dangerous concentrations of vapours. It is recommended that wherever possible, the Monoflo Discam should be installed with provision for adequate lighting, thus ensuring that effective maintenance can be carried out in satisfactory conditions. With certain product materials, a hosing down facility with adequate draining will simplify maintenance and prolong the life of the Discam components.

1.3 SYSTEM DESIGN AND INSTALLATION

MACHINE CONFIGURATION

The Discam should be configured to suit the installation and application. Refer to figure 2 and the coding sheet for details.

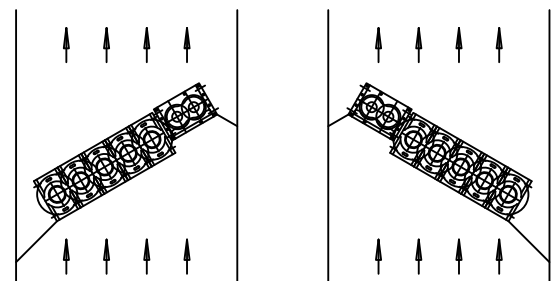

Fig 2a
Left Hand Discam

Fig 2b
Right Hand Discam

Installation, Operation & Maintenance Instructions

Where the Discam is installed in an inlet channel it should be at a minimum of 30° to the flow as shown in figure 2. Baffle plates should be fitted either side of the Discam to guide solids across the screen and into the grinder

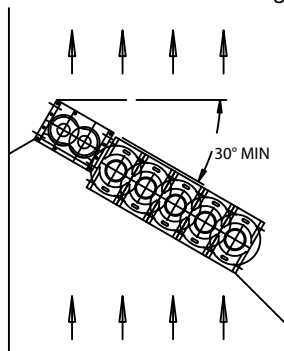

Fig 2 Minimum Installation Angle 30°

CHANNEL DESIGN RECOMMENDATIONS

The design of the channel should be such that it promotes flow across the face of the screen and prevents the build up of solids in 'dead areas'. A dry weather channel is recommended to maintain fluid velocities and reduce deposition of solids at times of low flow. This should direct the flow towards the grinder as shown in figure 3.

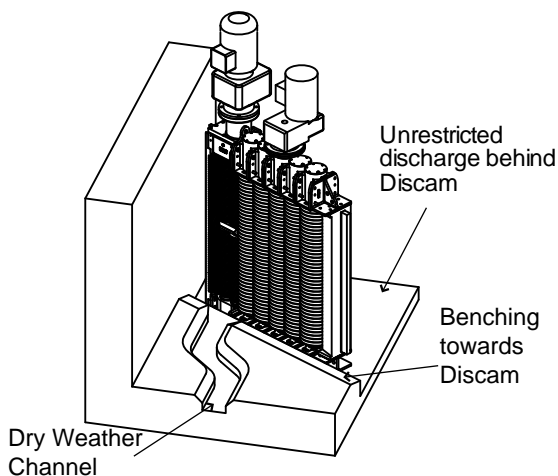

Fig 3 Channel Design Recommendations

DESIGN OF SUPPORTING FRAMEWORK

The support framework should be designed such that it promotes a clear passage of solids across the face of the screening element and into the grinder element. There should be no areas which allow solids to collect as they will quickly build up and reduce the efficiency of the Discam.

The support framework should have sufficient mechanical strength to resist all mechanical and hydraulic loads it is likely to be subjected to. Where impact from large objects such as tree branches is likely we recommend that deflector bars are fitted in front of the machine to prevent damage to the discs or shafts.

The cast in guides on each end of the Discam simplify the design of the framework and make installation and removal quick and easy. Baffle plates should be added to the installation to guide the flow into the Discam and prevent the build up of solids around the support frame. A typical support frame arrangement is shown in figure 4.

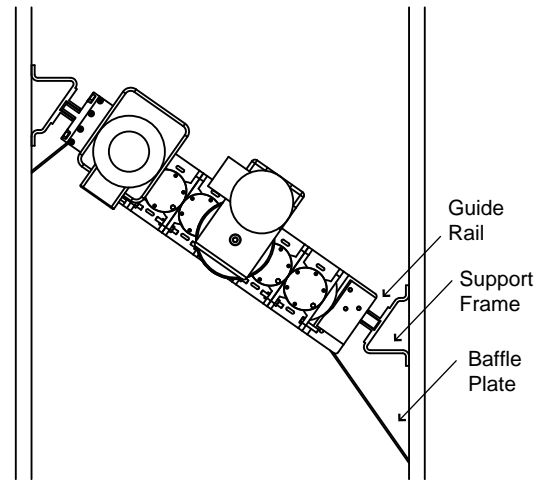

Fig 4 Support Frame

Monoflo is able to supply custom made support framework/ top and bottom baffle plates which are specifically designed to suit the equipment and the installation requirements. Where support framework/ top and bottom baffle plates not approved by us are used we can not be held responsible if performance of the Discam is affected by their design or method of installation.

GUIDE RAIL SYSTEMS

Where the Discam is installed in an area where access is difficult, it is recommended that a guide rail system be used to aid removal for inspection and maintenance. Please contact Monoflo for further information on guide rail systems.

PROGRAMMABLE LOGIC CONTROLLER (PLC)

All Discams **must** be installed with a special PLC in the control circuit to protect the machine from overload and to ensure effective operation. **Failure to comply with this requirement could result in premature failure of the Discam and will invalidate the warranty.**

The control philosophy of the PLC is as follows:

When the absorbed power of the drive on either the grinder or screen has exceeded any of the pre-programmed set points the unit will stop for approximately 1 second to allow the mechanics to come fully to rest. The unit will then automatically reverse the Muncher and Discreen for 2 seconds to clear any debris, after a further 1 second delay the unit will attempt to restart in forward. If the unit tries to restart 3 times within a minute, but cannot clear the blockage, it will stop and produce an alarm indication on the panel door.

Installation, Operation & Maintenance Instructions

SUMMARY OF INSTALLATION REQUIREMENTS

- Install Discam at a minimum angle of 30° to the flow.
- Bench the channel towards the Discam.
- Ensure unrestricted discharge behind the Discam.
- Use a dry weather channel directed towards the infeed of the grinder.
- Support frames must be strong enough to handle mechanical and hydraulic loads imposed. Use deflector bars where large objects could damage the machine.
- Use baffles to assist flow and eliminate build up of solids.
- Ensure there are no protrusion from supporting framework which might snag solids
- A PLC must be fitted to all Discams to prevent overloading.
- Use an IP68 drive where over-topping is a possibility.

1.4 HANDLING



During installation and maintenance, attention must be paid to the safe handling of all items. Where a Discam or its components weigh in excess of 20kg (45lb) it is recommended that suitable lifting tackle should be used to ensure that personal injury or damage to components does not occur.

A weight table is included at the end of this section.

Lifting illustrations are contained in this document - Section 7 Page 1.



NOTE
DO NOT ATTEMPT TO LIFT MUNCHER USING ONLY ONE LIFTING LUG. EXTREME CAUTION SHOULD BE OBSERVED FOR PERSONNEL SAFETY WHEN LIFTING HEAVY OBJECTS.

1.5 STORAGE

Discams are despatched from our factory with the cutter chamber sprayed with a moisture repellent coating and ready for immediate installation and operation.

Should the machine be stored or left stationary for any length of time it is recommended that the cutter bank is re-sprayed with anti-rust lubricant and that the shafts are rotated monthly.

Removing the motor cowl and turning the fan by hand is the easiest way to rotate the shafts.

Failure to do this may result in a higher frequency of reversals and in extreme cases the machine to seize due to the tight running clearances of the individual cutting elements during commissioning and initial start-up.

The starter panel if supplied should be stored in a controlled dry environment to prevent moisture build-up causing corrosion of contactors and other metallic components.

See manufacturer instructions for motor/gearbox/drive and panel storage procedures.

NOTE:

The Discam must be protected by a PLC control unit set up to the correct operating philosophy. Only PLC's supplied or approved by Monoflo should be used. Failure to observe this requirement may cause premature machine failure and could invalidate the warranty of the machine. It is also important that the PLC be correctly wired into the panel.

Please refer to Wiring Diagram – Section 2, Page 8.



IMMEDIATELY PRIOR TO INSTALLATION AND STARTING

Before installing the Discam please ensure that all plugs and inspection plates are replaced.



1.6 ELECTRICAL

Electrical connection should only be made using equipment suitable for both rating and environment. Where any doubts exist regarding the suitability of equipment. Monoflo should be consulted before proceeding.

Earthing points will be provided on electric drives (if supplied) and it is essential that these are correctly connected. The electrical installation should include appropriate isolating equipment to ensure that the unit is safe to work on.



Installation, Operation & Maintenance Instructions

1.7 GENERAL SAFETY



GREAT CARE MUST BE TAKEN TO PROTECT ALL ELECTRICAL EQUIPMENT FROM SPLASHING WHEN HOSING DOWN. WHERE MONOFLO HAVE SUPPLIED A BASIC DISCAM THE ONUS IS ON THE USER TO FIT ADEQUATE GUARDS IN COMPLIANCE WITH THE REQUIREMENTS OF THE RELEVANT REGULATIONS.



All nuts and bolts, securing flanges and base mounting fixtures must be checked for tightness before operation.

If, when starting, the Discam does not appear to operate correctly, the plant must be shut down immediately and the cause of the malfunction established before operations are recommenced.

NOTE:

NEVER inspect or work on or near the cutter chamber without first isolating and locking the machine.



GUARDS

In the interests of safety, and in accordance with relevant legislation, all guards must be replaced after necessary adjustments have been made.



1.7.1 WARNING /CONTROL DEVICE

Prior to operating the Discam, if any warning or control devices are fitted these must be set in accordance with their specific instructions.

1.7.2 NOISE LEVELS

The noise sound pressure level will not exceed 70dB at one metre distance from the Discam. This is based on a typical installation and does not necessarily include noise from other sources or any contribution from building reverberation.

1.8 EXPLOSIVE PRODUCTS/ HAZARDOUS ATMOSPHERES



In certain instances the product being treated may well be of a hazardous nature.

In these installations consideration must be given to provide suitable protection and appropriate warnings to safeguard personnel and plant.

1.9 LUBRICATION

The gearmotor(s) is supplied with the correct type and quantity of lubricant in the gearbox but should be checked before use. For further data see separate information supplied by manufacturer.

GRINDER ELEMENT

The drive gear chamber should be approximately two thirds full. Should replenishment be necessary use BP Energrease LC2.

SCREEN ELEMENT

The drive train of the screen element is fitted with an oil level sensor and sight glass. Should replenishment be necessary use Kluber SynthosoD460 EP oil.

LIPSEALS

All lipseals should be liberally lubricated with General Purpose grease or equivalent.

Every 10,000 running hours or 2 years whichever is less, the bearings, gears and seals should be inspected and the lubrication replaced. Under tropical or other arduous conditions, however, more frequent lubrication may be necessary. It is therefore advisable to establish a suitable maintenance schedule or periodic inspection to match service conditions.

Installation, Operation & Maintenance Instructions

2.0 START-UP PROCEDURE



By the nature of the equipment and its operating environment the Discam can be an extremely dangerous machine. It is vital that operators are conversant with these Operation and Maintenance Instructions prior to working with the machine.

Where applicable:

- 1) Check the foundation bolts are secure once the machine is installed in its correct operating position.
- 2) Check the gearbox lubricant, remove the plug and fit the air vent to prevent gearbox pressurisation. Not applicable to submersible drive units.
- 3) Check all electrical connections for continuity and earthing and that installation is in accordance with relevant regulations and circuit diagrams.
- 4) Always ensure that machine is guarded in accordance with PD5304: 2000 Safety of Machinery requirements before any attempt is made to operate.
- 5) On start-up check the direction of rotation
The cutters should rotate towards the centre when viewed from the inlet side.
Discs should rotate towards the cutters when viewed from the inlet side.



NOTE:



If it is necessary to remove any inspection cover to observe the action – EXTREME CARE should be observed when carrying out this procedure.

- 6) Check that the Muncher stops when "STOP" button(s) are activated.
- 7) Check for reverse rotation of cutters when "REVERSE" button is activated.
- 8) Start up the machine. On initial start-up, allow machine to run for approximately 45 minutes.

- 10) After a further 10 minutes of running, stop the machine, switch off and lock the main isolator. Check the tightness of all securing bolts. Re-check every 500 hours of operating time.
- 11) Check the tightness of all cables and connections. Re-check every 500 hours of operating time.
- 12) Observe manufacturers guidelines with regard to gearbox lubricant initial renewal and subsequent intervals.
- 13) In the event of machine overload (jam), the controller is programmed to protect the discam from overload. Details of the control philosophy are given in this section.
- 14) After machine shutdown, isolate and lock off. Inspect machine, removing any obstruction and press the "RESET" button.
- 15) The machine can now be re-started as 9) above.

NOTE:



NEVER inspect or work on or near the cutter chamber without first isolating and locking the machine.

Installation, Operation & Maintenance Instructions

3.0 DISMANTLING AND ASSEMBLY

Section 3 contains the steps to dismantle and re-assemble the Discam. All fastenings must be tightened securely and where identified the appropriate torque figures should be used.

3.1 USE OF ITEMS NOT APPROVED OR MANUFACTURED BY MONOFLO

The Muncher and its components have been designed to ensure that the machine will operate safely within the guidelines covered by the legislation.

As a consequence Monoflo have declared the machine safe to use for the duty specified.

The use of replacement items that are not approved by or manufactured by Monoflo may affect the safe operation of the machine and it may therefore become a safety hazard to both operators and other equipment. In these instances the Declaration provided will therefore become invalid. The guarantee referenced in the Terms and Conditions of Sale will also be invalidated if replacement items are used that are not approved or manufactured by Monoflo.

3.2 DISMANTLING ADVICE (Refer to specified drawings).

CAUTION: When servicing the Discam, be certain that the mains isolator is off and padlocked. Serious injury could result from accidental start-up.

- 1) Disconnect wiring at motor(s) terminal box(es) and tag leads for identification.
- 2) If necessary, the Discam may be completely removed from installation using the recommended lifting equipment.
- 3) When dismantling cutters and spacers, take careful note of the position and orientation of each component.

3.3 CLEANING / INSPECTION

- 1) Steam clean and disinfect all parts of the Muncher excluding motor, seal assemblies, gear drive unit and bearings.
- 2) Remove any gasket material from joint faces.
- 3) Housings should be cleaned thoroughly.
- 4) Inspect all parts for excessive wear and replace if necessary.
- 5) Sealed bearings cannot be re-greased, replace if necessary.
- 6) Check and if necessary replace the internal 'O'-rings, lipseals and mechanical seals.
- 7) Inspect gears for wear and damage and replace if necessary.
- 8) All cutters and spacers must be clean and free from cracks or excessive wear.
- 9) Shafts should be clean and any burrs filed off for easier stacking. Inspect shafts for excessive wear of hexagonal portion. Replace if necessary.

3.4 REASSEMBLY ADVICE

- 1) Lubricate all bores, shafts and seals on re-assembly.
- 2) Lubricate gears on re-assembly with the specified lubricant.
- 3) Reconnect wiring at motor(s) terminal box(es) using tag leads for identification.
- 4) On completion of assembly, run through the 'initial start-up' procedure in section 2.

Wiring Diagram

Please contact Monoflo

Dismantling Diagrams

Muncher Module

1

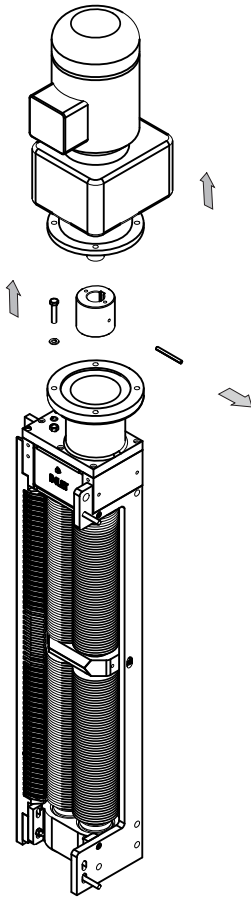

2

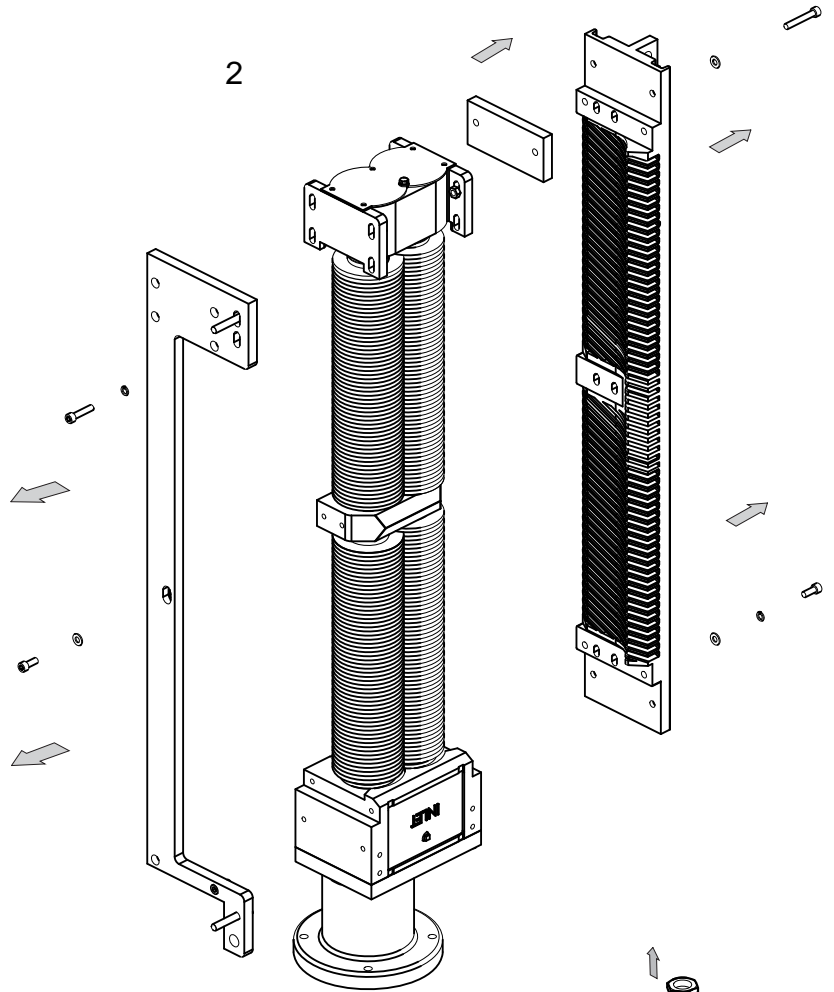

3

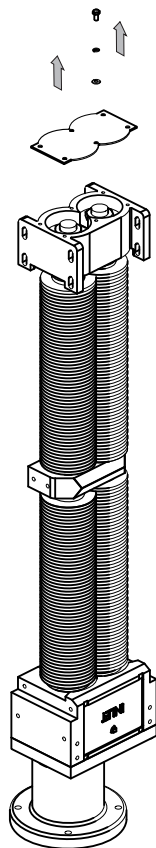

4

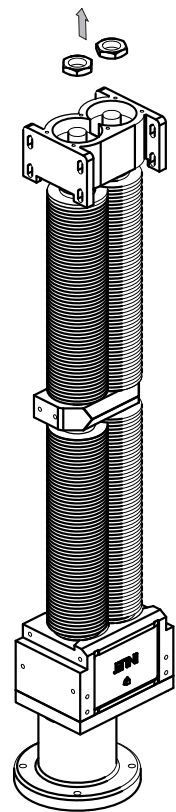

Dismantling Diagrams

Muncher Module

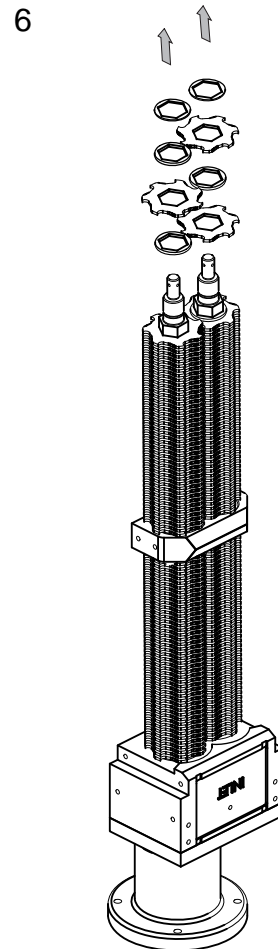
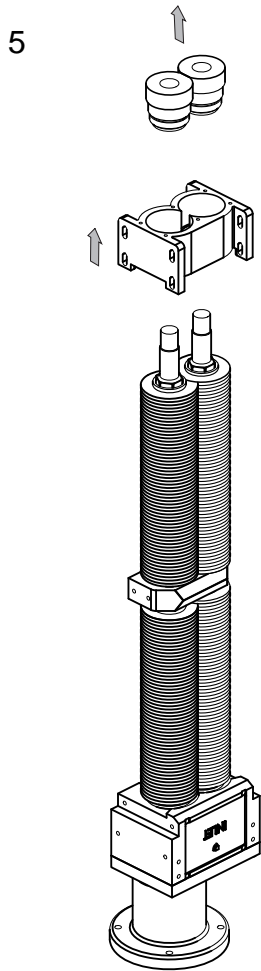

Quantity & part number is dependent on model

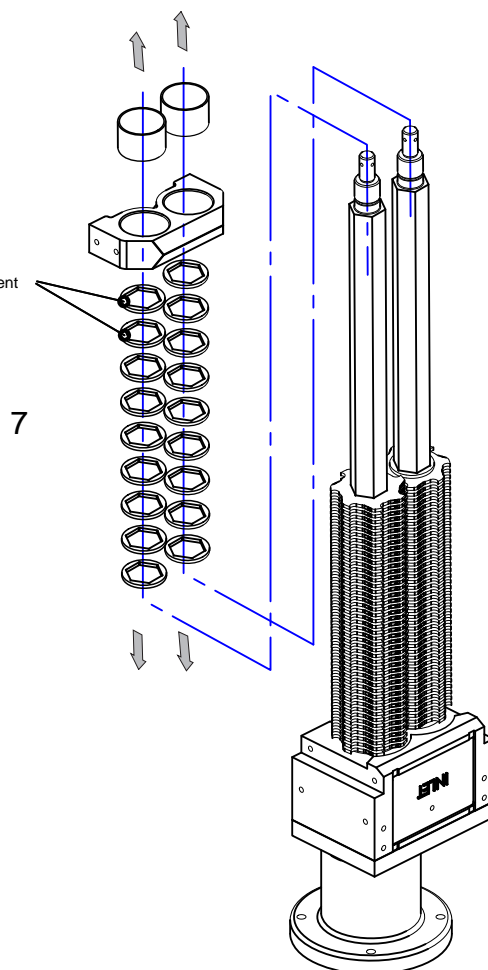

Dismantling Diagrams

Muncher Module

8

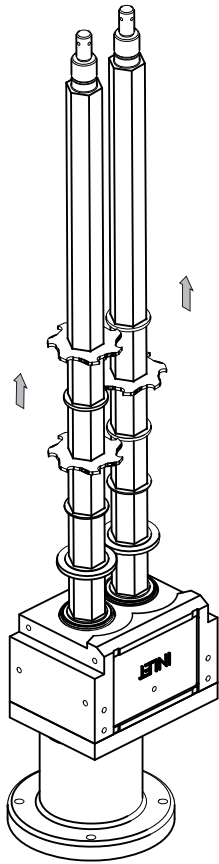

9

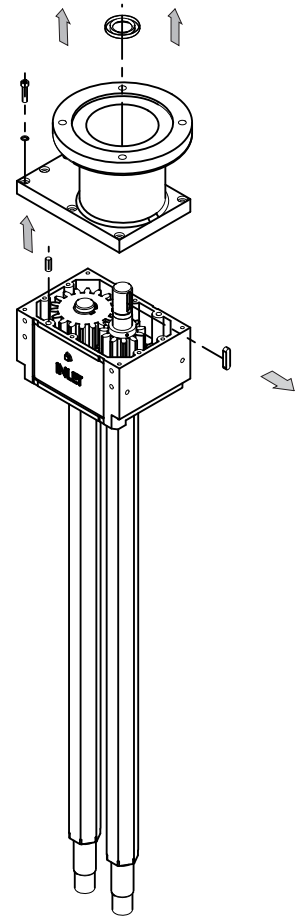

10

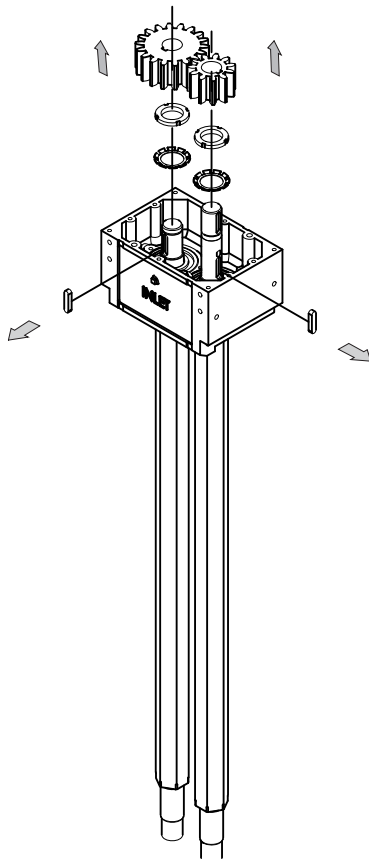

11

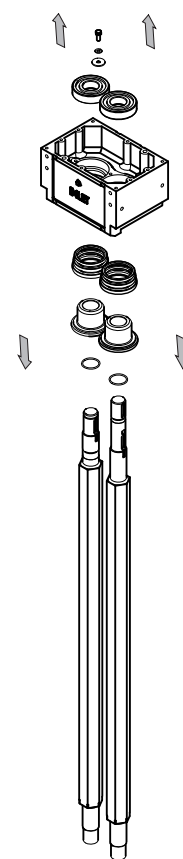

Dismantling Diagrams

Discreen Module

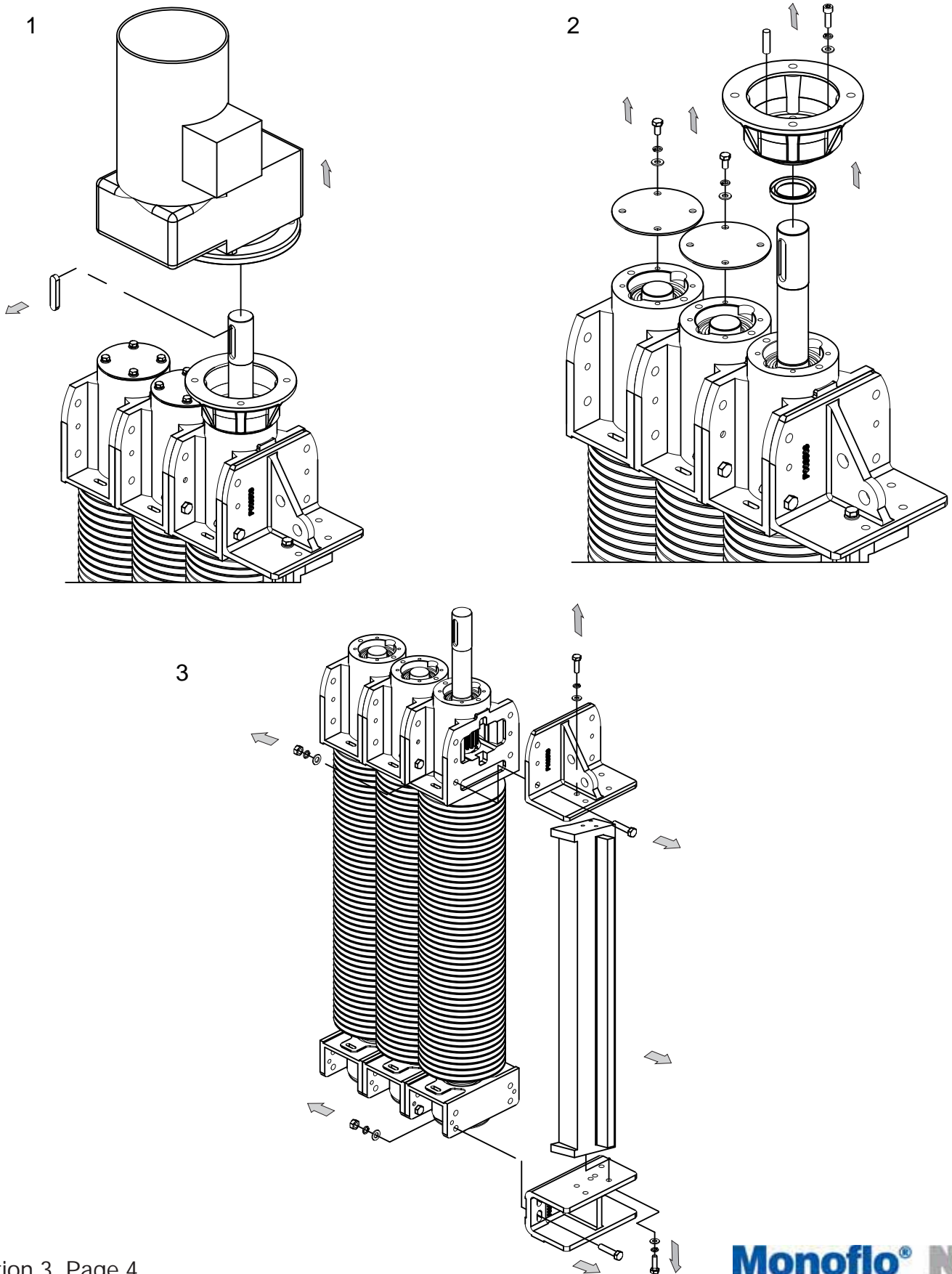

Dismantling Diagrams

Discreen Module

4

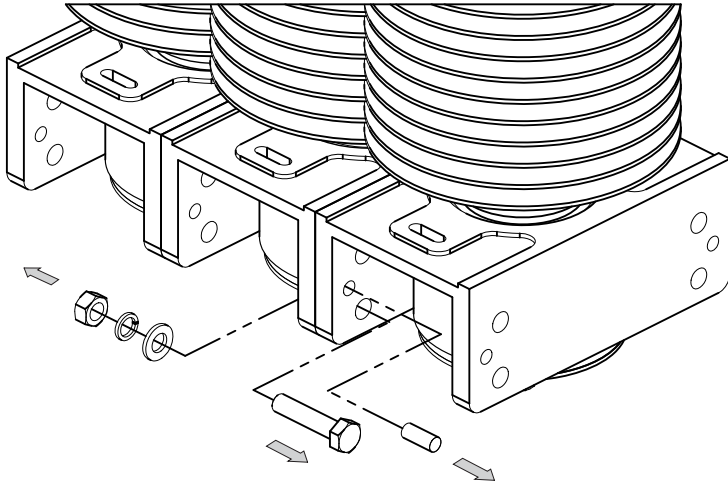

5

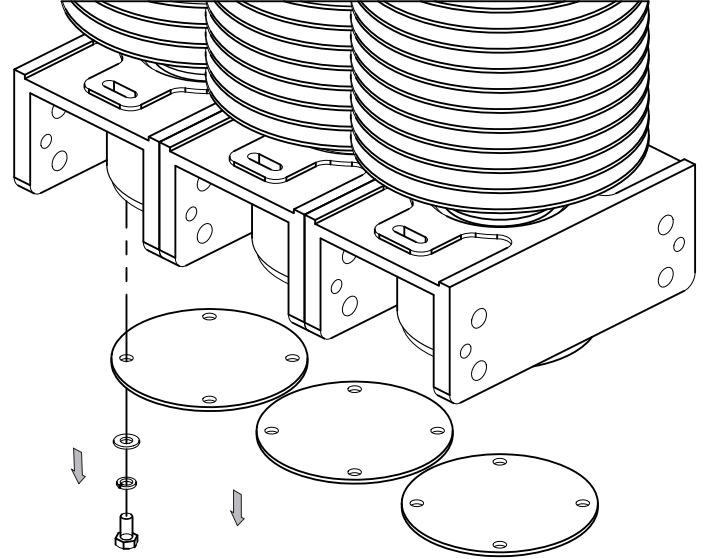

6

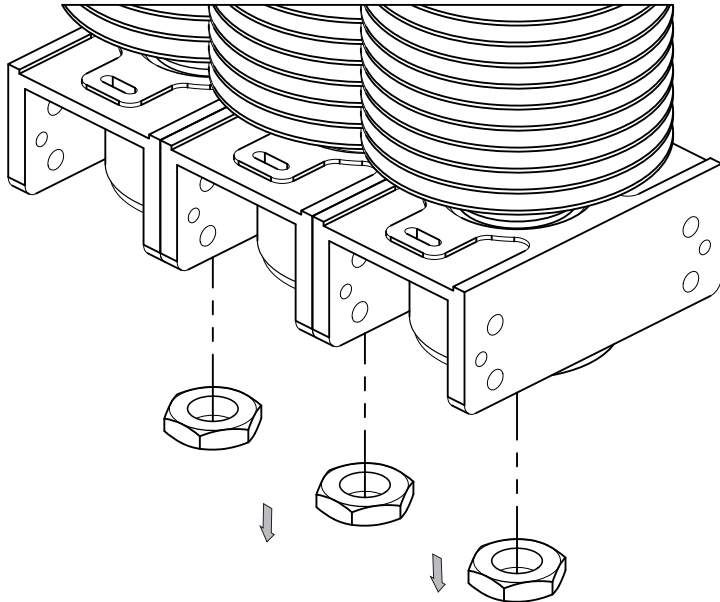

7

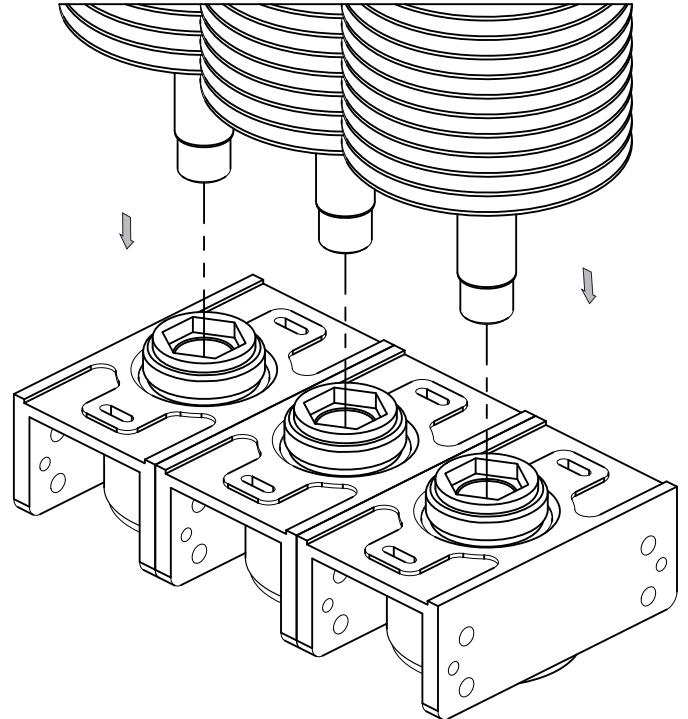

Dismantling Diagrams

Discreen Module

8

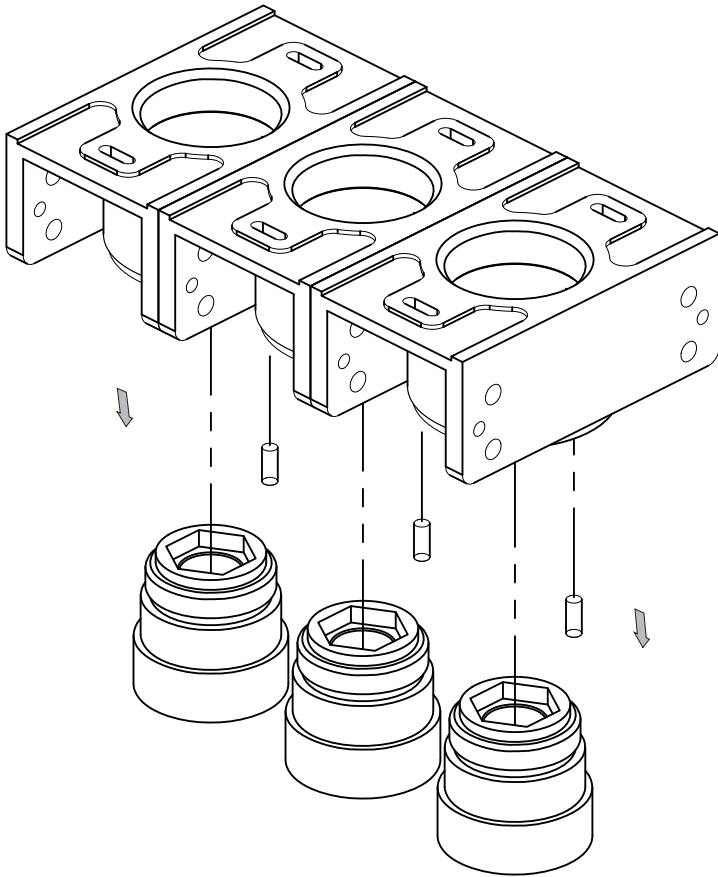

9

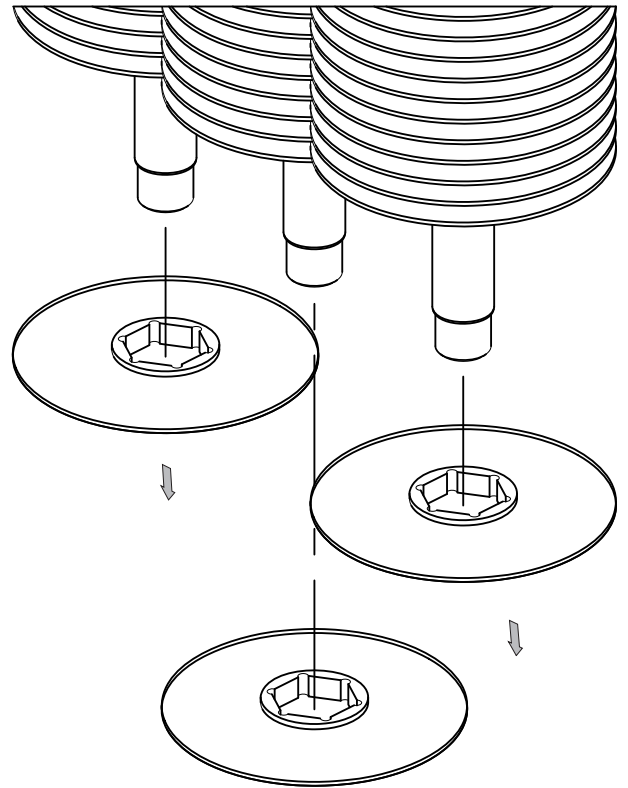

10

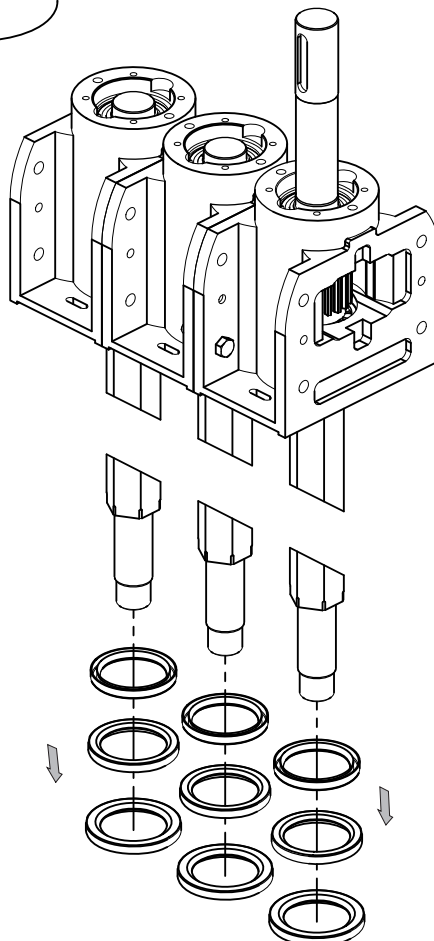

Dismantling Diagrams

Discreen Module

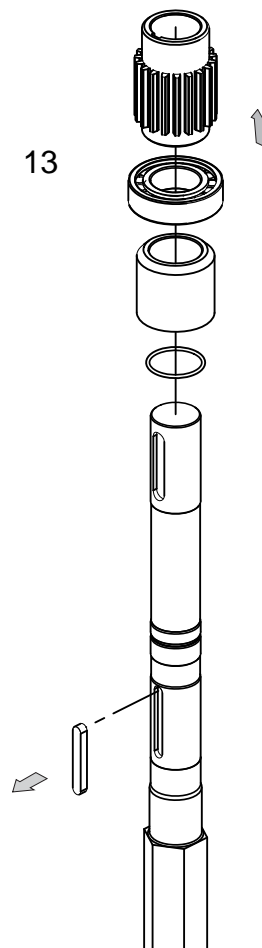
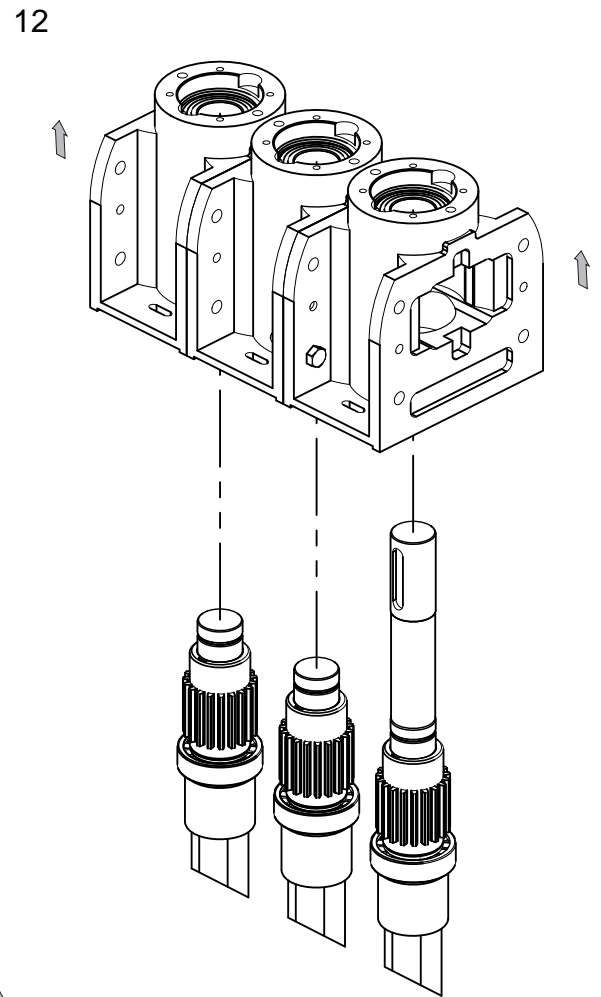
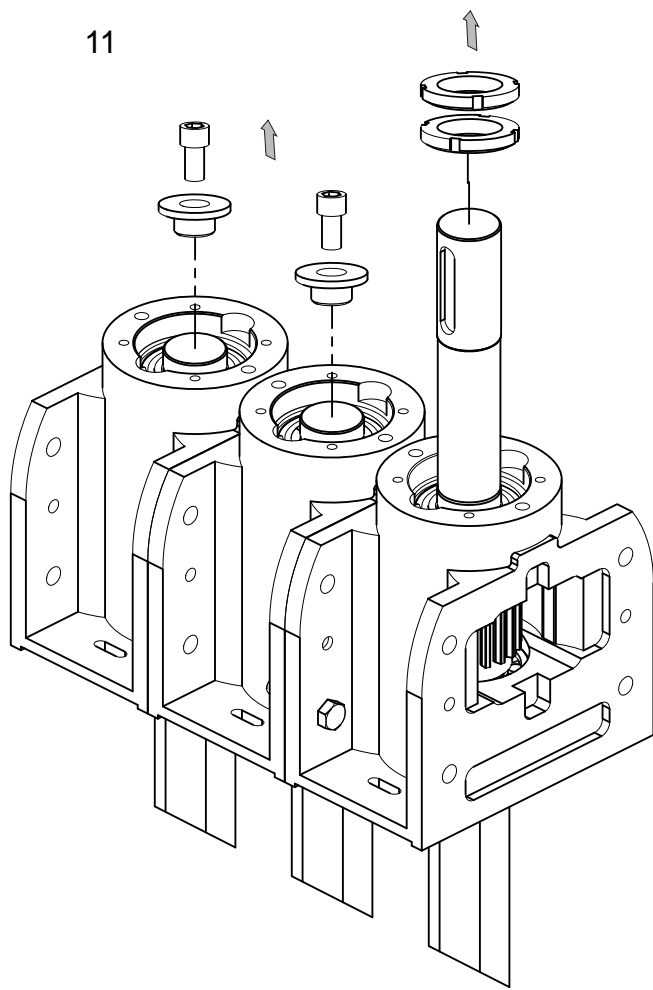

Dismantling Diagrams

Discreen Module

14

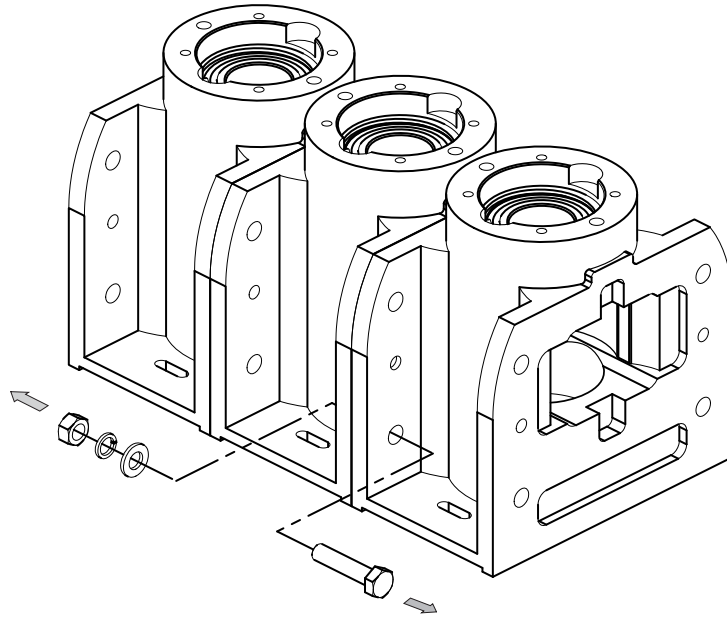

15

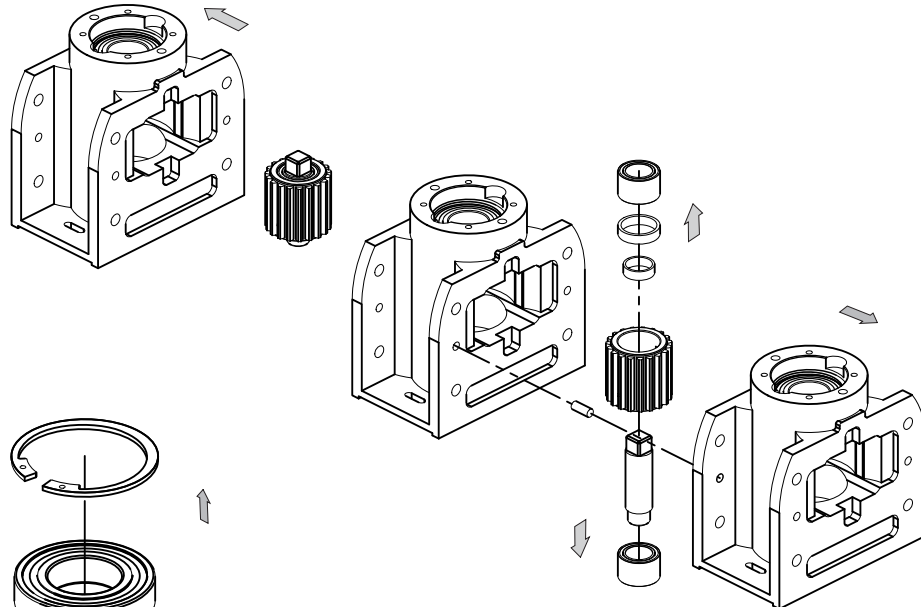

16

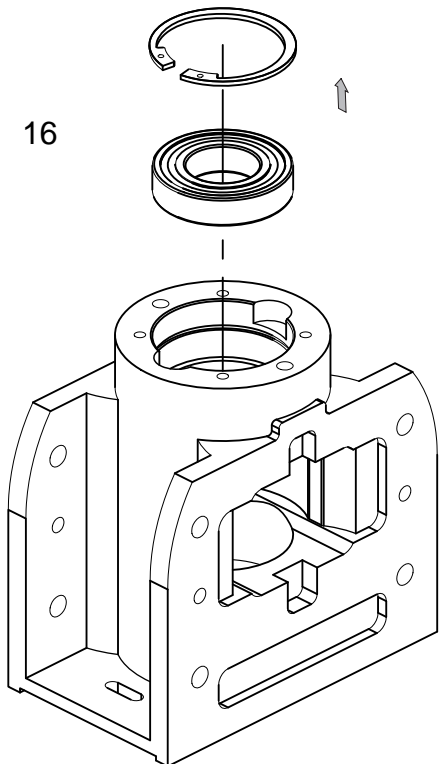

Assembly Diagrams

Muncher Module

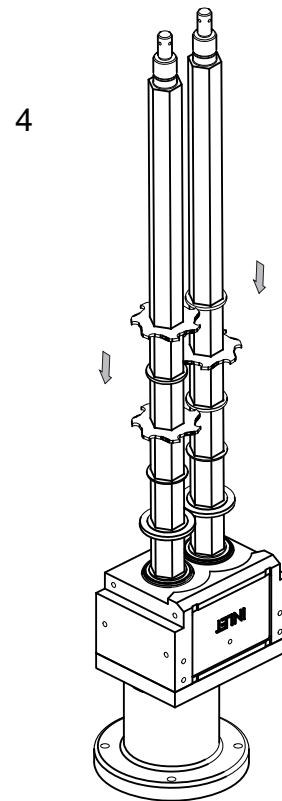
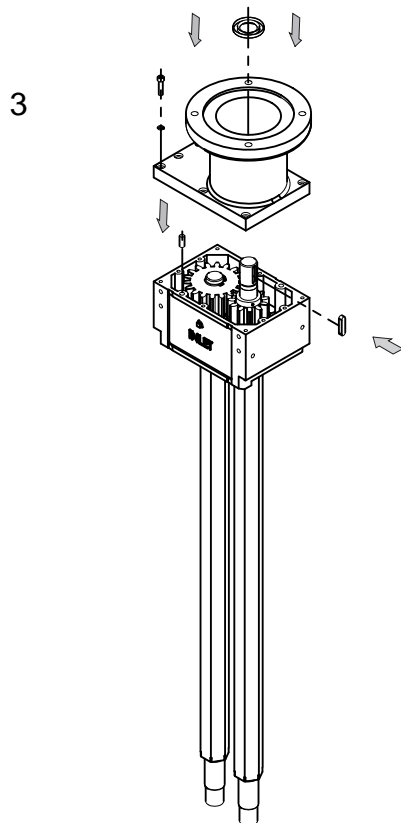
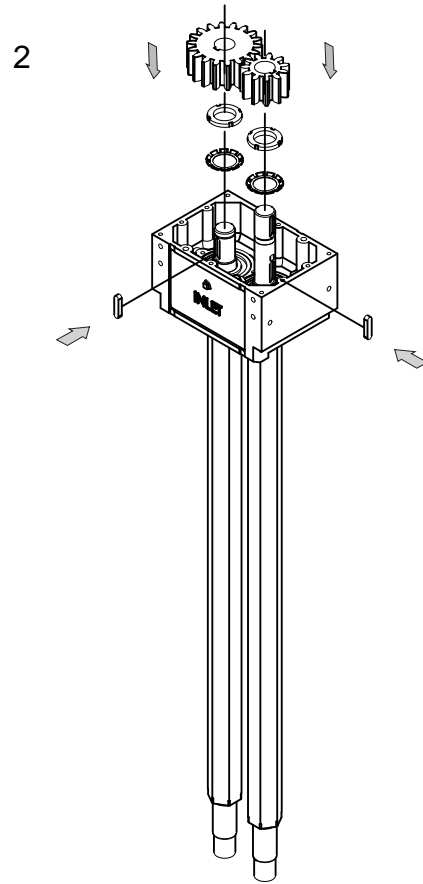
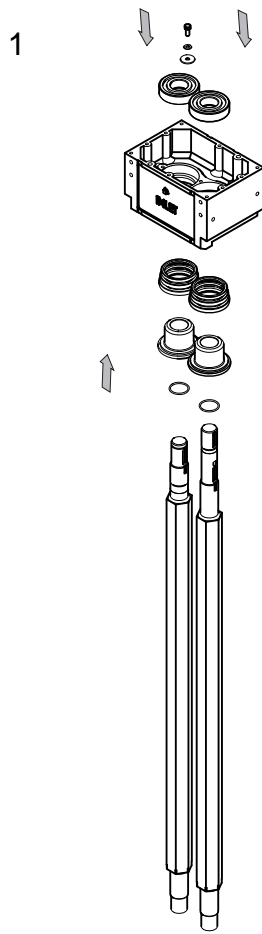

Assembly Diagrams

Muncher Module

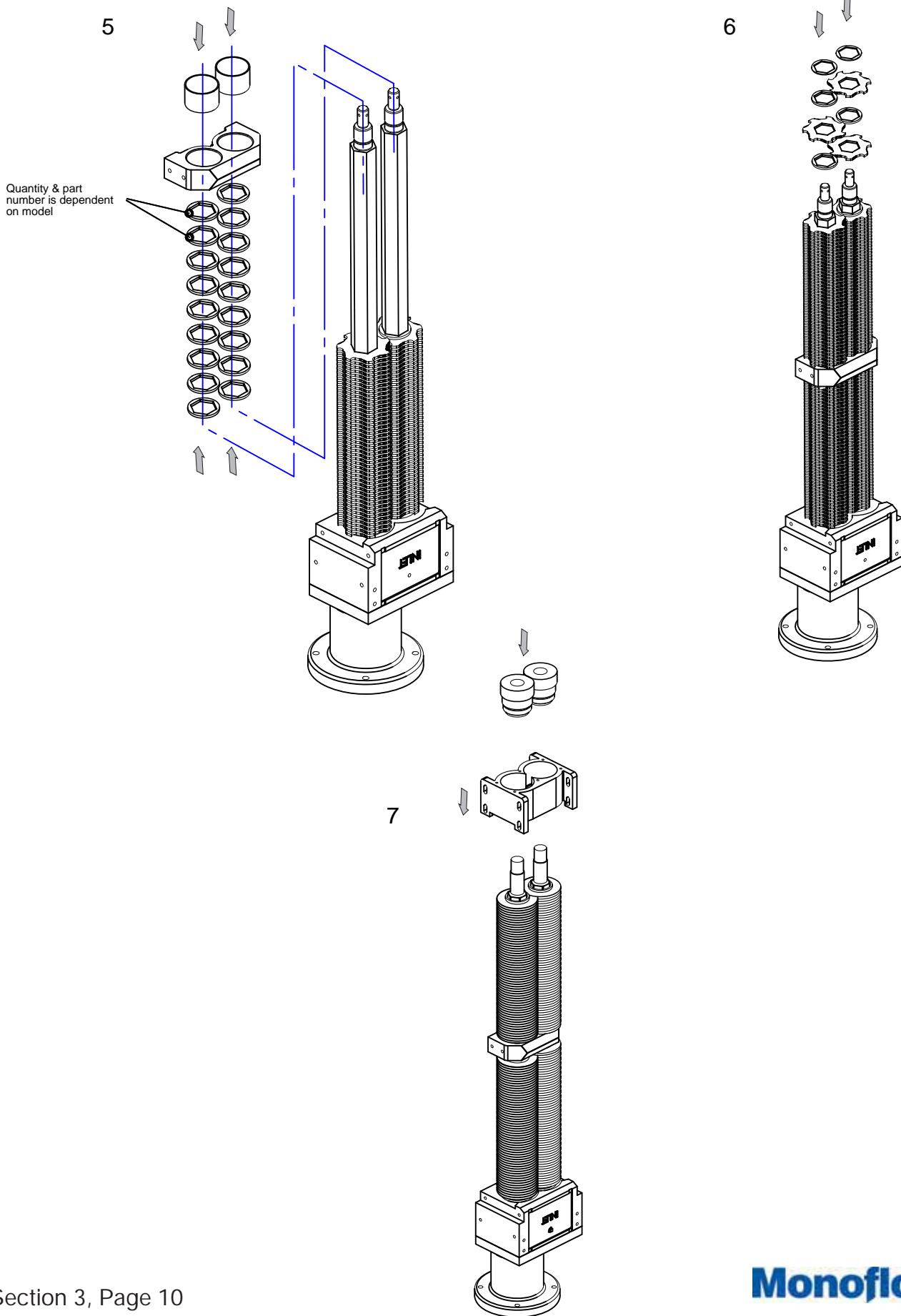

Assembly Diagrams

Muncher Module

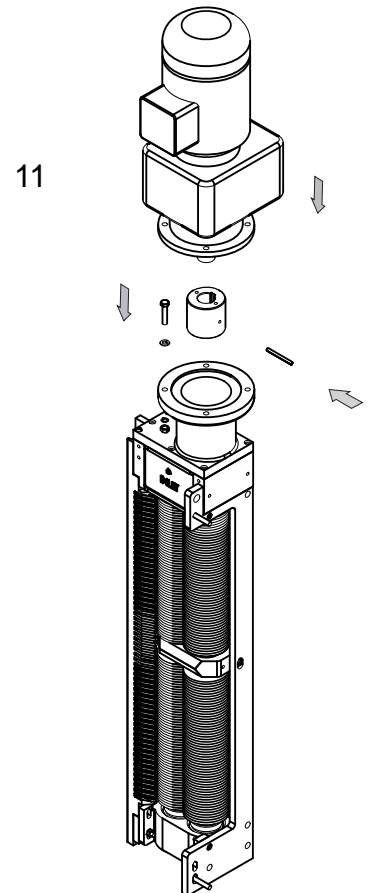
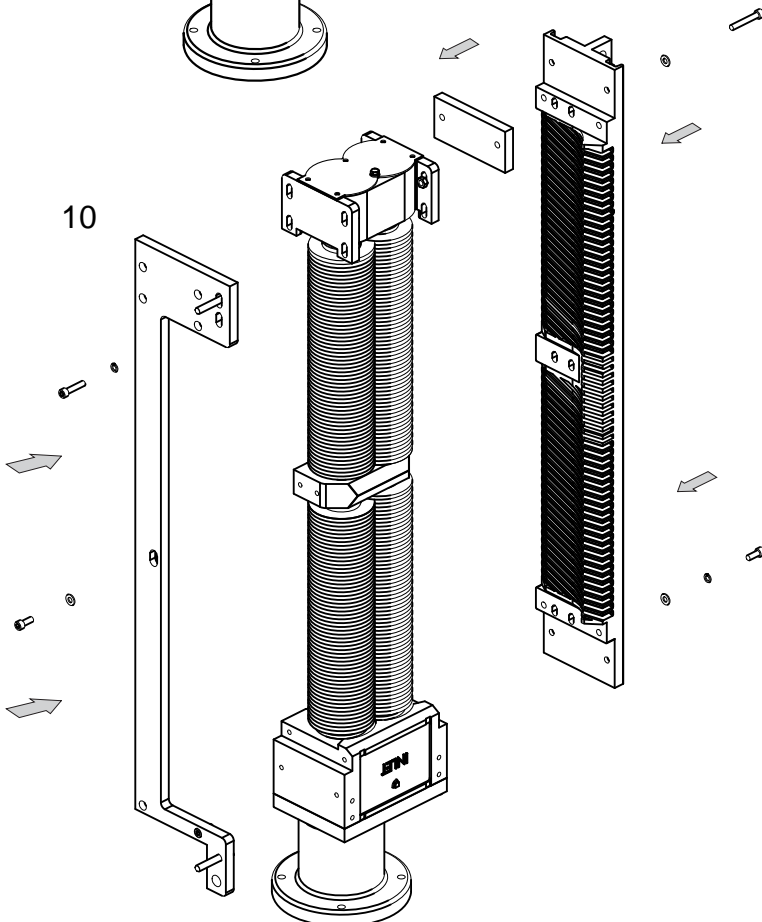
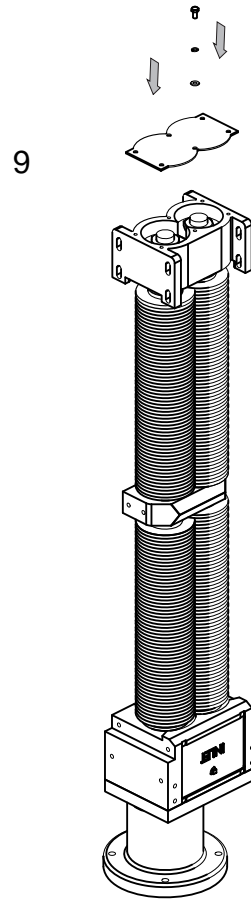
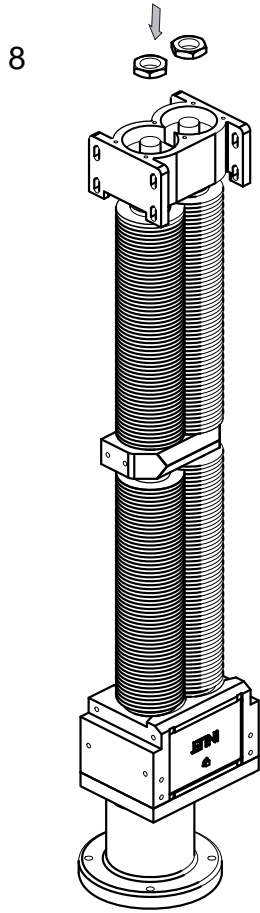

Assembly Diagrams

Discreen Module

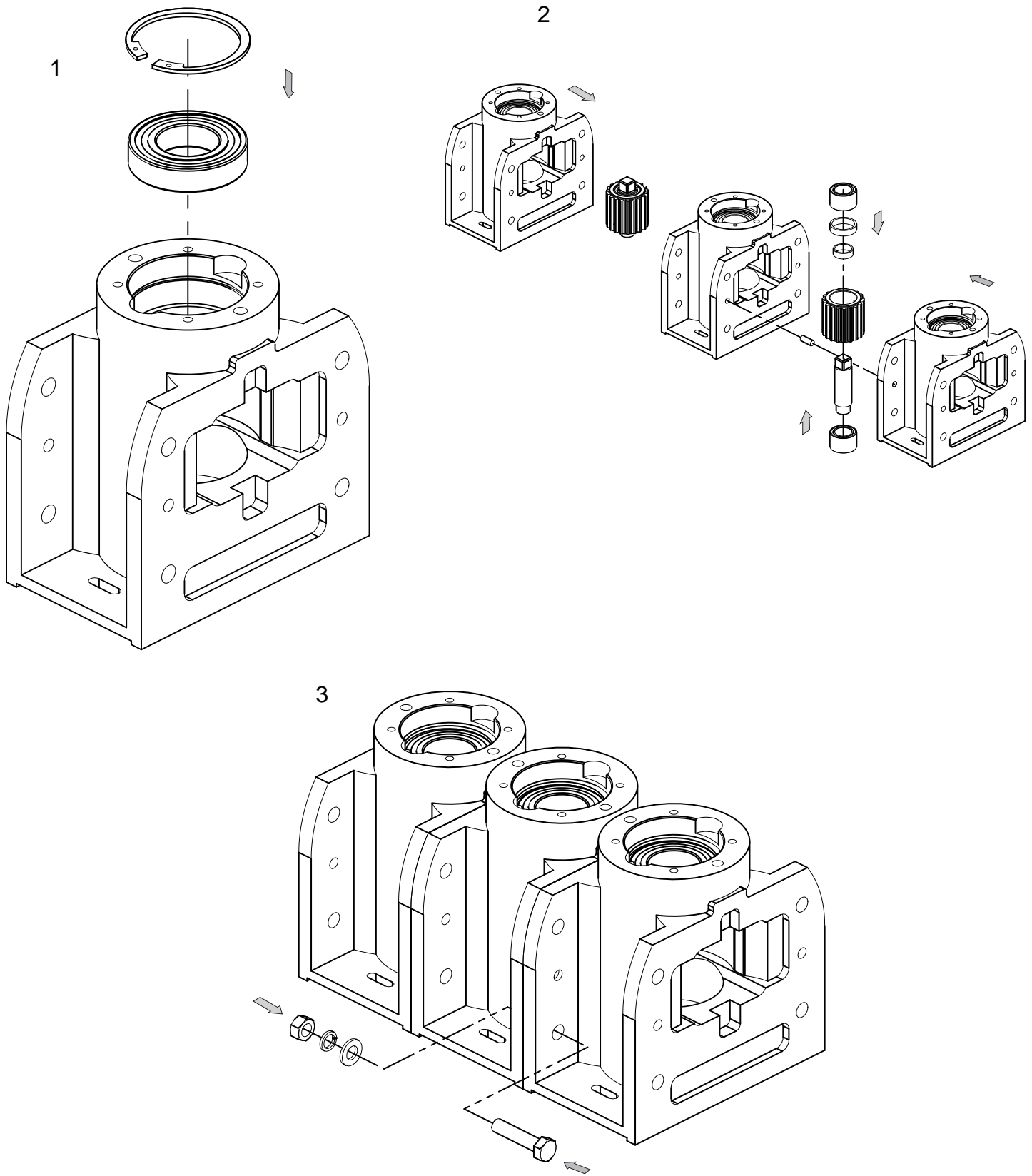

Assembly Diagrams

Discreen Module

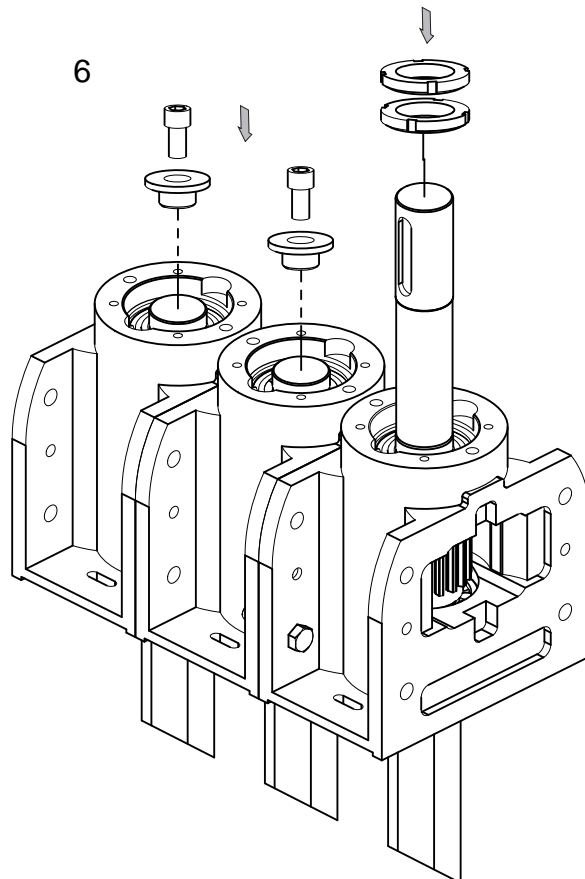
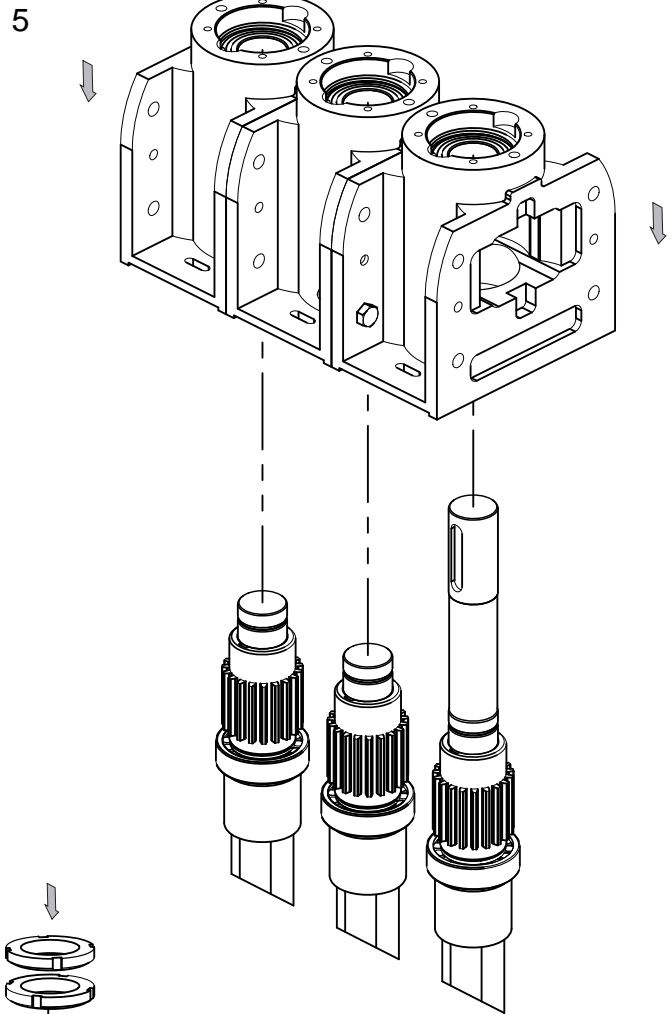
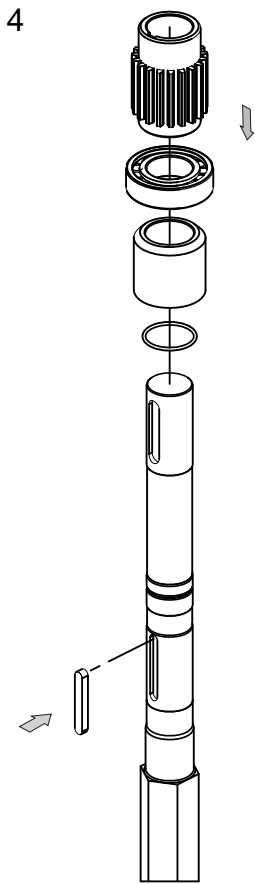

Assembly Diagrams

Discreen Module

7

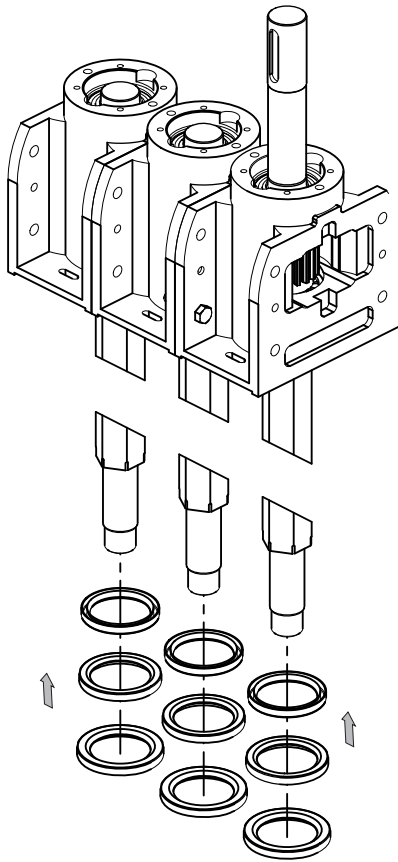

8

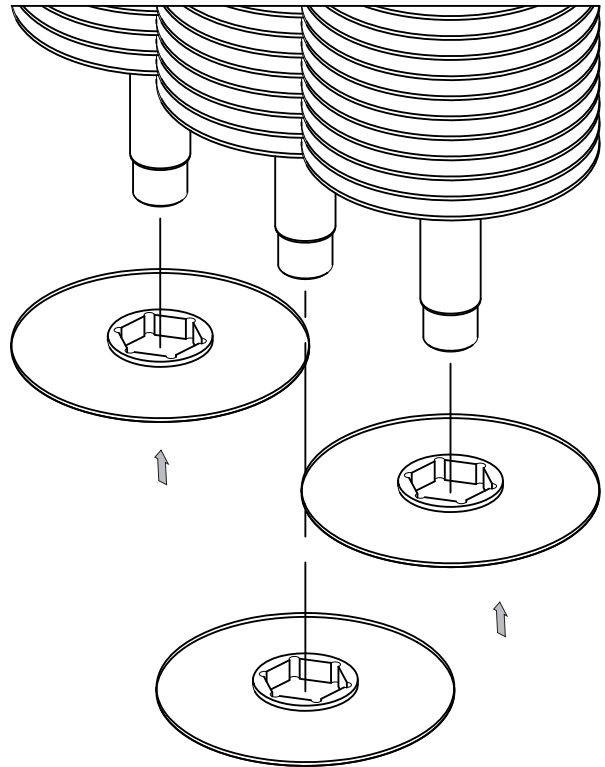

9

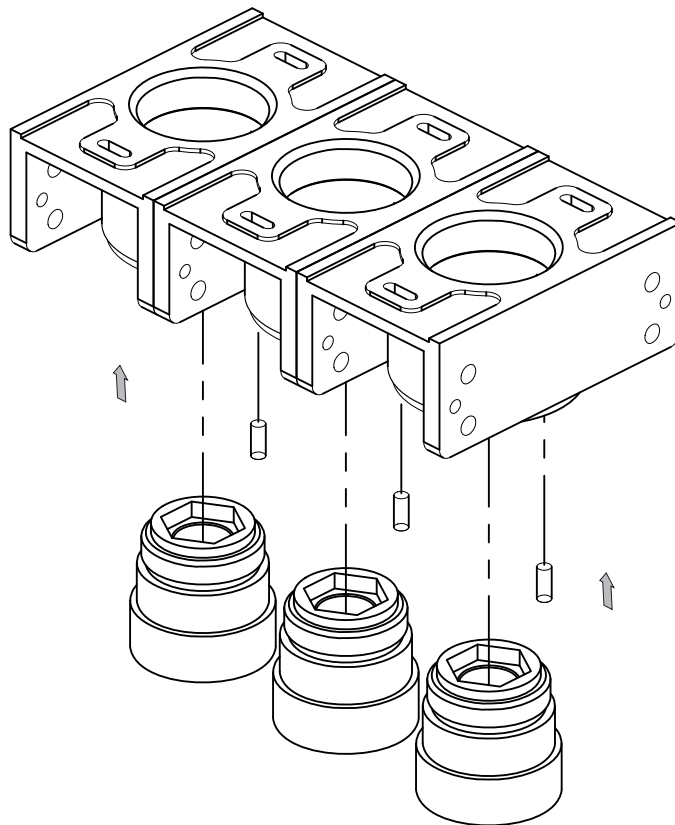

Assembly Diagrams

Discreen Module

10

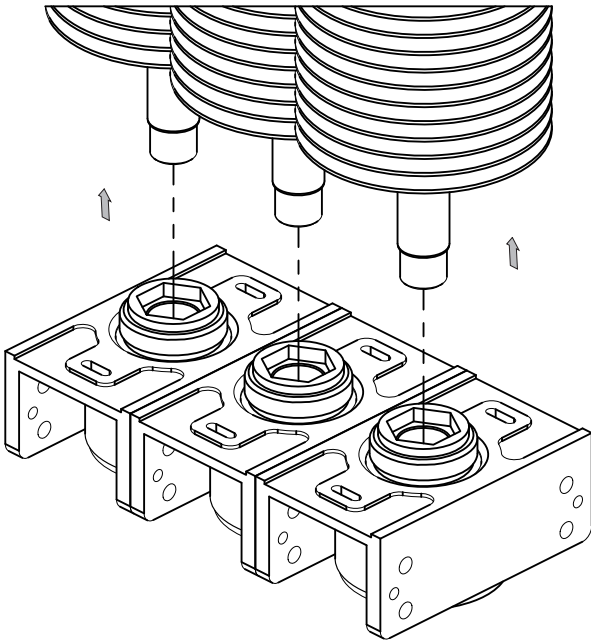

11

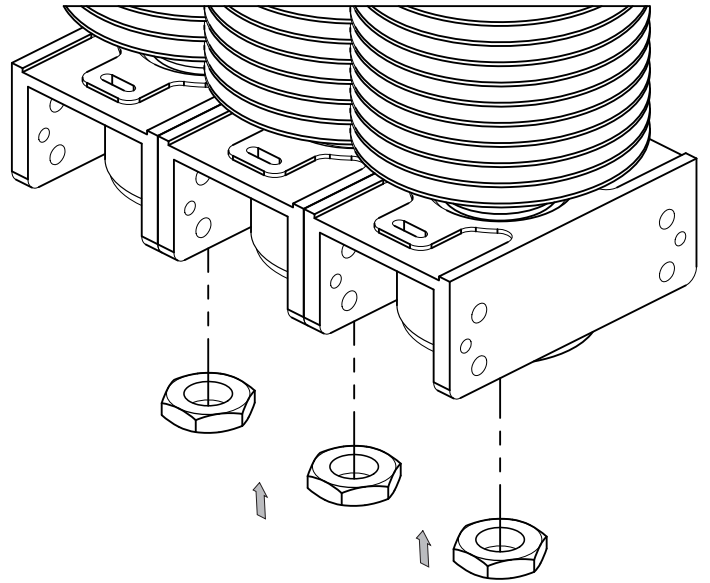

12

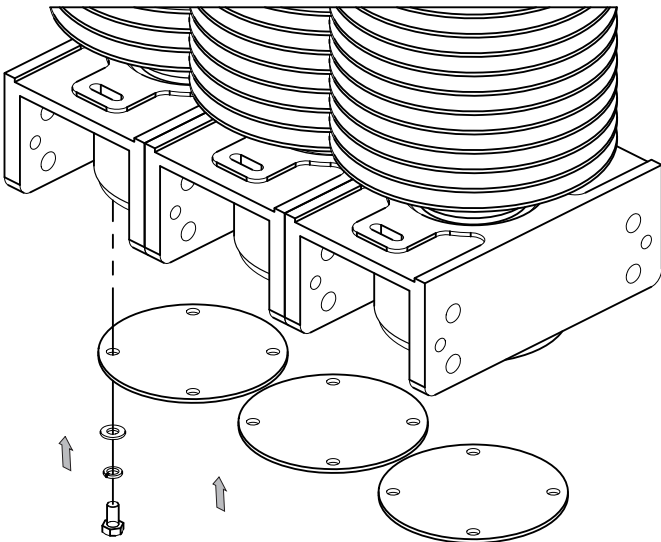

13

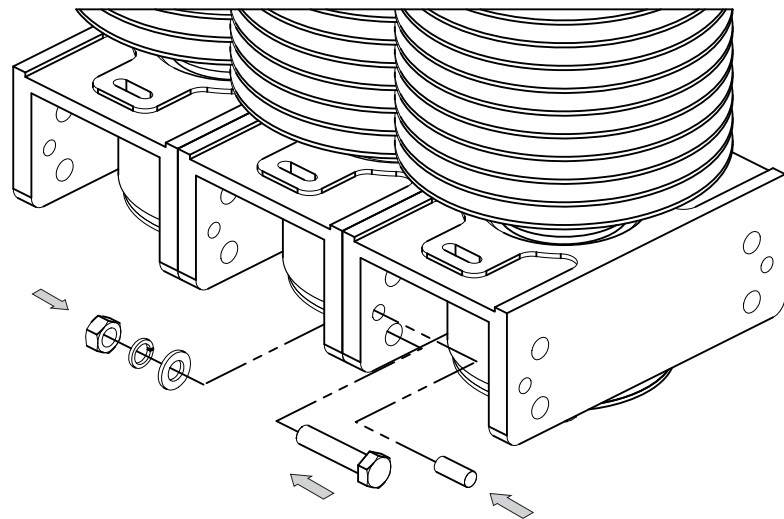

Assembly Diagrams

Discreen Module

14

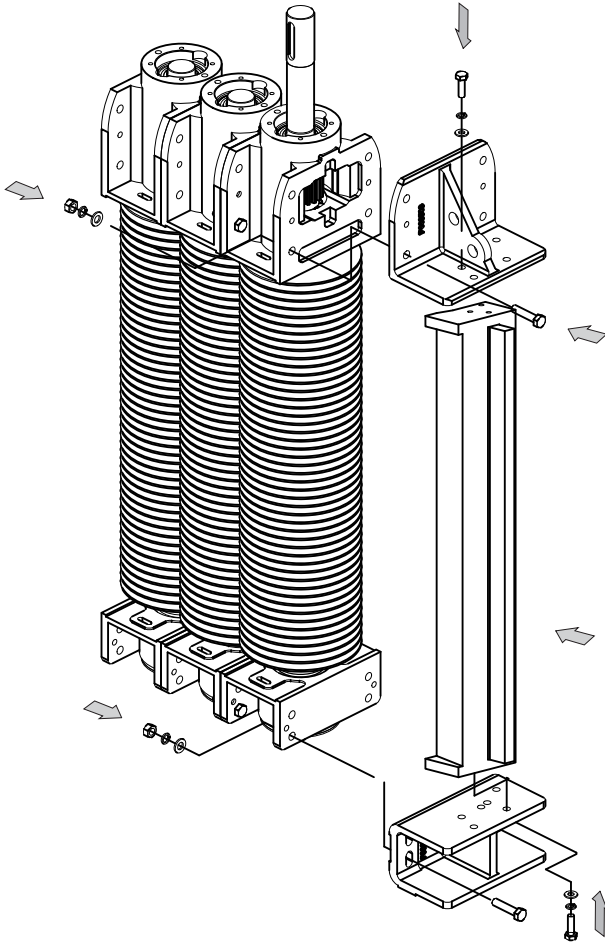

15

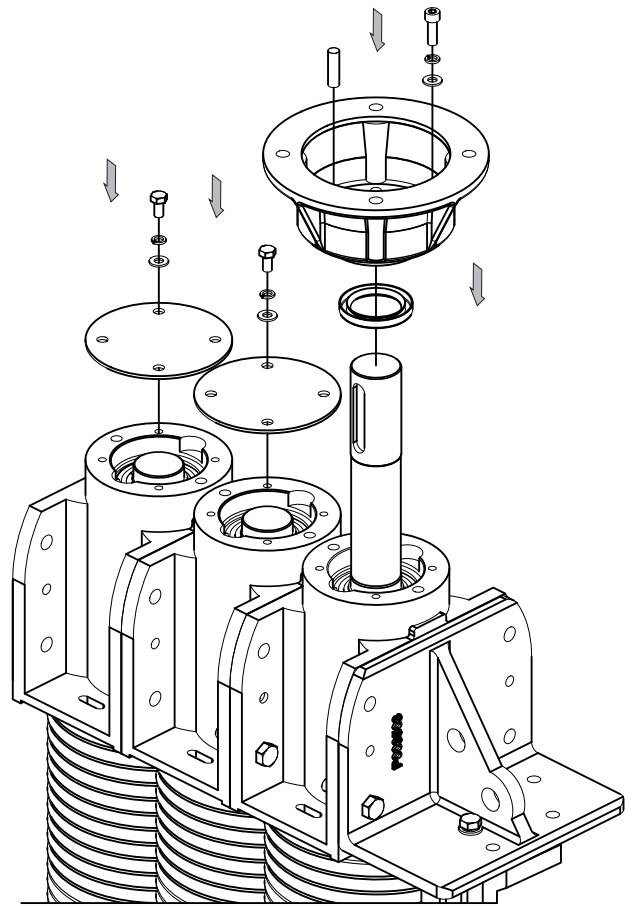

16

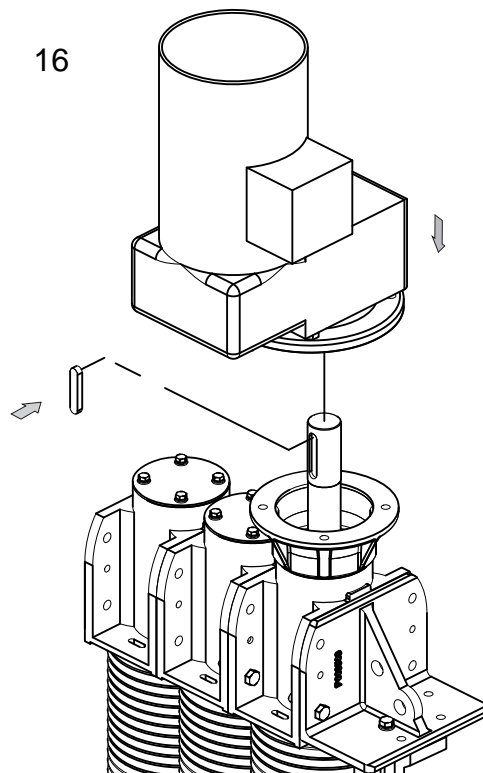

Build Up - Muncher 'O' Rings

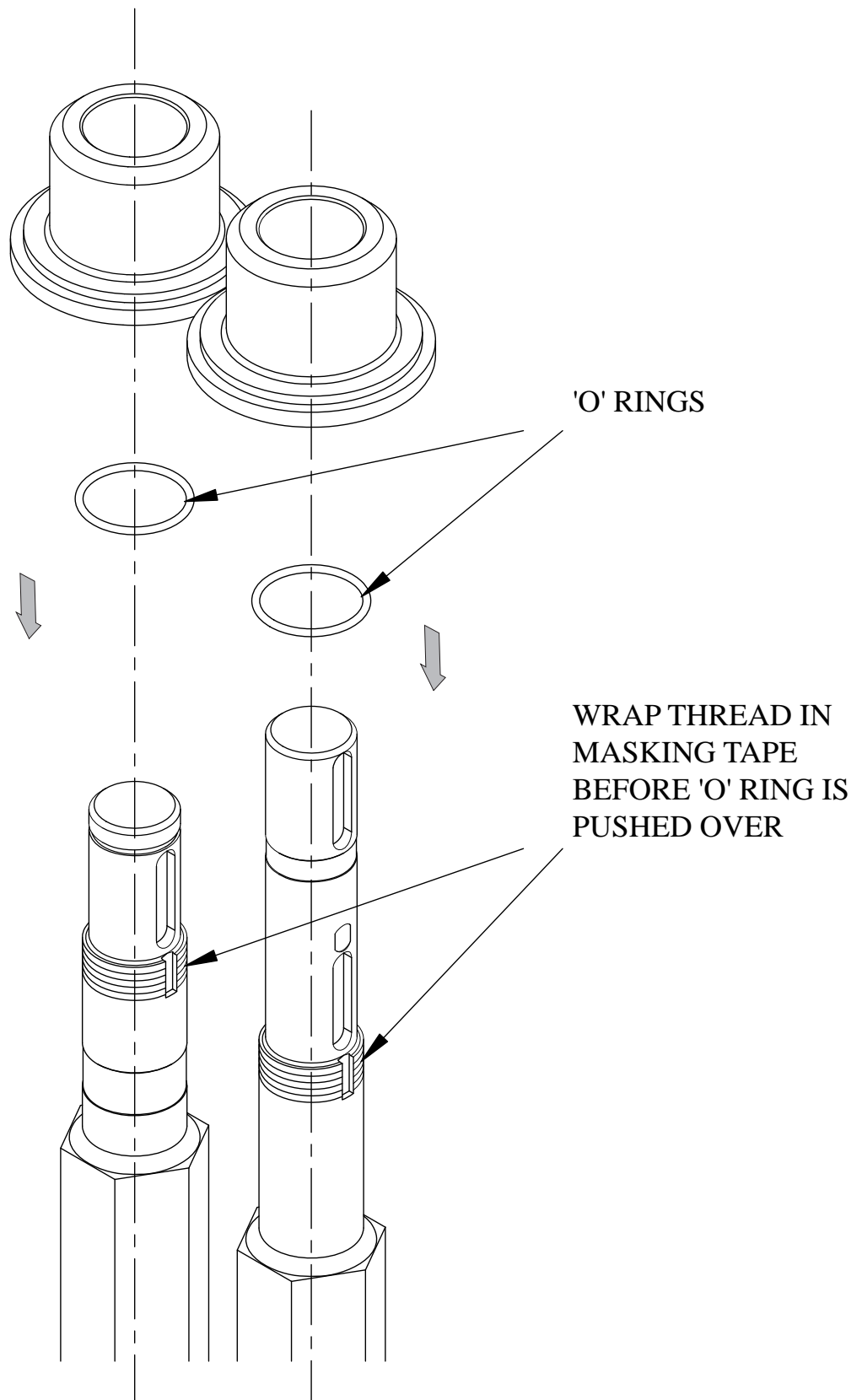

9mm (0.35") DISCREEN DISC SPACER BUILD UP ONLY
EXAMPLE - 5 SHAFT CONFIGURATION

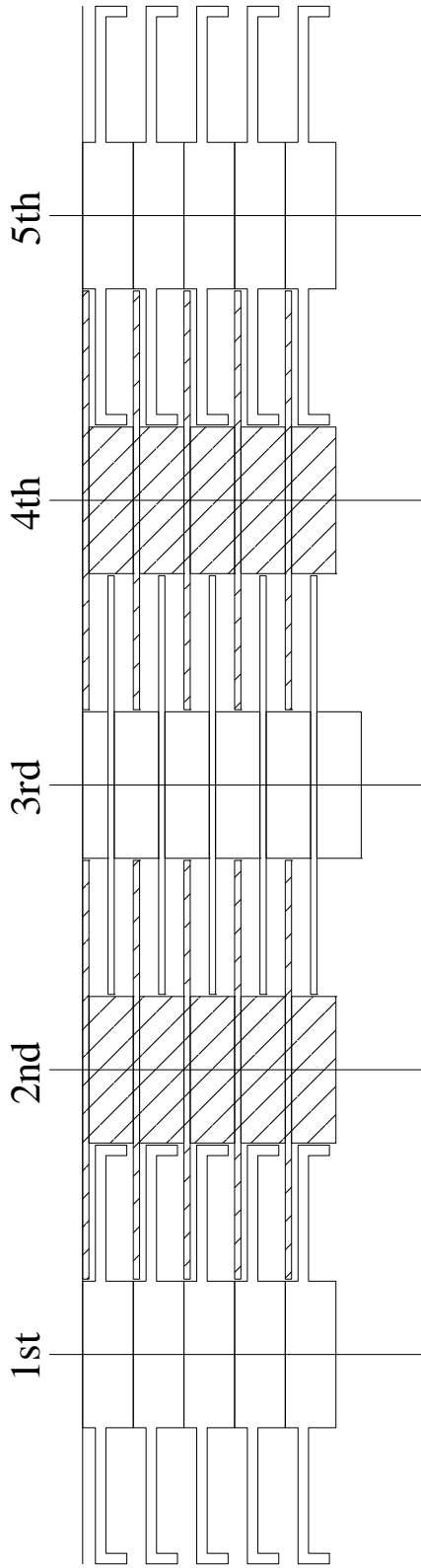

9mm (0.35") DISCREEN DISC SPACER BUILD UP ONLY
EXAMPLE - 4 SHAFT CONFIGURATION

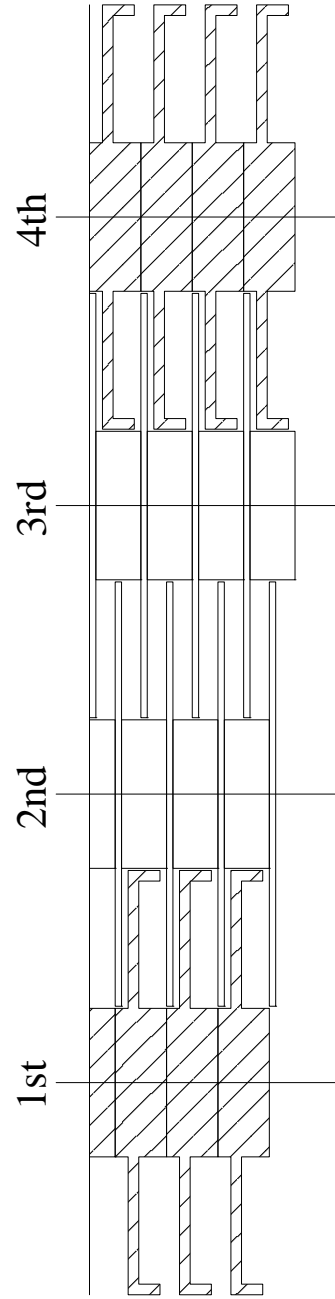

Build Up - 9mm (0.35'') Spacing

1M THROAT

SHAFT CONFIGURATION														
1st			2nd			3rd (Drive)			4th			5th		
MATL.	DRG.No.	QTY	MATL.	DRG.No.	QTY	MATL.	DRG.No.	QTY	MATL.	DRG.No.	QTY	MATL.	DRG.No.	QTY
SO	D000 2502	41	SO	D000 2500	41	SO	D000 3551	1	SO	D000 2500	41	SO	D000 2502	41
			SO	D000 3550	41	SR	A02A 3504	1	SO	D000 3550	41			
			SO	D000 3551	41	SO	D000 2500	41	SO	D000 3551	41			
						SO	D000 3550	40						
						SO	D000 3551	40						
						SR	D000 3504	1						

Example - 5 shaft

For a 3 shaft machine - TAKE OUT (columns 3 & 4)

For a 7 shaft machine - ADD (columns 3 & 4) x 1

For a 9 shaft machine - ADD (columns 3 & 4) x 2

SHAFT CONFIGURATION														
1st			2nd			3rd (Drive)			4th			5th		
MATL.	DRG.No.	QTY	MATL.	DRG.No.	QTY	MATL.	DRG.No.	QTY	MATL.	DRG.No.	QTY	MATL.	DRG.No.	QTY
SO	D000 3551	1	SO	D000 3551	1	SO	D000 2500	41	SO	D000 2502	41			
SR	A02A 3504	1	SR	A02A 3504	1	SO	D000 3550	41						
SO	D000 2502	40	SO	D000 2500	41	SO	D000 3551	41						
SO	D000 3551	1	SO	D000 3550	40									
SR	A02A 3504	1	SO	D000 3551	40									
			SR	D000 3504	1									

Example - 4 shaft

For a 6 shaft machine - ADD (columns 2 & 3) x 1

For a 8 shaft machine - ADD (columns 2 & 3) x 2

For a 10 shaft machine - ADD (columns 2 & 3) x 3

1.5M THROAT

SHAFT CONFIGURATION														
1st			2nd			3rd (Drive)			4th			5th		
MATL.	DRG.No.	QTY	MATL.	DRG.No.	QTY	MATL.	DRG.No.	QTY	MATL.	DRG.No.	QTY	MATL.	DRG.No.	QTY
SO	D000 2502	62	SO	D000 2500	62	SO	D000 3551	1	SO	D000 2500	62	SO	D000 2502	62
SR	A02A 3505	1	SO	D000 3550	62	SR	A02A 3504	1	SO	D000 3550	62	SR	A02A 3505	1
			SO	D000 3551	62	SO	D000 2500	61	SO	D000 3551	62			
			SR	A02A 3503	1	SO	D000 3550	61	SR	A02A 3503	1			
						SO	D000 3551	61						
						SO	D000 2500	1						
						SR	A02A 3503	1						
						SR	D000 3504	1						

Example - 5 shaft

For a 3 shaft machine - TAKE OUT (columns 3 & 4)

For a 7 shaft machine - ADD (columns 3 & 4) x 1

For a 9 shaft machine - ADD (columns 3 & 4) x 2

SHAFT CONFIGURATION														
1st			2nd			3rd (Drive)			4th			5th		
MATL.	DRG.No.	QTY	MATL.	DRG.No.	QTY	MATL.	DRG.No.	QTY	MATL.	DRG.No.	QTY	MATL.	DRG.No.	QTY
SO	D000 3551	1	SO	D000 3551	1	SO	D000 2500	62	SO	D000 2502	62			
SR	A02A 3504	1	SR	A02A 3504	1	SO	D000 3550	62	SR	A02A 3505	1			
SO	D000 2502	61	SO	D000 2500	61	SO	D000 3551	62						
SR	A02A 3504	1	SO	D000 3550	61	SR	A02A 3503	1						
SR	A02A 3502	1	SO	D000 3551	61									
			SO	D000 2500	1									
			SR	A02A 3503	1									
			SR	D000 3504	1									

Example - 4 shaft

For a 6 shaft machine - ADD (columns 2 & 3) x 1

For a 8 shaft machine - ADD (columns 2 & 3) x 2

For a 10 shaft machine - ADD (columns 2 & 3) x 3

2M THROAT

SHAFT CONFIGURATION														
1st			2nd			3rd (Drive)			4th			5th		
MATL.	DRG.No.	QTY	MATL.	DRG.No.	QTY	MATL.	DRG.No.	QTY	MATL.	DRG.No.	QTY	MATL.	DRG.No.	QTY
SO	D000 2502	84	SO	D000 2500	84	SO	D000 3551	1	SO	D000 2500	84	SO	D000 2502	84
SR	D000 3504	1	SO	D000 3550	84	SR	A02A 3504	1	SO	D000 3550	84	SR	D000 3504	1
			SO	D000 3551	84	SO	D000 2500	83	SO	D000 3551	84			
			SO	D000 2500	1	SO	D000 3550	83	SO	D000 2500	1			
			SR	A02A 3500	1	SO	D000 3551	83	SR	A02A 3500	1			
			SR	A02A 3505	1	SO	D000 2500	1	SR	A02A 3505	1			
						SR	D000 3504	1						
						SR	L000 3501	1						

Example - 5 shaft

For a 3 shaft machine - TAKE OUT (columns 3 & 4)

For a 7 shaft machine - ADD (columns 3 & 4) x 1

For a 9 shaft machine - ADD (columns 3 & 4) x 2

SHAFT CONFIGURATION														
1st			2nd			3rd (Drive)			4th			5th		
MATL.	DRG.No.	QTY	MATL.	DRG.No.	QTY	MATL.	DRG.No.	QTY	MATL.	DRG.No.	QTY	MATL.	DRG.No.	QTY
SO	D000 3551	1	SO	D000 3551	1	SO	D000 2500	84	SO	D000 2502	84			
SR	A02A 3504	1	SR	A02A 3504	1	SO	D000 3550	84	SR	D000 3504	1			
SO	D000 2502	84	SO	D000 2500	83	SO	D000 3551	84						
			SO	D000 3550	83	SO	D000 2500	1						
			SO	D000 3551	83	SR	A02A 3500	1						
			SO	D000 2500	1	SR	A02A 3505	1						
			SR	D000 3504	1									
			SR	L000 3501	1									

Example - 4 shaft

For a 6 shaft machine - ADD (columns 2 & 3) x 1

For a 8 shaft machine - ADD (columns 2 & 3) x 2

For a 10 shaft machine - ADD (columns 2 & 3) x 3

5mm (0.19") DISCREEN DISC SPACER BUILD UP ONLY
EXAMPLE - 5 SHAFT CONFIGURATION

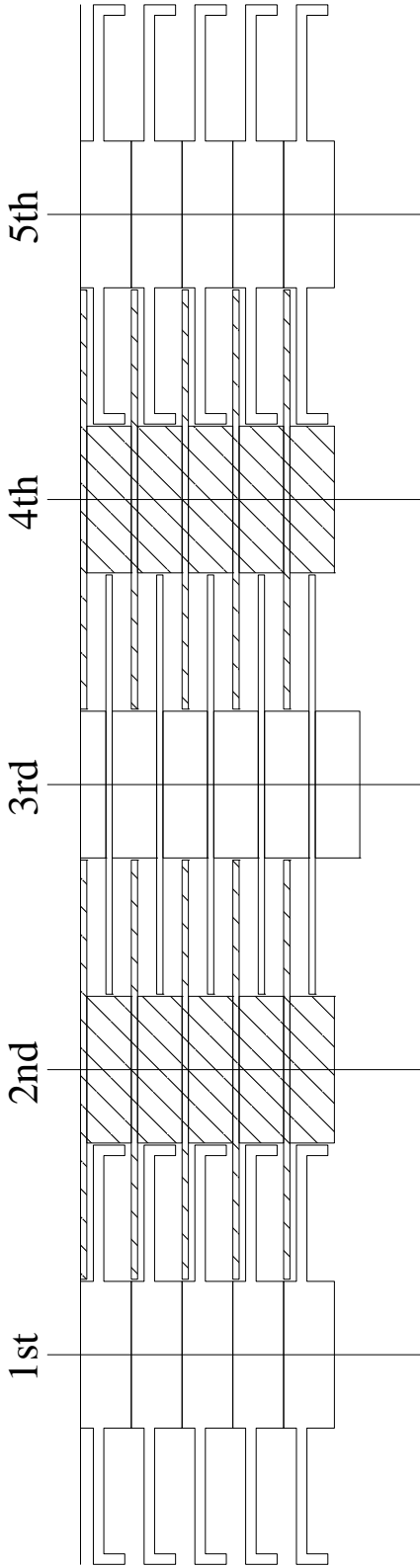

5mm (0.19") DISCREEN DISC SPACER BUILD UP ONLY
EXAMPLE - 4 SHAFT CONFIGURATION

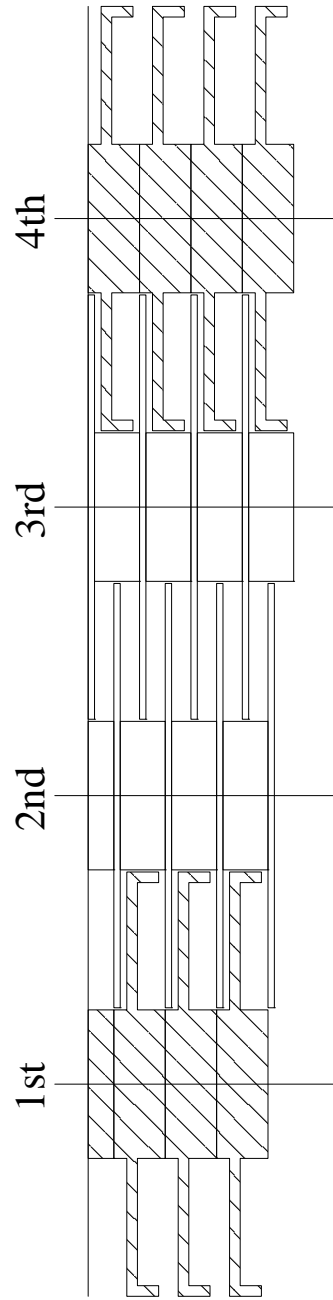

Build Up - 5mm (0.19'') Spacing

1M THROAT

SHAFT CONFIGURATION														
1st			2nd			3rd (Drive)			4th			5th		
MATL.	DRG.No.	QTY	MATL.	DRG.No.	QTY	MATL.	DRG.No.	QTY	MATL.	DRG.No.	QTY	MATL.	DRG.No.	QTY
SO	D000 2503	61	SO	D000 2500	61	SO	D000 3551	1	SO	D000 2500	61	SO	D000 2503	61
SR	L000 3502	1	SO	D000 3550	61	SO	D000 2500	61	SO	D000 3550	61	SR	L000 3502	1
			SO	D000 2500	1	SO	D000 3550	61	SO	D000 2500	1			
			SR	L000 3500	1	SO	D000 2500	1	SR	L000 3500	1			

Example - 5 shaft

For a 3 shaft machine - TAKE OUT (columns 3 & 4)

For a 7 shaft machine - ADD (columns 3 & 4) x 1

For a 9 shaft machine - ADD (columns 3 & 4) x 2

SHAFT CONFIGURATION											
1st			2nd			3rd (Drive)			4th		
MATL.	DRG.No.	QTY	MATL.	DRG.No.	QTY	MATL.	DRG.No.	QTY	MATL.	DRG.No.	QTY
SO	D000 3551	1	SO	D000 3551	1	SO	D000 2500	61	SO	D000 2503	61
SO	D000 2503	61	SO	D000 2500	61	SO	D000 3550	61	SR	L000 3502	1
SR	A02A 3503	1	SO	D000 3550	61	SO	D000 2500	1			
			SO	D000 2500	1	SR	L000 3500	1			

Example - 4 shaft

For a 6 shaft machine - ADD (columns 2 & 3) x 1

For a 8 shaft machine - ADD (columns 2 & 3) x 2

For a 10 shaft machine - ADD (columns 2 & 3) x 3

1.5M THROAT

SHAFT CONFIGURATION														
1st			2nd			3rd (Drive)			4th			5th		
MATL.	DRG.No.	QTY	MATL.	DRG.No.	QTY	MATL.	DRG.No.	QTY	MATL.	DRG.No.	QTY	MATL.	DRG.No.	QTY
SO	D000 2503	93	SO	D000 2500	93	SO	D000 3551	1	SO	D000 2500	93	SO	D000 2503	93
SR	A02A 3500	1	SO	D000 3550	93	SO	D000 2500	92	SO	D000 3550	93	SR	A02A 3500	1
			SO	D000 2500	1	SO	D000 3550	92	SO	D000 2500	1			
			SR	D000 3502	1	SO	D000 2500	1	SR	D000 3502	1			
						SR	L000 3501	1						

Example - 5 shaft

For a 3 shaft machine - TAKE OUT (columns 3 & 4)

For a 7 shaft machine - ADD (columns 3 & 4) x 1

For a 9 shaft machine - ADD (columns 3 & 4) x 2

SHAFT CONFIGURATION											
1st			2nd			3rd (Drive)			4th		
MATL.	DRG.No.	QTY	MATL.	DRG.No.	QTY	MATL.	DRG.No.	QTY	MATL.	DRG.No.	QTY
SO	D000 3551	1	SO	D000 3551	1	SO	D000 2500	93	SO	D000 2503	93
SO	D000 2503	92	SO	D000 2500	92	SO	D000 3550	93	SR	A02A 3500	1
SO	D000 3550	1	SO	D000 3550	92	SO	D000 2500	1			
			SO	D000 2500	1	SR	D000 3502	1			
			SR	L000 3501	1						

Example - 4 shaft

For a 6 shaft machine - ADD (columns 2 & 3) x 1

For a 8 shaft machine - ADD (columns 2 & 3) x 2

For a 10 shaft machine - ADD (columns 2 & 3) x 3

2M THROAT

SHAFT CONFIGURATION														
1st			2nd			3rd (Drive)			4th			5th		
MATL.	DRG.No.	QTY	MATL.	DRG.No.	QTY	MATL.	DRG.No.	QTY	MATL.	DRG.No.	QTY	MATL.	DRG.No.	QTY
SO	D000 2503	126	SO	D000 2500	126	SO	D000 3551	1	SO	D000 2500	126	SO	D000 2503	126
SR	L000 3502	1	SO	D000 3550	126	SO	D000 2500	126	SO	D000 3550	126	SR	L000 3502	1
			SO	D000 2500	1	SO	D000 3550	126	SO	D000 2500	1			
			SR	A02A 3502	1	SO	D000 2500	1	SR	A02A 3502	1			
						SR	A02A 3506	1						

Example - 5 shaft

For a 3 shaft machine - TAKE OUT (columns 3 & 4)

For a 7 shaft machine - ADD (columns 3 & 4) x 1

For a 9 shaft machine - ADD (columns 3 & 4) x 2

SHAFT CONFIGURATION											
1st			2nd			3rd (Drive)			4th		
MATL.	DRG.No.	QTY	MATL.	DRG.No.	QTY	MATL.	DRG.No.	QTY	MATL.	DRG.No.	QTY
SO	D000 3551	1	SO	D000 3551	1	SO	D000 2500	126	SO	D000 2503	126
SO	D000 2503	126	SO	D000 2500	126	SO	D000 3550	126	SR	L000 3502	1
SR	A02A 3500	1	SO	D000 3550	126	SO	D000 2500	1			
			SO	D000 2500	1	SR	A02A 3502	1			
			SR	A02A 3506	1						

Example - 4 shaft

For a 6 shaft machine - ADD (columns 2 & 3) x 1

For a 8 shaft machine - ADD (columns 2 & 3) x 2

For a 10 shaft machine - ADD (columns 2 & 3) x 3

Spacer/Disc Thickness Reference

MATL.	SPACER/DISC DRG. No.	THICKNESS (inch)
SO	D000 2500	0.11
SO	D000 2502	0.95
SO	D000 2503	0.63
SO	D000 3550	0.51
SO	D000 3551	0.31
SR	D000 3502	0.10
SR	D000 3503	0.19
SR	D000 3504	0.35
SR	L000 3500	0.30
SR	L000 3501	0.40
SR	L000 3502	0.55
SR	A02A 3500	0.22
SR	A02A 3501	0.31
SR	A02A 3502	0.44
SR	A02A 3503	0.09
SR	A02A 3504	0.14
SR	A02A 3505	0.03
SR	A02A 3506	3.17

Exploded Views

Discam Front

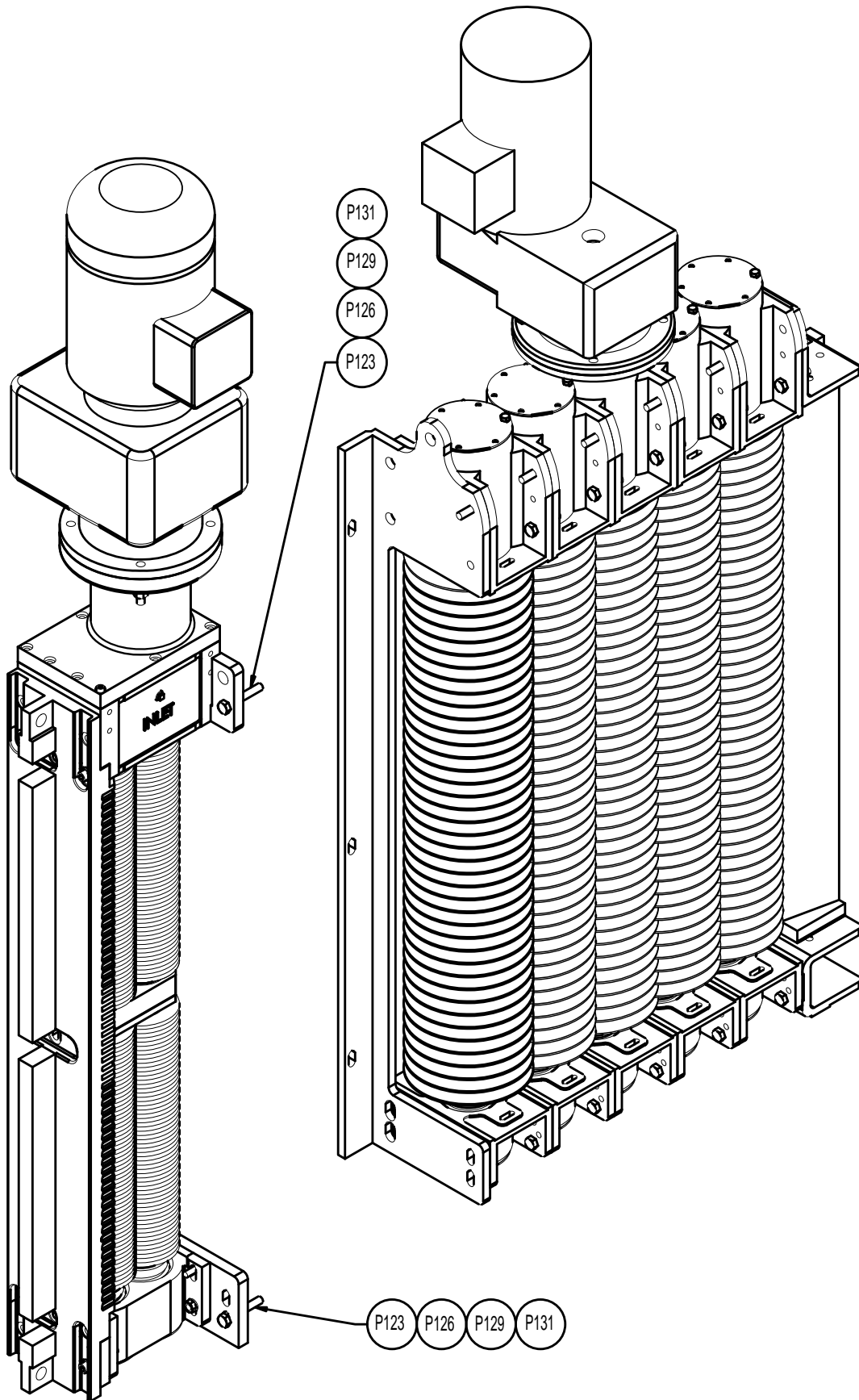

Exploded Views

Discam Back

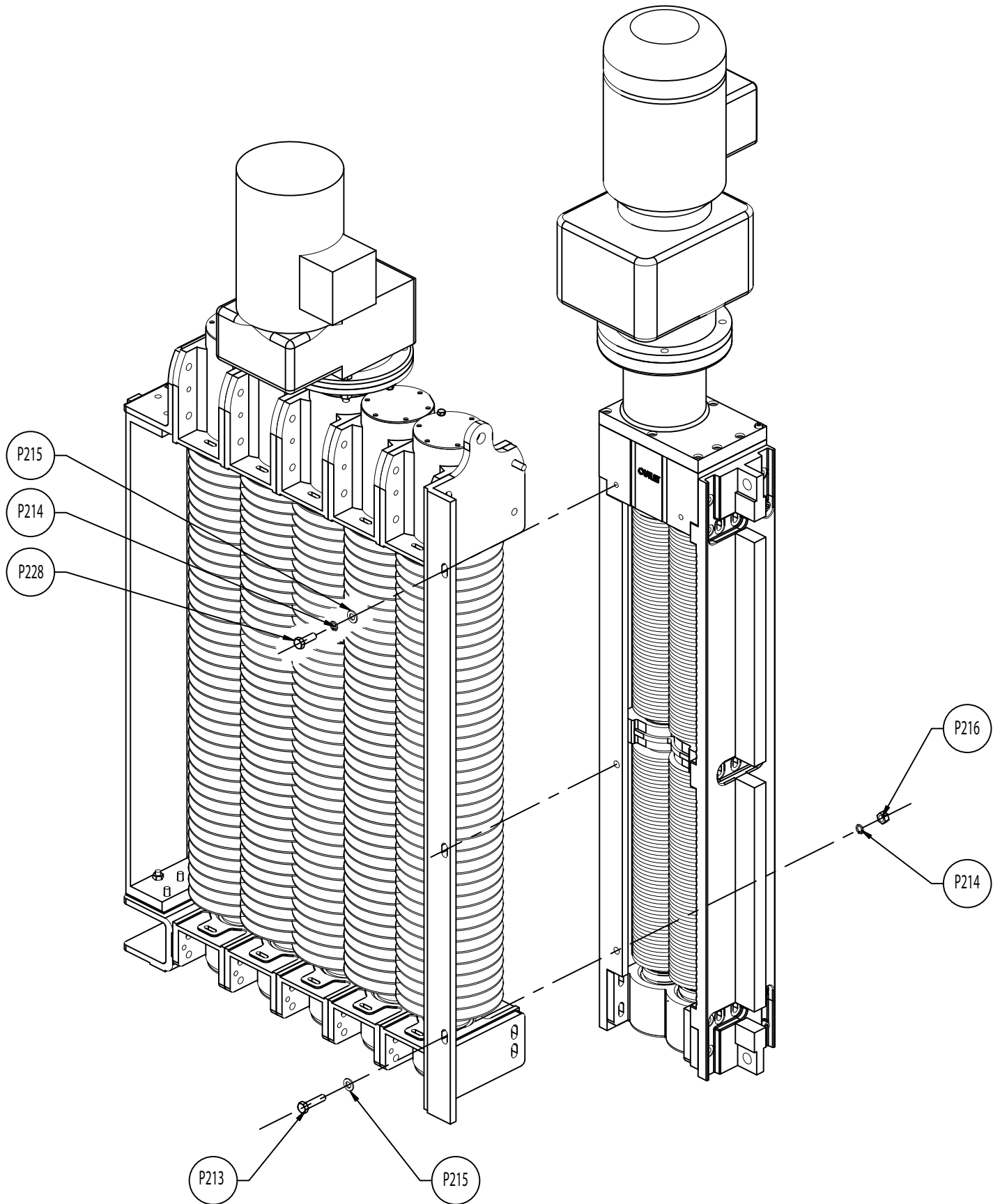

Exploded Views

Muncher - Full Machine

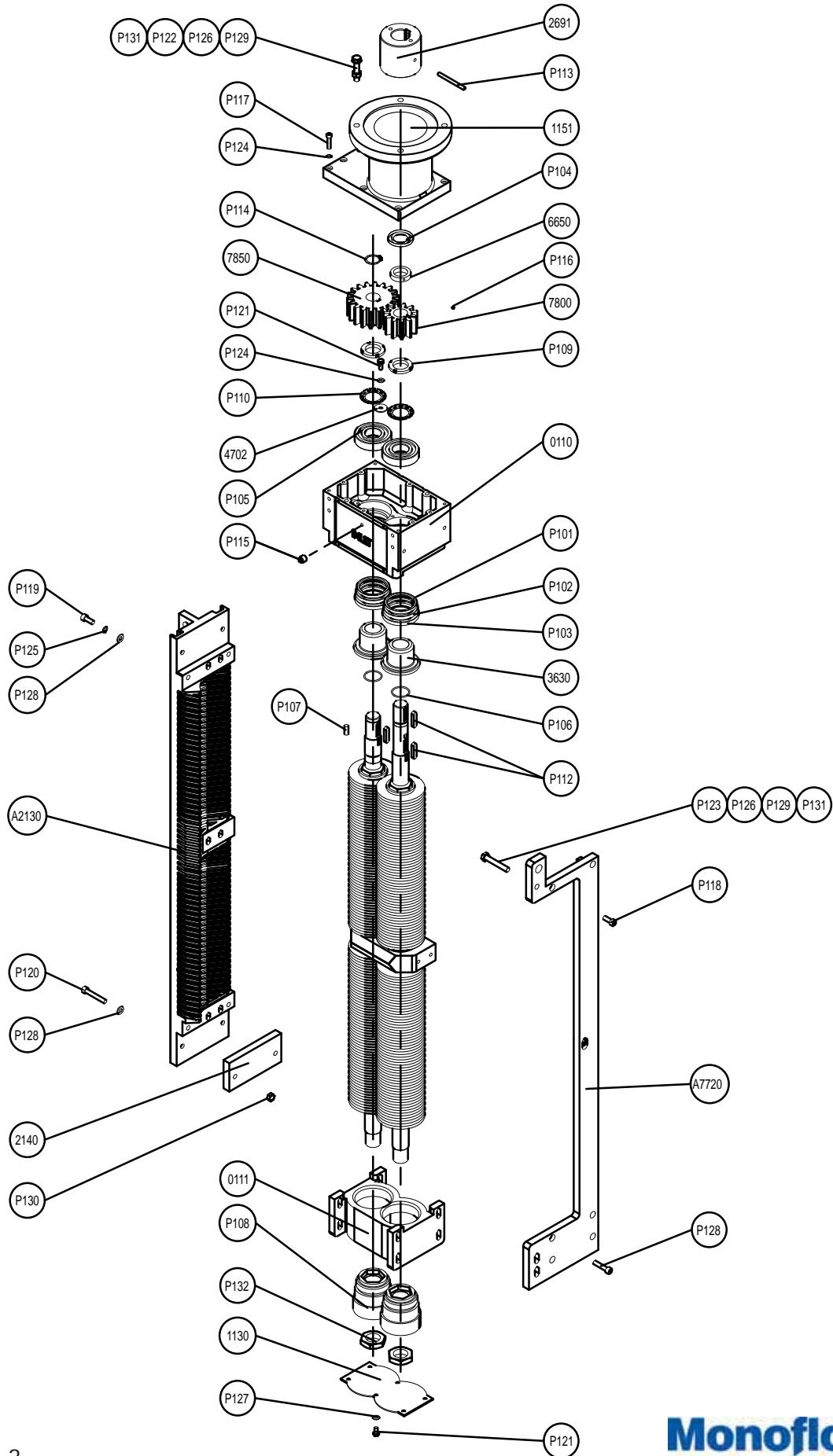

Exploded Views

Discreen - Full Machine

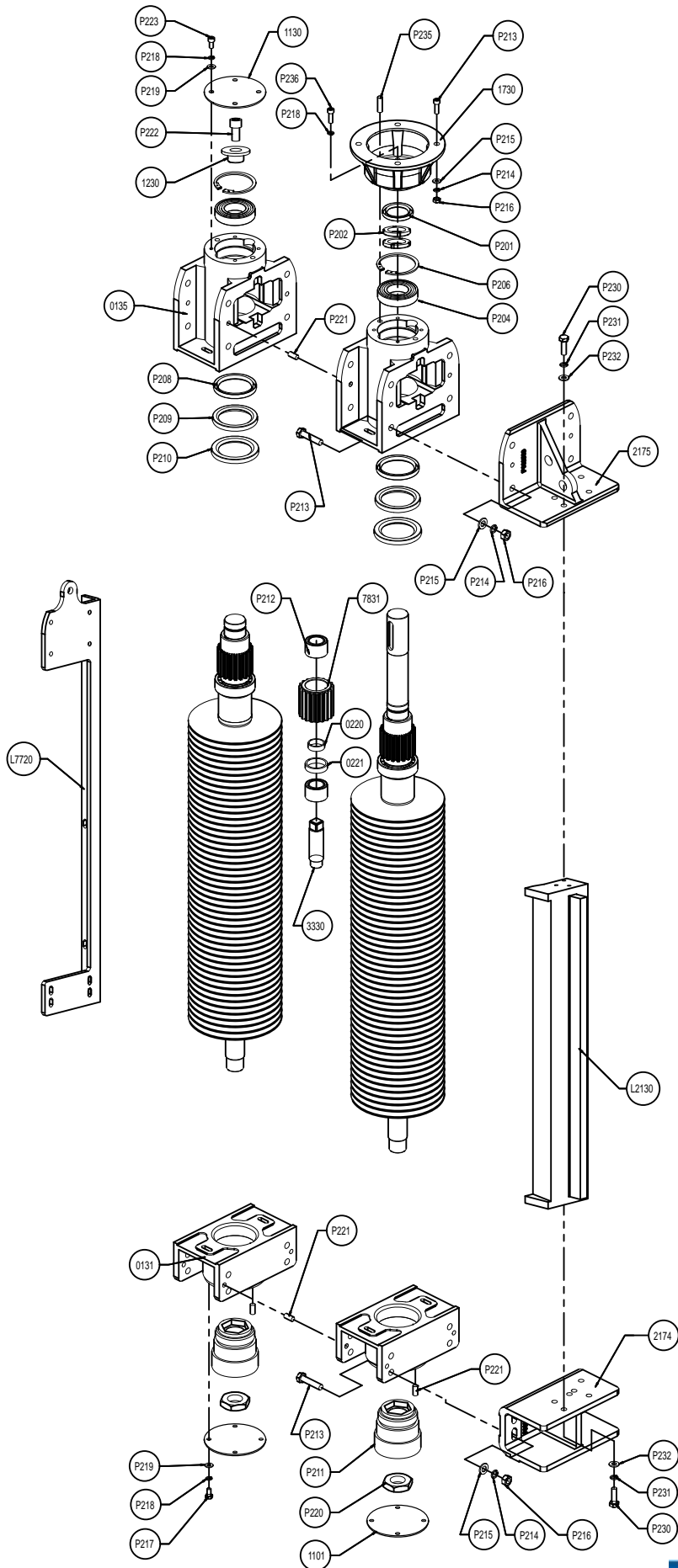

Exploded Views

Muncher - Shafts

Quantity & part number is dependent on model

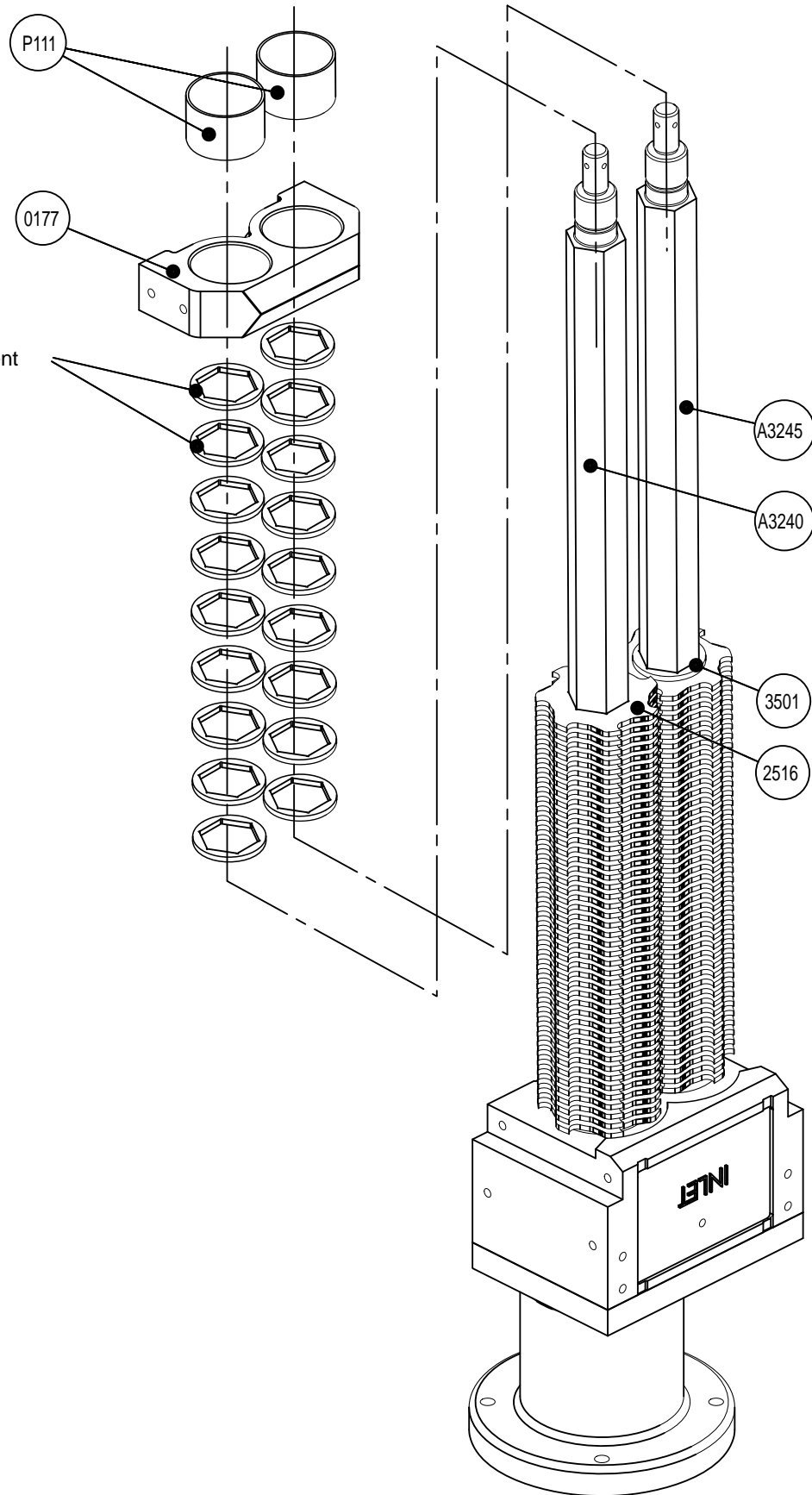

Exploded Views

Discreen - Shafts

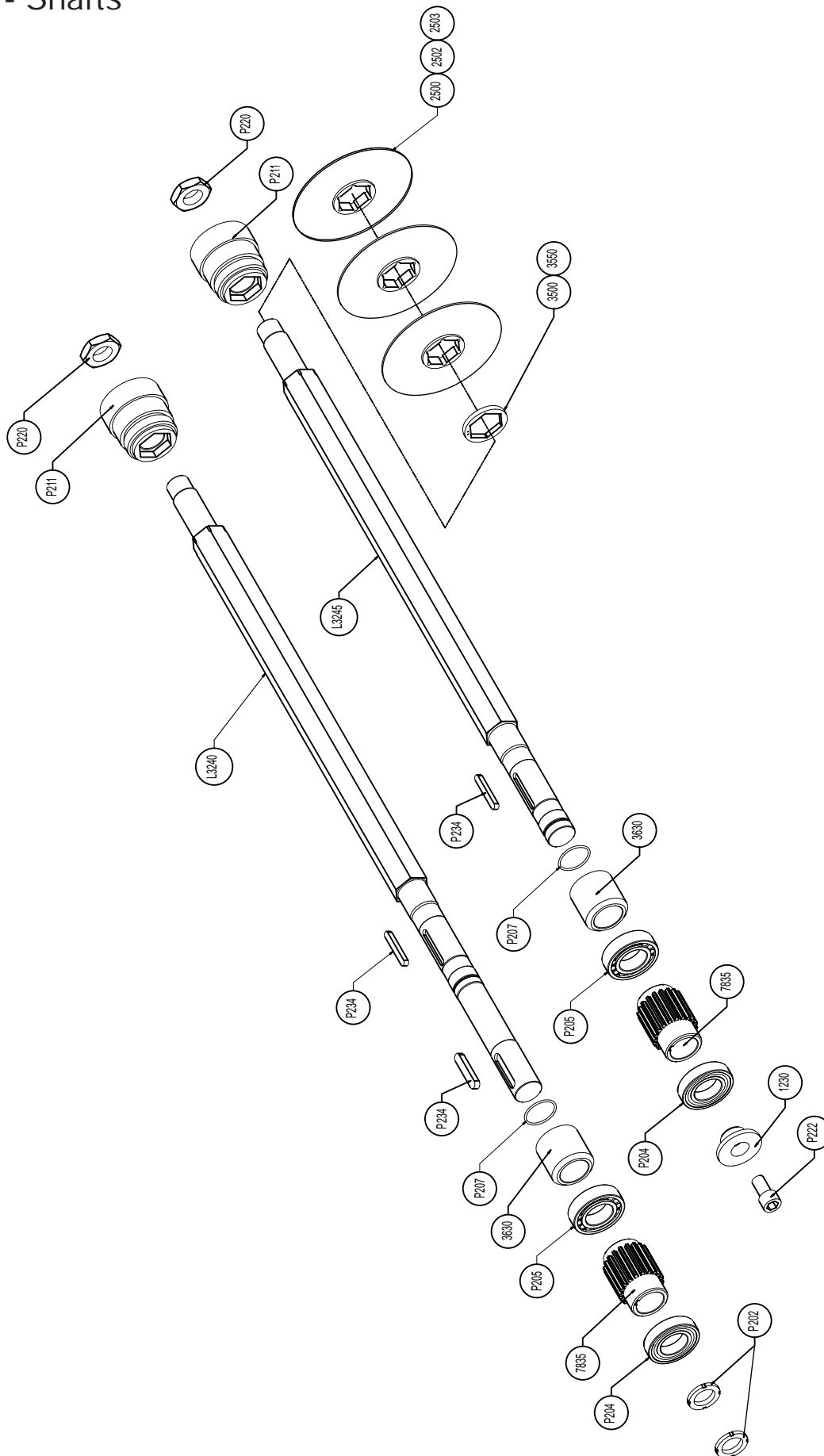

Sectional Views

Muncher

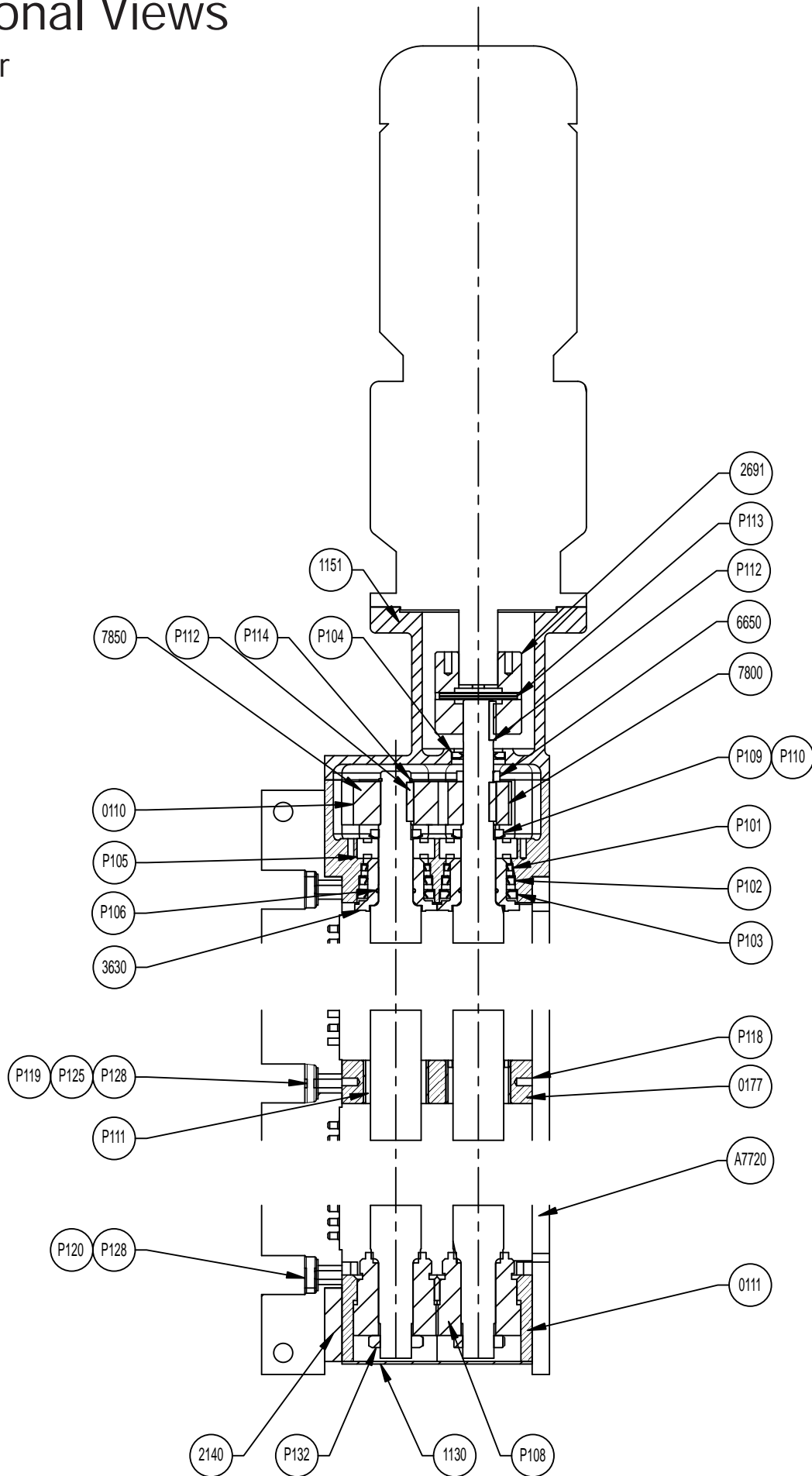

Sectional Views

Discreen

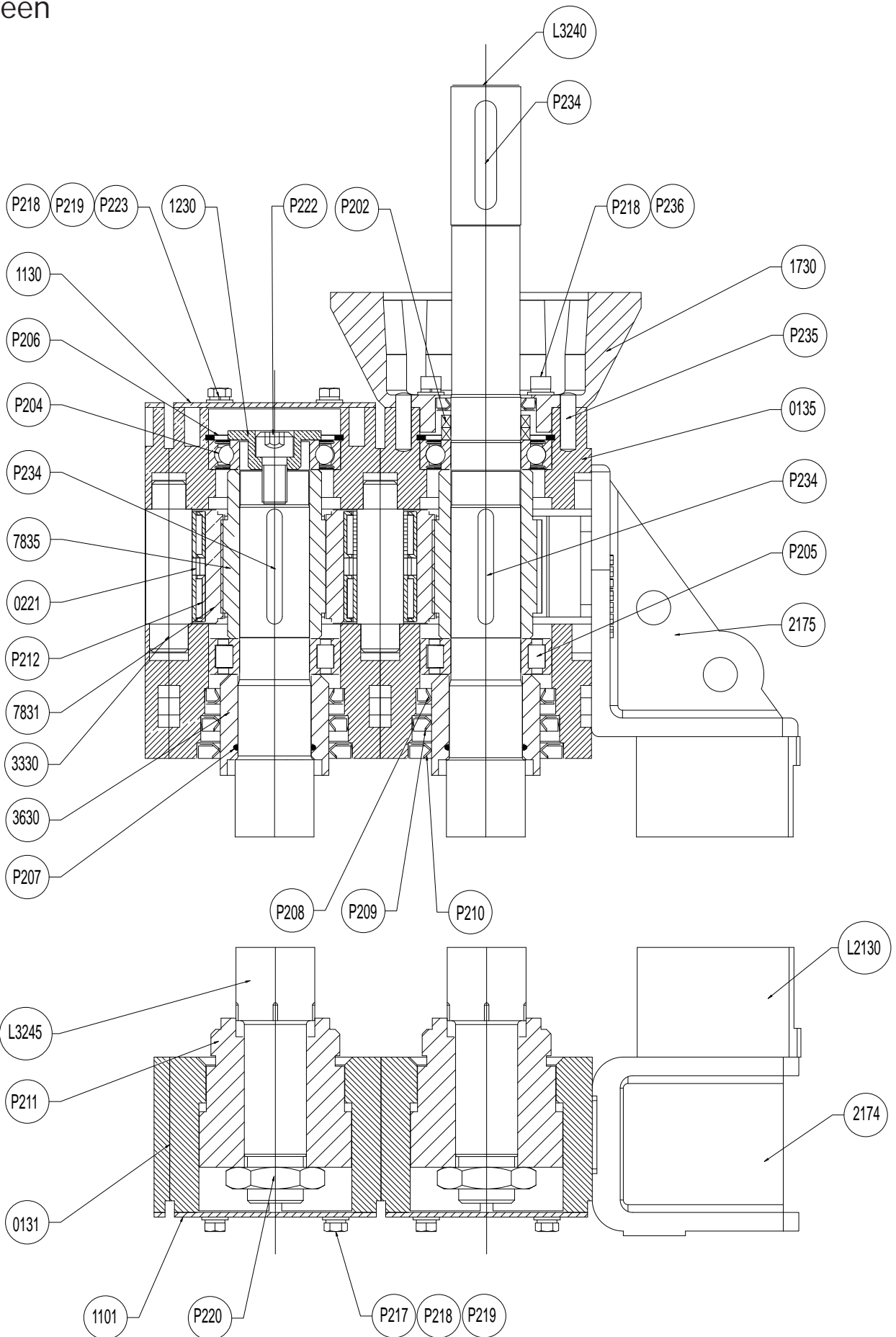

Parts List

Muncher

ITEM	DESCRIPTION
6650	ABUTMENT RING
7800	DRIVE GEAR 11 TOOTH
O110	MUNCHER TOP BRG HSG - DISCAM
1151	MUNCHER ADAPTOR STOOL - DISCAM
7850	DRIVEN GEAR 18 TOOTH
4702	BRG RETAINING WASHER
3630	TOP STACK COLLAR DISCAM
1130	BOTTOM COVER PLATE DISCAM
O111	MUNCHER BOTTOM BEARING HOUSING
A3240	1M DRIVE SHAFT DISCAM
A3245	1M DRIVEN SHAFT DISCAM
O177	MUNCHER MID HOUSING - DISCAM
A2130	SIDE RAIL MUNCHER - DISCAM
2140	SIDE RAIL PACKER PLATE DISCAM
A7720	MUNCHER INBOARD SIDERAIL - 1M
2516	ETOS CUTTER 8MM THICK 5 TOOTH
3501	SPACER 8MM THICK
2691	1 PIECE MUNCHER COUPLING
P101	ROTARY SHAFT LIPSEAL 65x80x8
P102	ROTARY SHAFT LIPSEAL 65x85x10
P103	ROTARY SHAFT LIPSEAL 65x90x10
P104	ROTARY SHAFT LIPSEAL 35x62x7
P105	BALL BRG 40x90x23
P106	TORL SEAL RING 0395-30 BK NITR
P107	ROLL PIN 3 DIA x 20 LONG
P108	DISCREEN BOTTOM MECH SEAL
P109	SKEFKO LOCKNUT KM8-M40x1.5
P110	SKEFKO LOCK WASHER MB8 (M40)
P112	RECT PAR KEY 10x8x45
P113	ROLL PIN DIA 8x90 LG
P112	RECT PAR KEY 10x8x45
P114	CIRCLIP-EXT. HEAVY DUTY 35MM
P115	HEX.C/SUNK PLUG 3/8"BSP
P116	HEX SOC SETSCREW M6x6
P117	ST.STL.SOC.CAP SCREW M8x35
P118	ST.STL.SOC.CAP SCREW M10x25
P119	ST.STL.SOC.CAP SCREW M10x45
P120	HT.STL.SOC.CAP SCREW M10x65
P121	ST.STL.HEX.HD SCREW M8x16
P122	M12x60 HEX.HD SCREW ST STL
P123	STL.HEX.HD.SCREW M12x80
P124	M8 S/ST SGL SPRING WASHER
P125	ST STL SPRING WASHER M10
P126	ST STL SNGL.COIL SPR.WASHR M12
P127	ST STL PLAIN WASHER M8
P128	ST STL BRIGHT WASHER M10
P129	ST STL BRIGHT WASHER M12
P130	ST STL HEX NUT M10
P131	ST STL HEX NUT M12
P132	M36x2MM PITCH HEX. THIN NUT
P133	10x25 PAR DOWEL PIN

Parts List

Discreen

ITEM	DESCRIPTION	ITEM	DESCRIPTION
1230	DRIVEN SHAFT END CAP DISCAM	P201	ROTARY SHAFT LIPSEAL 40x60x8
1130	TOP COVER PLATE DISCAM	P202	SKEFKO LOCKNUT KM9-M45x1.5
7835	DISCREEN DRIVE GEAR	P203	INT. CIRCLIP 100MM x 3 THK
3630	TOP STACK COLLAR	P204	SGL ROW BALL BRG 45x100x25
O135	TOP HOUSING DISCREEN - DISCAM	P205	NUP2209 ROLLER BRG 45x85x23
1101	BOTTOM COVER PLATE	P206	RETAINING RING VHM-85. DIA 85
O131	BOTTOM HOUSING	P207	TORL SEAL RING SPCL. BK NITR
O220	IDLER GEAR BEARING SPACER	P208	ROTARY SHAFT LIPSEAL 70x90x10
O221	IDLER GEAR BEARING SPACER	P209	ROTARY SHAFT LIPSEAL 70x95x10
3330	IDLER SHAFT	P210	ROTARY SHAFT LIPSEAL 70x100x10
7831	IDLER GEAR	P211	DISCREEN BOTTOM MECH SEAL
L7720	DISCREEN INBOARD SIDERAIL - 1M	P212	NA6906 ROLLER BRG 30x47x30
2175	SIDERAIL MTG BRKT TOP	P213	ST STL HEX HD SCREW M12x50
2130	PACKING PLATE DISCAM	P214	ST STL SNGL COIL SPR WASHER M12
L2130	SIDERAIL 1000. DISCREEN DISCAM	P215	ST STL BRIGHT WASHER M12 (316)
2174	SIDERAIL MTG BRKT BOTTOM	P216	ST STL HEX NUT M12
L3240	1M DRIVE SHAFT DISCAM	P217	ST STL HEX HD SCREW M8x16
L3245	1M DRIVEN SHAFT DISCAM	P218	M8 S/ST SGL SPRING WASHER
2502	DISC AND SPACER. DISCAM	P219	ST STL PLAIN WASHER M8
2500	DISCREEN DISC (9MM & 5MM M/C)	P220	M36x2MM PITCH HEX. THIN NUT
3550	DISC SPACER 13.11 THK	P221	DOWEL PIN GD1 10x25LG
3501	DISC SPACER 8.11 THK	P222	HT STL SOC CAP SCREW M16x30
3503	SPACER SHIM 2.45MM THK	P223	ST STL HEX HD SCREW M8x25
3504	SPACER SHIM 3.57MM THK	P224	1/2" BSP WINDOW NUT (BRASS)
3504	DISC SPACER 9.11 THK	P225	1/2" NPT OIL LEVEL SENSOR
1730	ADAPTOR STOOL. DISCREEN DISCAM	P226	SOCKET PRESSURE PLUG 1/2" BSP
9955	LIFTING GEAR - 5 SHAFT DISCAM	P227	NAME PLATE DISCAM
		P228	M12x40 SOC HD CAP SCREW ST STL
		P229	ST STL HEX HD SCREW M12x35 LG
		P230	ST STL HEX HD SCREW M10x55
		P231	ST STL SPRING WASHER M10
		P232	ST STL BRIGHT WASHER M10
		P233	ST STL HEX NUT M10
		P234	RECT PAR KEY FORM B 10x8x66
		P235	DOWEL PIN GD1 8x30 LG
		P236	HT 12.9 SOC CAP SCREW M8x35
		P237	M20x32 COLLAR EYEBOLT
		P238	STEEL BRIGHT WASHER M20
		P239	SNGL COIL SPR WASHER M20
		P240	STEEL HEX NUT M20

Loctite Assembly - Discam Build Instruction

The following requirements should be observed when building Discams. They apply to both the muncher and discreen:

The top bearings on all shafts should be fitted using Loctite 641 medium strength retainer. This will reduce fretting of the shaft bearing surface whilst still allowing the bearing to be removed with conventional tools. The bearing should be pushed hard against either the locknuts (discreen drive) or stub washer (discreen driven) or lock washer and nut (muncher) as soon as possible in the assembly process. All surfaces should be clean and grease free.

Where the tolerance build up dictates that it is necessary to chamfer the corners of the gear drive keys the chamfers should be as small as possible to allow fitting of the gear. Over large chamfers reduce the key/keyway contact area and induce higher stresses on the key and the drive gear keyway.

The cavities above the three upper lipseals should also be packed with grease for the same reasons.

The top and bottom cover plates, drive stool and side rail brackets should be fitted using Loctite 5910 sealant (as shown).

Loctite Assembly

Muncher

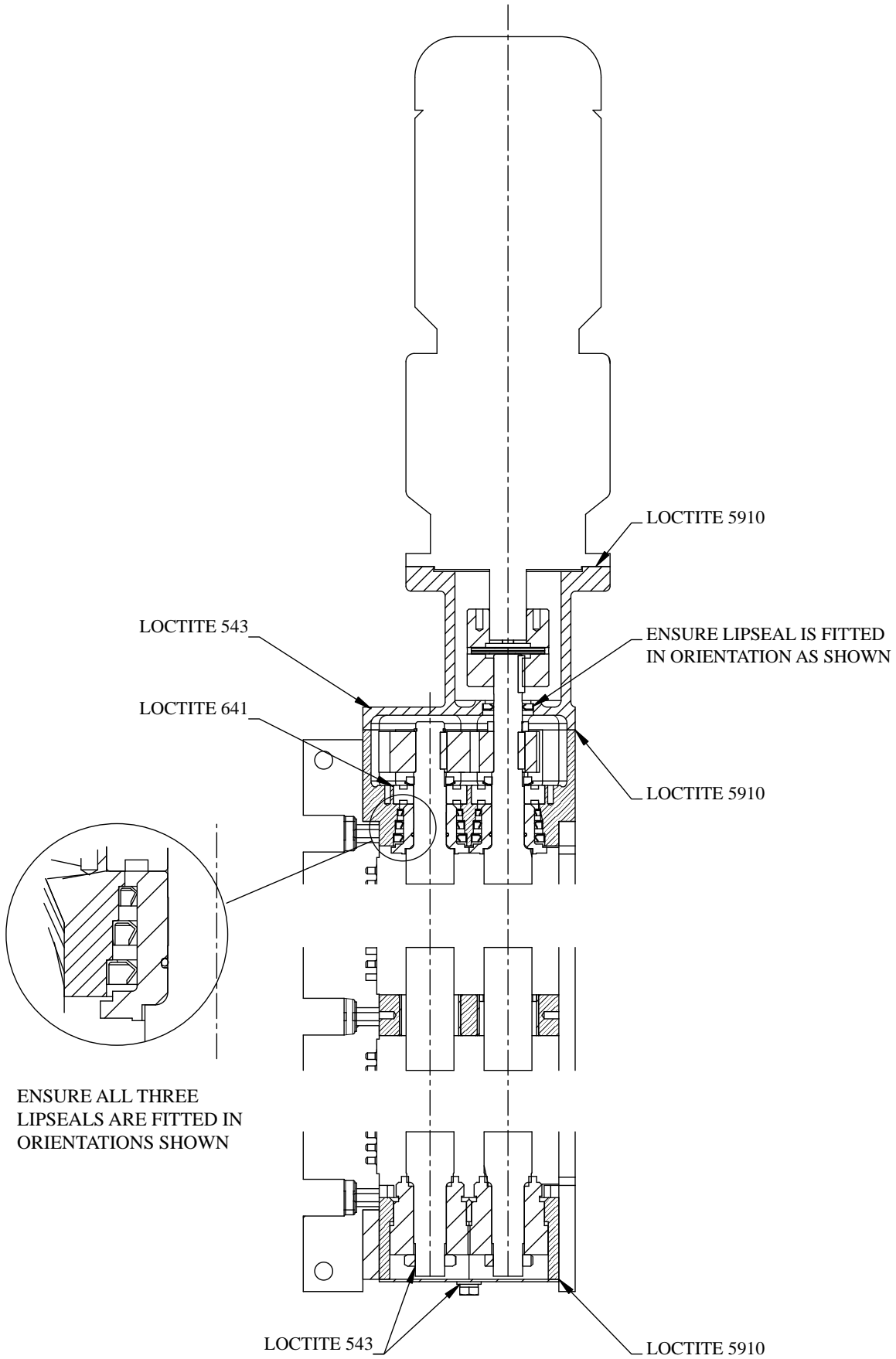

Loctite Assembly

Discreen

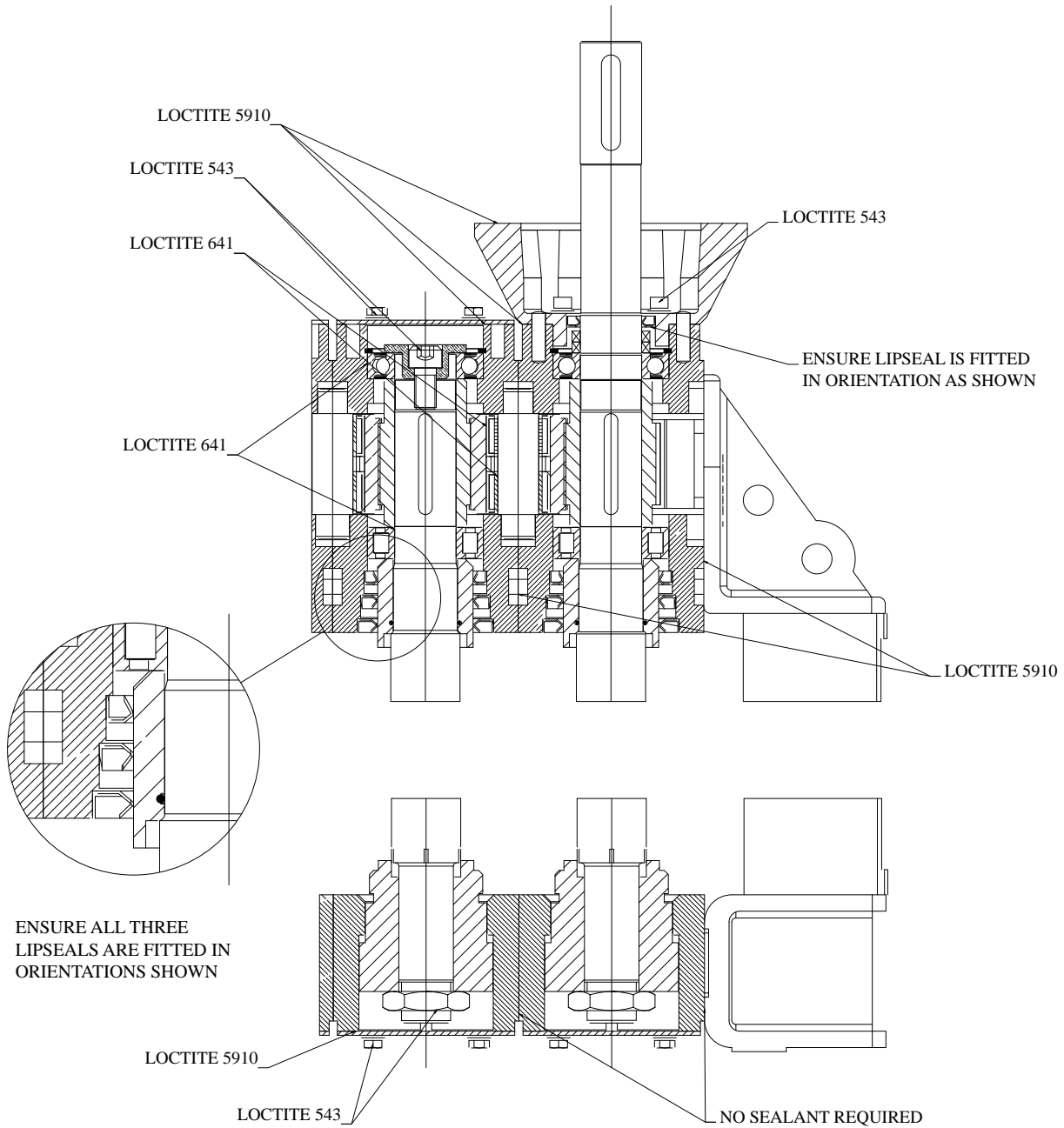

Oil Filled Machine Hardware Details

Discreen

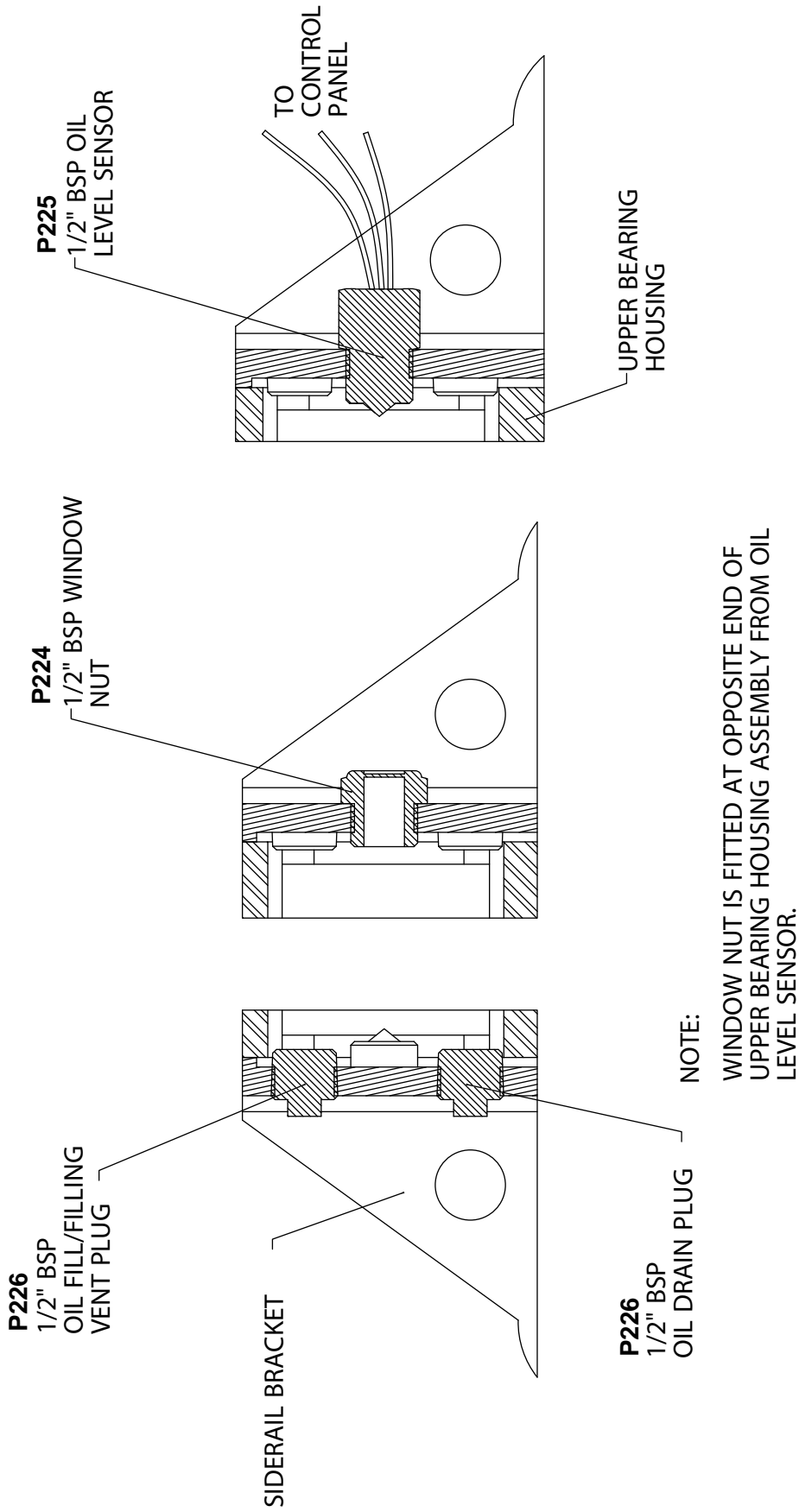

Torque Tightening

Discreen, all throat sizes

RE-ASSEMBLY

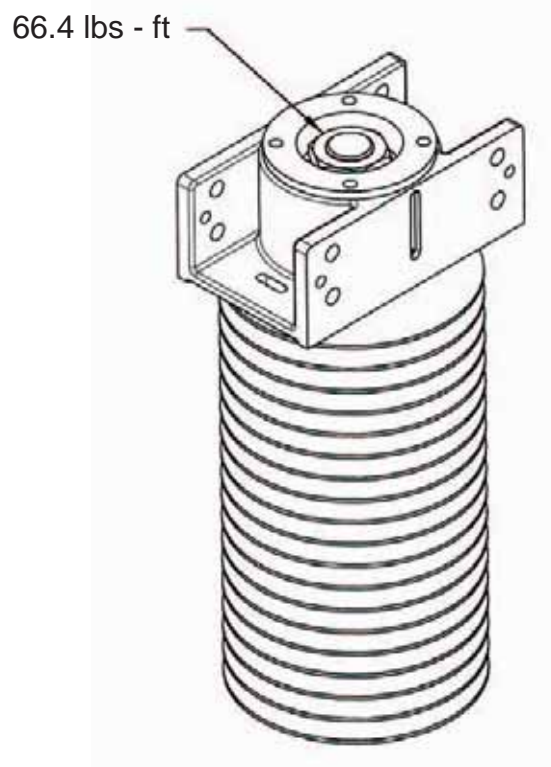
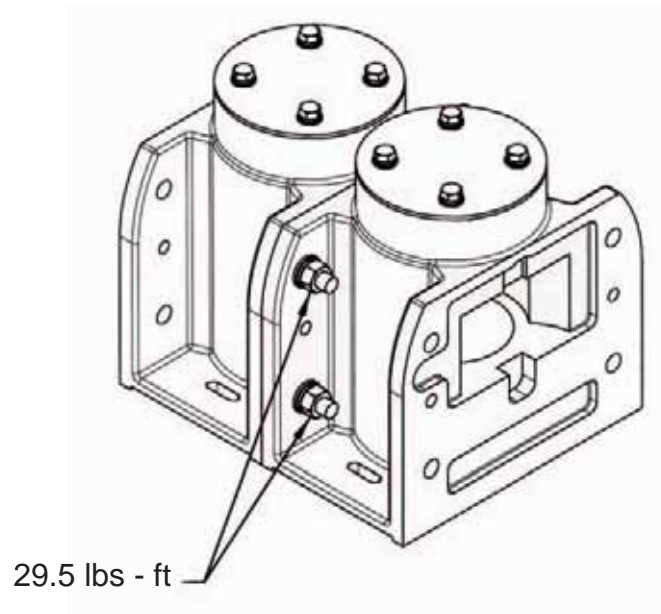

Lifting Arrangement

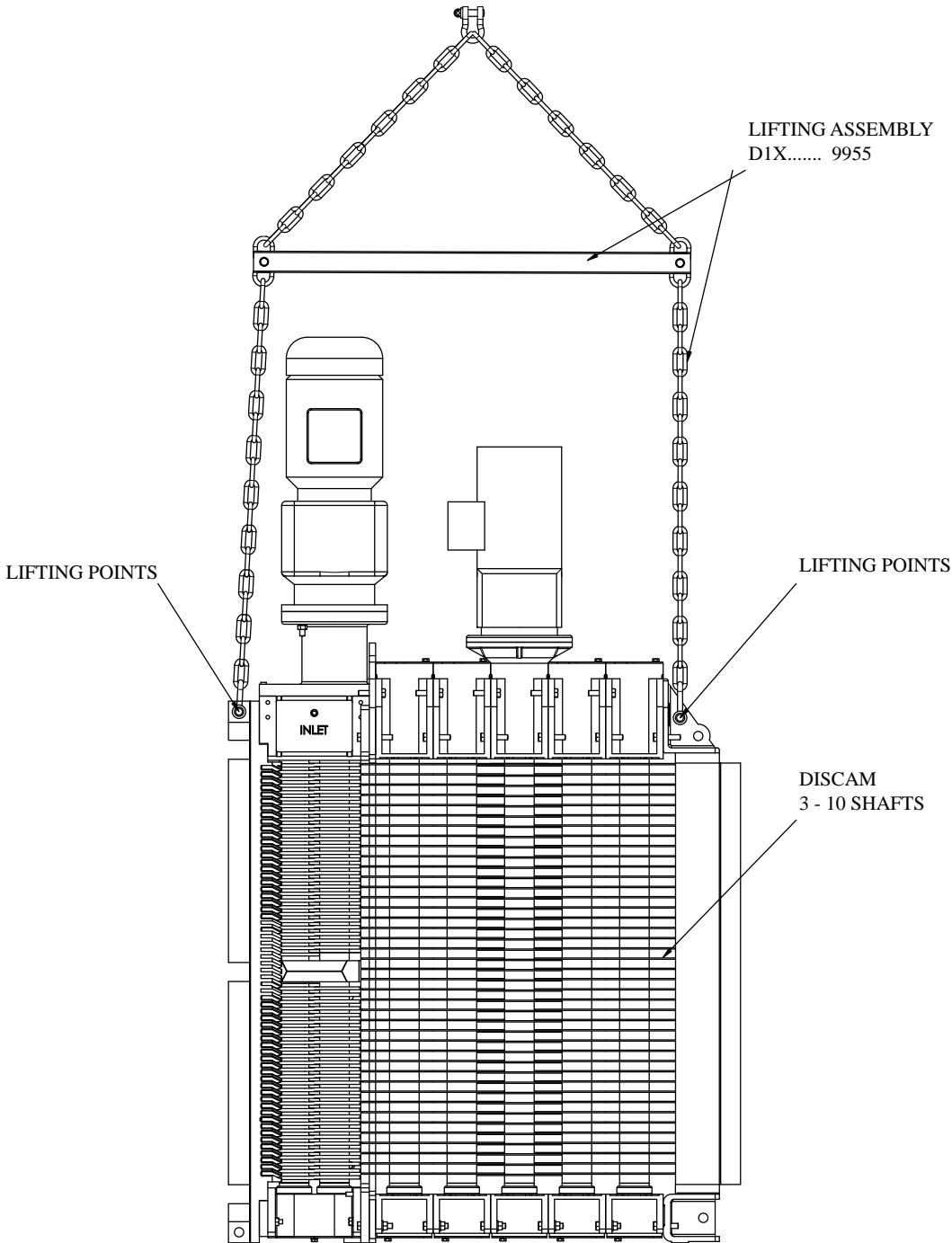

DISCAM No. OF SHAFTS	LIFTING ASSEMBLY DRG. No.
3	D1X03 9955
4	D1X04 9955
5	D1X05 9955
6	D1X06 9955
7	D1X07 9955
8	D1X08 9955
9	D1X09 9955
10	D1X10 9955

WEIGHTS(lbs)		SHAFTS							
		3	4	5	6	7	8	9	10
THROAT	40"	1958	2200	2442	2706	2948	3212	3454	3718
	60"	2398	2706	3014	3322	3630	3938	4246	4554
	80"	2926	3300	3674	4026	4400	4774	5126	5500

Note: Weight specified include IP55 geared motors. For IP68 drives, add 35 lbs.

UK and Europe

Mono Pumps Ltd, Martin Street, Audenshaw
Manchester, M34 5JA, England
T. +44 (0)161 339 9000
E. info@mono-pumps.com

Americas

Monoflo Inc., 9700 West Gulf Bank
Houston, Texas 77040, USA
T. +1 281 272 7700
E. inquire@monoflo.com

Monoflo SA

Ing. Huergo 2239 - B1842GGW
Monte Grande
Buenos Aires
Argentina
T. +54 4296 8997
F. +54 4284 0323
E. inquire@monoflo.com

Australasia

Mono Pumps (Australia) Pty Ltd
Mono House, 338-348 Lower Dandenong Road
Mordialloc, Victoria 3195, Australia
T. +61 (0)3 9580 5211
E. ozsales@mono-pumps.com

Mono Pumps (New Zealand) Ltd
PO Box 71-021, Fremlin Place, Avondale
Auckland 7, New Zealand
T. +64 (0)9 829 0333
E. info@mono-pumps.co.nz

Asia

Mono Pumps Ltd, No. 500 YaGang Road
Lujia Village, Malu, Jiading District
Shanghai 201801, P.R. China
T. +86 (0)21 5915 7168
E. monoshanghai@nov.com



One Company, Unlimited Solutions